

**Stanislav Ivanov**

**HOTEL REVENUE MANAGEMENT**  
*FROM THEORY TO PRACTICE*



**Stanislav Ivanov**

**HOTEL REVENUE MANAGEMENT**  
*FROM THEORY TO PRACTICE*



2014

First published 2014

by Zangador Ltd.

Varna, Bulgaria; tel: +359 52 330 964; email: office@zangador.eu



This work is licensed under the Creative Commons Attribution-NonCommercial-NoDerivatives 4.0 International License. To view a copy of this license, visit <http://creativecommons.org/licenses/by-nc-nd/4.0/>.

ISBN: 978-954-92786-3-7

Reference:

Ivanov, Stanislav (2014). *Hotel Revenue Management: From Theory to Practice*. Varna: Zangador

*To Maya and Hristo*

## **PREFACE**

This research monograph aims at developing an integrative framework of hotel revenue management. It elaborates the fundamental theoretical concepts in the field of hotel revenue management like the revenue management system, process, metrics, analysis, forecasting, segmentation and profiling, and ethical issues. Special attention is paid on the pricing and non-pricing revenue management tools used by hoteliers to maximise their revenues and gross operating profit. The monograph investigates the revenue management practices of accommodation establishments in Bulgaria and provides recommendations for their improvement. The book is suitable for undergraduate and graduate students in tourism, hospitality, hotel management, services studies programmes, and researchers interested in revenue/yield management. The book may also be used by hotel general managers, marketing managers, revenue managers and other practitioners looking for ways to improve their knowledge in the field.

## ACKNOWLEDGEMENTS

The author would like to thank the following people who made this monograph happen:

- Prof. Steven F. Illum, Missouri State University (USA), and Prof. Metin Kozak, Dokuz Eylul University (Turkey), for their constructive reviews of the manuscript.
- Vladyslav Ralko from the MBA programme at International University College (Bulgaria) who helped with the primary data collection.
- All hoteliers, manager and owners of accommodation establishments in Bulgaria who devoted their precious time in the empirical research.
- The participants in the *Hotel Revenue Management* courses of the author who have shared their views and practical experience in the field.
- Finally, I would like to thank my family who had to accept my long hours in front of the computer.

# HOTEL REVENUE MANAGEMENT: *FROM THEORY TO PRACTICE*

## TABLE OF CONTENTS:

	PAGE
<b>Chapter 1.</b> Introduction to hotel revenue management	7
<b>Chapter 2.</b> Economic fundamentals of hotel revenue management	13
<b>Chapter 3.</b> Hotel revenue management system	22
<b>Chapter 4.</b> Hotel revenue management process	34
<b>Chapter 5.</b> Hotel revenue management metrics	43
<b>Chapter 6.</b> Market segmentation, profiling and targeting	56
<b>Chapter 7.</b> Information provision for the revenue management process	66
<b>Chapter 8.</b> Revenue management analysis	70
<b>Chapter 9.</b> Revenue management forecasting	79
<b>Chapter 10.</b> Value creation	87
<b>Chapter 11.</b> Pricing hotel revenue management tools	98
<b>Chapter 12.</b> Non-pricing hotel revenue management tools	114
<b>Chapter 13.</b> Combined hotel revenue management tools	135
<b>Chapter 14.</b> Managing revenues in various hotel revenue management centres	149
<b>Chapter 15.</b> Hotel revenue management, ethics and relationship marketing	158
<b>Chapter 16.</b> Revenue management practices of accommodation establishments in Bulgaria	163
<i>Concluding thoughts</i>	187
<i>References</i>	188

# Chapter 1

## INTRODUCTION TO HOTEL REVENUE MANAGEMENT

Revenue management, also known as yield management, is an essential instrument for matching supply and demand by dividing customers into different segments based on their purchase intentions and allocating capacity to the different segments in a way that maximizes a particular firm's revenues (El Haddad, Roper & Jones, 2008). Kimes (1989) and Kimes & Wirtz (2003) define revenue management as the application of information systems and pricing strategies to allocate the right capacity to the right customer at the right price at the right time. This puts revenue management practice into the realm of marketing management where it plays a key role in demand creation (Cross, Higbie & Cross, 2009) and managing consumer behaviour (Anderson & Xie, 2010). Revenue management theory has also benefited strongly not only from marketing management research, but more profoundly from operations (e.g. Talluri & van Ryzin, 2005) and pricing research (Shy, 2008).

Initially developed by the airline industry after the deregulation process in the 1970s, revenue management has expanded to its current state as a common business practice in a wide range of industries. It is profitably applied by airlines, hotels, restaurants, golf courses, shopping malls, telephone operators, conference centres and other companies. This has triggered significant theoretical research in revenue management fundamentals and its application in various industries (Chiang, Chen & Xu, 2007; Cross, 1997; Ng, 2009a; Phillips, 2005; Talluri & van Ryzin, 2005), including tourism and hospitality (Avinal, 2006; Hayes & Miller, 2011; Ingold, McMahon-Beattie & Yeoman, 2001; Ivanov & Zhechev, 2012; Kimes, 2003; Lee-Ross & Johns, 1997; Legohérel, Poutier & Fyall, 2013a; Mauri, 2012; Tranter, Stuart-Hill & Parker, 2008; Yeoman & McMahon-Beattie, 2004, 2011). Moreover, the importance of revenue management as a research field has been recognised by the launch of two academic journals dedicated to the theory and practice of revenue management: *Journal of Revenue and Pricing Management* (published since 2002 by Palgrave MacMillan) and



the *International Journal of Revenue Management* (published since 2007 by Inderscience Publishers).

While there are general revenue management principles easily applied across different industries, each industry has also specific characteristics that determine the practical aspects of revenue management application in companies that work in it. What is a successful strategy for the airlines, for example, is not always a working solution for the hotel or restaurant. That's why this book concentrates on revenue management as applied by the hotel industry. Its goal is to identify and critically evaluate the revenue management principles, practices and techniques applied by hotels and other accommodation establishments. It develops the theoretical framework of hotel revenue management as a concept, analyses the various pricing and non-pricing revenue management tools in the hoteliers' arsenal and delves into contemporary issues related to the concept – ethics, human resources, relationship marketing. Finally, the book investigates the revenue management practices of accommodation establishments in Bulgaria, evaluates their effectiveness and provides recommendations for their improvement. For the sake of simplicity and to avoid repetition throughout the book the terms 'hotel', 'property' and 'accommodation establishment' are used interchangeably, although the author acknowledges the differences in their meaning.

Building on Kimes (1989) and Kimes & Wirtz (2003) we could define hotel revenue management as *the constellation of tools and actions dedicated toward the achievement of an optimal level of the hotel's net revenues and gross operating profit by offering the right product to the right customers via the right distribution channel at the right time at the right price with the right communication*. This long definition incorporates several key points:

- *Optimal level of hotel's net revenues and the gross operating profit*

The net revenues of the hotel include the sales revenues after taxes and commissions. The gross operating profit equals the net revenues minus the costs for serving the customers – the costs of goods sold, marketing, administrative, human resource expenses (Dopson & Hayes (2009). The keyword is 'optimal' level. Maximising the net revenues does not necessarily mean that the gross operating profit would be at its potential maximum level. For example, it may turn out that attracting additional customers to the hotel would be too costly to serve so that the gross operating profit

would be actually decreased. Furthermore, when companies work at full capacity the attention service employees could pay to every single customer is decreased which is a basis for operational mistakes, lack of personalised services, queues and other consequences that would have negative impact on customers' satisfaction and might even be used as grounds for complaints, the settlement of which would diminish the gross operating profit of the hotel. On the other hand, the increase in the gross operating profit might be a result of cost-cutting strategy, which, although sometimes is necessary and inevitable, often leads to service quality deterioration, dissatisfaction and future loss of customers and revenues. Therefore the goal of revenue management should not be maximising the revenues of the hotel at all costs, but achieving the highest revenues and gross operating profit *simultaneously*. The various revenue management metrics used in analysis and goal-setting are discussed in Chapter 5.

- *Right customer*

Not all customers are equally profitable for the hotel. Some of them are too costly to serve, i.e. they may have too high requirements which the hotel could not easily and profitably meet, while others are willing to pay too low prices which could hardly cover the hotel's expenses. The 'right' customer is a debatable concept from a marketing point of view but could be associated with the target market segment which has been identified by the hotel's marketing manager and whose requirements are taken into consideration when preparing the product of the hotel. The concept of the 'right' customer calls for the hotel to use various marketing techniques in order to attract the customers which it could properly and profitably serve and deny accommodation for the rest. Hotels, for example, put minimum stay requirements during specific busy periods (e.g. during fairs, exhibitions, world championships) so that they dissuade transit one-night stays in favour of more profitable longer stay customers. Market segmentation, profiling and targeting are discussed in Chapter 6, while ethical issues arising from the application of various revenue management techniques are discussed in Chapter 15.

- *Right product*

The right product is determined by both the customers and the hoteliers. It is the product that *a)* delivers value to the 'right' customers by satisfying their needs, wants, requirements, *b)* reflects the customer's willingness to pay, and *c)* is profitable for the

hotelier. It is useless to offer services and amenities in the hotel that do not fit the requirements of the target market segment, or offer services/amenities which these customers could not afford to buy or the hotel cannot provide profitably. The concept of value creation for the customer is addressed in details in Chapter 10.

- *Right distribution channel*

The hotel can sell its product via various distribution channels. It could sell directly to the customers or via travel agencies [classical brick-and-mortar tour operators and travel agents, or online travel agencies (OTAs)], global distribution systems (GDSs), online reservation systems, etc. (Ivanov & Zhechev, 2011). Each distribution channel provides access to different customers and requires different costs to sustain. Therefore, from the perspective of the revenue management's goal, the 'right' distribution channel is the channel that provides access to the 'right' customer and is cost effective to sustain. Distribution channel management is discussed in Chapter 13.

- *Right price*

The price is one of the most important instruments in the arsenal of revenue management tools because it is directly linked with the level of the revenues. By changing the level of prices over time, the ratio between different prices for various market segments (the so called "price structure") and the conditions applicable for each price level the hotel can attract the 'right' customers and generate high revenues. The 'right' price is the price that the customer is willing to pay and the hotel is willing to charge. Obviously the customers would like to pay as little as possible, while the hotels would prefer to charge as much as possible. However, if the customer feels that he has been overcharged and the price paid does not reflect the value received from the product, then future relationships between both parties are at stake. The price as a revenue management instrument is analysed in details in Chapter 11.

- *Right time*

Timing is one of the most significant concepts in revenue management. One and the same offer could be perceived differently only on the basis of when it has been made. A pre-Christmas stay promotion offered in July would most probably remain unnoticed because it is published too early. The same offer at the beginning of December might also be inefficient because it could be too late for the customers to make bookings at the hotel to use the promotion. The right time would depend on the

booking patterns of the different market segments. If the target segment usually makes most of the bookings within two weeks before the check-in date, then the optimum date for the release of the promotion might be 2-3 weeks before check-in in order for the promotion to be noticed by the potential customers.

- *Right communication*

In the context of revenue management, marketing communications of the hotel influence how its product and prices are perceived. The way information is provided on the hotel's website or how prices are presented (framed) can influence customers' perceptions about the value they (could) receive from consuming the hotel's product, and the fairness of the price conditions. This, on other hand, impacts the perceived 'price/value' ratio and customers' satisfaction from the purchase and their future purchase intentions. The role of marketing communications in value creation is elaborated in Chapter 10.

#### *The Revenue management constellation*

Revenue management includes a variety of processes, actions, and techniques sometimes difficult to summarise. Figure 1.1 provides a concept map of the revenue management constellation of terms that are discussed in detail in this book. The core of the concept maps is the relationship between the various revenue management concepts with the hotel's revenues, price, quantity and the hotel customer. Considering the fact that revenue management has a multifaceted and multi-layered nature, the concept map (Figure 1.1) should be considered as a non-comprehensive elaboration of the links among the revenue management concept.

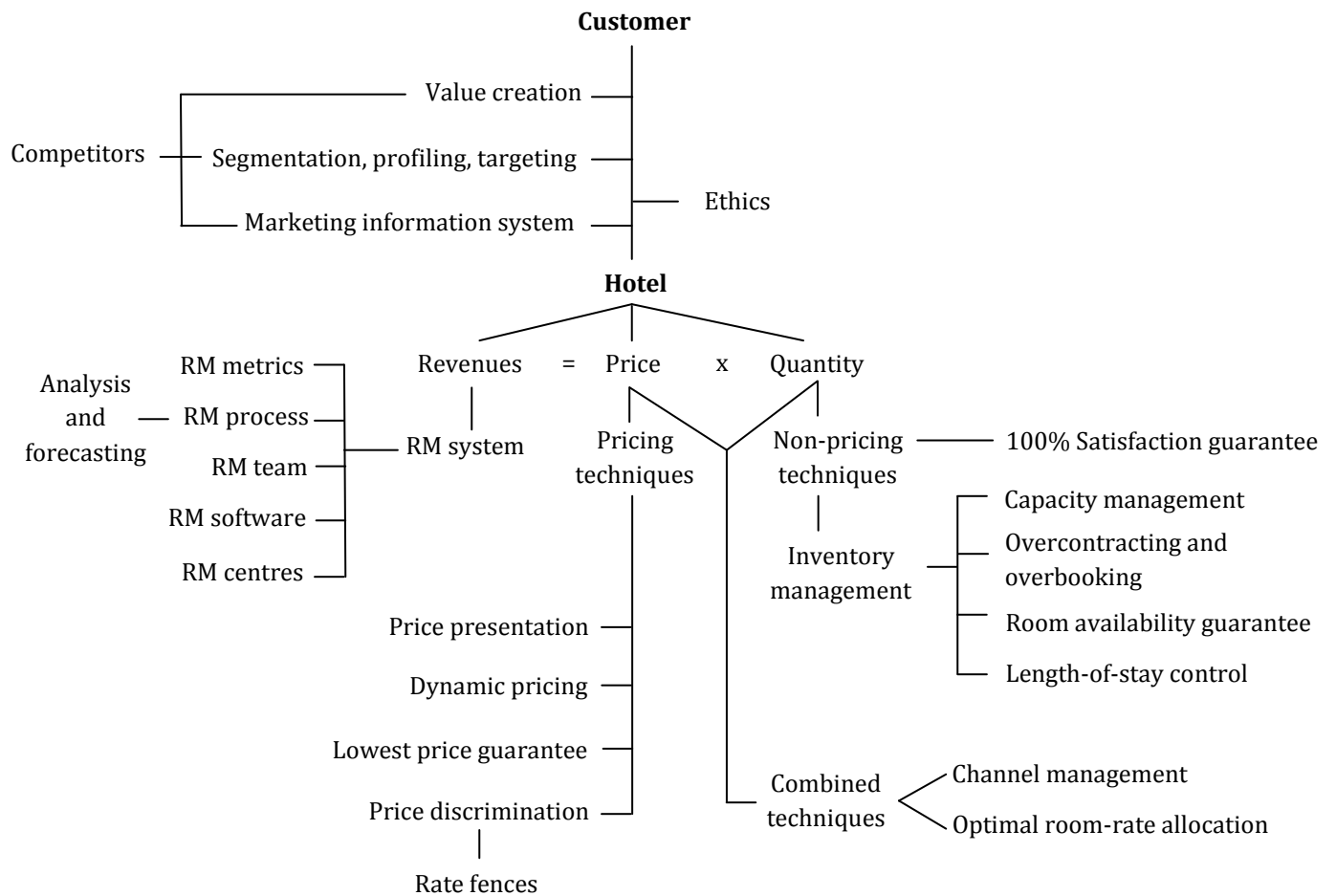

**Figure 1.1.** Revenue management constellation concept map

## Chapter 2

### ECONOMIC FUNDAMENTALS OF HOTEL REVENUE MANAGEMENT

Hotel revenue management is based on several economic fundamentals and assumptions (Ivanov & Zhechev, 2011; Kimes, 1989; Schwartz, 1998; Wirtz *et al.*, 2003) that determine the applicability of revenue management as a practice in the hotel industry:

- *Product perishability*

The hotel's product is essentially a service which cannot be stored for later consumption. Temporary excessive capacity of the hotel cannot be forwarded to periods with high demand. Production and consumption of the hotel services take place simultaneously with the active participation of the consumer. Each room that has not been used for a particular time base (overnight) cannot be sold later for a future use and the potential revenue from it is lost forever as no customer would be willing to pay for accommodation for a period already passed. Therefore, the rational hotelier tries to manage the demand through various tools to shift some of the demand for rooms from busy to slower periods, e.g. by offering alternative dates for accommodation to customers who have been denied accommodation for a particular period when the hotel is fully booked. Product perishability means that customers would look for tangible clues about the quality of the product – hotel descriptions, pictures, guest reviews, which increases the role of marketing communication in the presentation of hotel's product value.

- *Limited capacity*

Capacity can be defined as the number of customers that the hotel can service within a particular period of time. When the time base for the calculation of the capacity is one night, then the room capacity of the hotel equals the number of beds in the hotel. Some hotels also provide rooms for smaller time periods than the usual 24 hours (e.g. day let rooms or rooms let on per hour basis) which means that they could serve

more customers within 24 hours than the number of beds in the hotel which is a rational way to increase the room capacity of the hotel.

Besides room capacity, we can identify capacities for the various other revenue generating services/centres – restaurant, function rooms, spa centre, swimming pool capacity. These capacities are determined in a similar manner as the room capacity – the number of customers that could be served within a specific time period, e.g. number of customers that could take massage in one day. Similar to room capacity, the capacities of the restaurant, the spa centre, the swimming pool, etc., would depend on the number seats or deck chairs. However, besides the pure physical limitations, the capacity of these revenue centres of the hotel would also be influenced by other factors. The capacity of the restaurant, for example, would be influenced by the average time spent by the customers for a particular meal, the working hours of the restaurant, the type of service (self-service/waiter), the number of employees, etc. (see Chapter 14). The capacity of the massage service would depend on the working hours, the duration of one massage and the number of masseurs on shift. The capacity of the function rooms would be determined by the number of rooms and their layout style (banquet, cocktail, board room, U-style, classroom or theatre).

In the short run the physical room capacity of the hotel is fixed and cannot be changed – the number of rooms remains constant because adding additional rooms by building new wings, for instance, requires time. However, the hotel can decrease its room capacity in the short run by closing wings or floors. The latter is usually applied during periods of low demand in order to reduce operating maintenance costs. The capacity of the other revenue generating service centres in the hotel is relatively easily changed in the short run (e.g. more chairs and different layout of the function rooms), especially if this does not involve heavy investment in fixed assets (i.e. reconstructing the building). In the long run the capacity of every company, including the hotel, is variable.

- *High fixed and low variable costs*

Fixed costs (*FC*) are those that do not change according to the number of guests in the hotel – depreciation, debt service, salaries for administrative personnel and part of the front line employees, part of the expenses for heating/water/electricity, and

marketing expenses, among others. Usually they account for 60-80% of all costs in the hotel. Variable costs are those that change according to the number of guests in the hotel – part of the salaries for the front line employees, food product costs, heating/water/electricity for the rooms. From an economic point of view the hotel can afford to serve guests until the marginal revenue from a guest ( $MR$ ) is at least equal to the marginal costs ( $MC$ ) for serving him (Varian, 2006), i.e. when:

$$(2.1) MR \geq MC$$

The marginal room revenue is equal to the price ( $P$ ) received by the hotel for the room. Attracting one more additional customer increases the variable costs of the hotel by the variable costs per one overnight ( $VC_1$ ). Therefore, substituting  $P$  and  $VC_1$  in (2.1) we get:

$$(2.2) P \geq VC_1$$

Equation (2.2) shows that, for the hotel, it is worth serving a particular customer if the room revenues received from him cover at least the variable costs for serving him. When (2.2) is fulfilled then the hotel covers the entire variable costs for serving the customers and some of the fixed costs, which are made regardless of whether the guest is in the hotel or not. When  $VC_1$  are low then the hotel can actively use price to attract new customers and sell vacant rooms. The hotel should not lower the price below  $VC_1$  because it would lose money. However, this latter statement should not be perceived as an ultimate rule. The marginal revenues in (2.1) do not include only revenues from the rooms – guests make expenses for other services as well like F&B, spa, concierge, internet, parking, sport facilities, casino, etc., which generate additional revenues for the hotel. In some hotels these additional revenues might even be more important than the room revenues (e.g. casino hotels). Therefore, when calculating the marginal revenues hoteliers should consider all revenues generated by the customer, not only the room revenues, which is the basis of the *total hotel revenue management* concept (Buckhiester, 2012; Noone, McGuire & Rohls, 2011). Therefore, sometimes it is possible and economically rational for the price of a guest room to go below the variable costs because the additional revenues from the customer will compensate for that low price.



- *Unequal demand throughout the day/week/month/year*

Having a stable demand eliminates the need for revenue management. If, for example, every day the hotel receives between 90 and 110 booked rooms, the general manager can be sure of the occupancy rate which decreases the pressure to attract more customers. However, tourism demand is often volatile, uncertain and subject to seasonal variations depending on the product of the hotel and its location. Business hotels, for example, have higher occupancy during weekdays and lower over the weekend, while for leisure properties the situation is usually reversed. Seaside hotels are more attractive during the summer season, while fewer numbers of guests arrive during the shoulder periods. Variations in tourism demand force hoteliers to look for different instruments to manage demand – attract more customers during slow periods, attract higher paying customers and divert demand from busy to less busy periods.

- *Possibility to forecast demand*

This is one of the main assumptions of hotel revenue management, because all decisions of the revenue manager are based on the forecasts about tourism demand. If demand is chaotic and impossible to forecast within acceptable forecasting error, revenue management becomes obsolete and the optimal hotel pricing strategy would be to maintain constant prices.

- *Possibilities to segment market demand*

Applying revenue management techniques, price discrimination in particular, requires that market demand is not homogeneous, so that the hotel may apply a differentiated marketing strategy and prepare different marketing mixes for the different target segments (Kotler *et al.*, 2009). When demand cannot be segmented properly then market segmentation becomes redundant and the best marketing strategy for the hotelier would be to trade with all customers using a uniform marketing mix – same product, price, distribution channels, and communication mix. However, tourism demand is quite diverse which gives ground to hoteliers to actively use revenue management techniques.

- *Different price elasticities of market segments*

Tourism demand does not have a uniform elasticity. It varies by segment and market conditions and this provides a basis for hotels to charge different market segments

different prices. Price elasticity of demand ( $e_d$ ) is the reaction of demand to changes in prices. It is measured by the ratio between the percentage change in quantity demanded and the percentage change in a product's price (Das, 2007):

$$(2.3) e_d = \frac{dq/q_0}{dp/p_0},$$

where  $dq=q_1-q_0$  is the change in quantity demanded by customers (e.g. number of overnights) in period 1 compared to period 0, and  $dp=p_1-p_0$  is the change of price over the same period.

Usually demand demonstrates negative price elasticity (Peng *et al.*, 2014), meaning that the increase in room price leads to a decrease in the number of overnights booked in the hotel. When  $e_d < -1$  demand is *elastic* and quantity demanded changes more than the percentage change of price, i.e. a 10% increase in prices would cause a more than 10% drop of overnights sold. When  $e_d = -1$  we observe *unit elasticity* and quantity demanded changes in exactly the same proportion as price, i.e. a 10% increase in prices would cause 10% drop of overnights sold. Finally, when  $e_d \in (-1; 0)$  demand is *inelastic* and quantity demanded changes less than the price, i.e. a 10% increase in prices would cause less than 10% drop of overnights sold.

For the sake of a comprehensive discussion the author notes that there are two more situations concerning the value of the coefficient of elasticity. When  $e_d \rightarrow -\infty$  demand is *perfectly elastic* and minute changes in price cause it to drop to zero. When  $e_d = 0$  demand is *perfectly inelastic* so that it is irresponsive to changes in price (Tribe, 2005: 76). However, in field of tourism these two extremes have mostly theoretical rather than practical value because customers may always switch to another hotel if the price increases (thus eroding the perfect inelastic demand) or are loyal to brands (thus eliminating some elasticity from the perfectly elastic demand).

Price elasticity of demand should be properly estimated by the hotel manager because it is strongly connected with revenues of the hotel. The revenues of the hotel from overnights  $TR$  are:

$$(2.4) TR = p \cdot q,$$

which after differentiating is:

$$(2.5) \frac{dTR}{TR} = \frac{dp}{p} + \frac{dq}{q}$$

From (2.3) we can derive that

$$(2.6) \frac{dq}{q} = \frac{dp}{p} \cdot e_d$$

Substituting (2.6) in (2.5) and performing the mathematical operations we get:

$$(2.7) \frac{dTR}{TR} = \frac{dp}{p} (1 + e_d).$$

Therefore, the change in hotel's revenues as a consequence of price changes would depend on the demand price elasticity  $e_d$ . If demand is elastic ( $e_d < -1$ ) the hotel could increase its revenues by decreasing prices because the lost revenues from the lower prices would be overcompensated by the larger number of overnights sold. If demand is inelastic ( $e_d \in (-1; 0)$ ) then the optimal strategy is opposite – increase of the price, which would be partially offset by lost revenues from decreased number of overnights in the hotel, but the final balance would be a positive impact on revenues. If demand has unit elasticity ( $e_d = -1$ ) the hotel does not have stimuli to change prices as the gained revenues due to higher price would be entirely offset by lost revenues due to lower number of overnights sold. Table 2.1 below summarises the reaction of total revenues in relation to price changes and demand price elasticity.

**Table 2.1.** *Reaction of total revenues to price changes according to demand price elasticity*

		Price change	
		Increase	Decrease
Demand price elasticity	Elastic	TR decrease	TR increase
	Unit elasticity	TR remain the same	
	Inelastic	TR increase	TR decrease

Price elasticity of demand for hotel accommodation is determined by various factors. It is lowest when (see also Ivanov & Zhechev, 2011: 167-168):

- The customer is not aware of competing offers;

- The hotel product is unique and there are no substitutes for the product (e.g. underwater hotel);
- Consuming the product increases the prestige and social status of the customer (e.g. accommodation in a luxury hotel);
- Costs are shared among customers or expenses are covered entirely or partially by someone else (e.g. business travellers whose expenses are covered by their companies);
- Accommodation costs have a low share in the total budget of the tourist for the trip;
- The tourist is highly involved in booking a particular hotel (e.g. the hotel from the honeymoon holiday);
- The customer has already purchased other products connected with the hotel booking (e.g. flights for specific dates);
- The customer books a low number of overnights (i.e. customers booking long stays would be more price sensitive compared to customers who book only one overnight in the hotel);
- Accommodation costs constitute a small share of the customer's income (i.e. customers with higher incomes are usually less price sensitive).

The rise of online hotel bookings has introduced previously unobserved hyper-transparency on the accommodation market. Tourists can now check online availability for thousands of destinations with a myriad of hotels and suppliers and compare prices, which increases the price elasticity of demand.

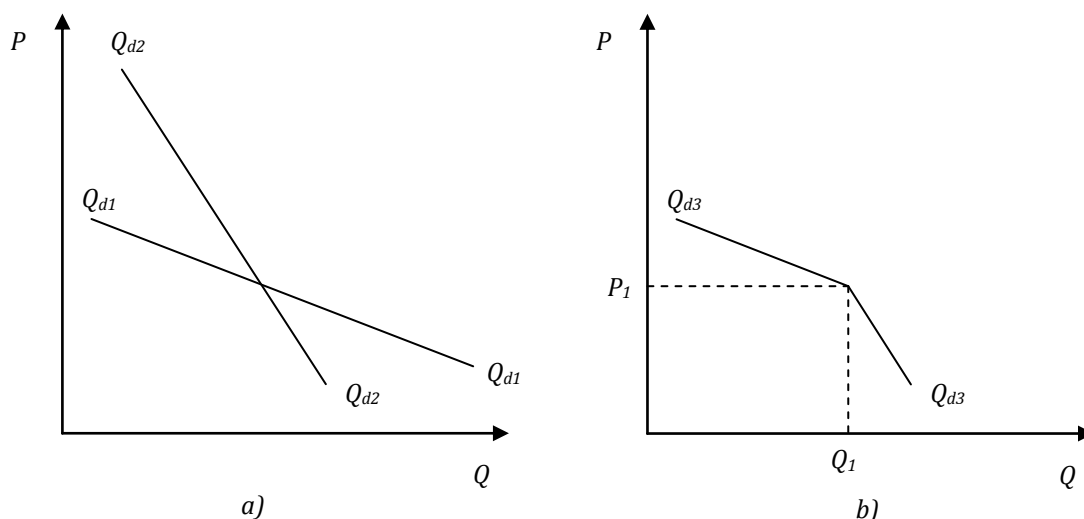

**Figure 2.1.** *Tourism demand curves*

Usually demand is depicted as a curve showing the relationship between quantity demanded and price. Figure 2.1 presents three demand curves for a particular hotel.  $Q_{d1}$  on Figure 2.1.a is the visualisation of the elastic demand while  $Q_{d2}$  depicts the inelastic tourism demand. Both demand curves assume that demand would stay elastic or inelastic at all price levels and disregard the reaction of competition. In practice, however, customers react differently to price increases and decreases (Figure 2.1.b). When the hotel increases its prices during normal business periods  $P_1$  (i.e. outside periods with local special events) without change in the value of the offered services, most probably its competitors would not follow suit. If their prices remain constant or increase less than the prices of the hotel in question, the price/value ratio changes in favour of the competitors and the hotel loses part of its price competitiveness. Tourists would find it easy to switch their bookings to competing hotels meaning that demand would be elastic, i.e. the number of overnights in the hotel will decrease more than the increase of the price and the total revenues of the hotel will actually drop. If, on the contrary, the hotel decides to decrease its prices, it is highly probable that its competitors would do the same. Therefore, its price advantage would be only temporary until competitors match the lower price, meaning that the demand would be inelastic and the increase of the quantity demanded would not be able to offset the decrease in prices. That's why, in reality, the demand curve for a specific hotel would be kinked (Figure 2.1.b) meaning that *demand is elastic to price increases and inelastic for price decreases* (see also Carroll, 2011: 179). The latter leads to the conclusion that *price wars among hotels in a destination are meaningless as they do not increase hotels' revenues but exhaust their financial resources*.

- *Different willingness-to-pay of market segments*

The willingness-to-pay is the highest price an individual is willing to accept to pay for some good or service (Braidert, 2006: 27). If the price of the product is above the customer's willingness-to-pay he would not buy it; if the price is lower, the difference between the willingness-to-pay and the price creates a consumer surplus for the buyer but lost potential revenue for the company. When different market segments are ready to pay different prices for the same product, accommodation establishments can apply price discrimination, charge them different rates according to their willingness-to-pay and erect price fences so that customers with higher willingness-to-pay do not purchase at lower rates.

- *Possibility for advanced booking*

One of the major characteristic of hotel services is that they may be booked in advance – weeks, even months before the check-in date. Advance bookings allow tourists to be guaranteed that they would receive the accommodation service sometime in the future while they provide a long time window during which hoteliers can sell their rooms. From a revenue management perspective the possibility to book hotel rooms in advance provides hoteliers with the opportunity to use time as a segmentation criterion – e.g. differentiating customers on the basis how many days before check-in they make their booking in the hotel. Furthermore, the hotelier can keep track of how bookings for a particular check-in date are accrued and react according to changes in demand.

## Chapter 3

### HOTEL REVENUE MANAGEMENT SYSTEM

From the standpoint of systems theory (von Bertalanffy, 1969), hotel revenue management can be presented as a system, illustrated in Figure 3.1. Although often the term ‘revenue management system’ is associated with RM software (see for example Baker, Murthy & Jayaraman, 2002; Legoherel, Poutier & Fyall, 2013c; Mauri, 2012) in this book, the author chooses to adopt a more broad viewpoint towards the revenue management system as seen in Figure 3.1. The RM system is defined as *the set of structural, procedural and human resource elements dedicated toward the achievement of hotel revenue management’s objectives*.

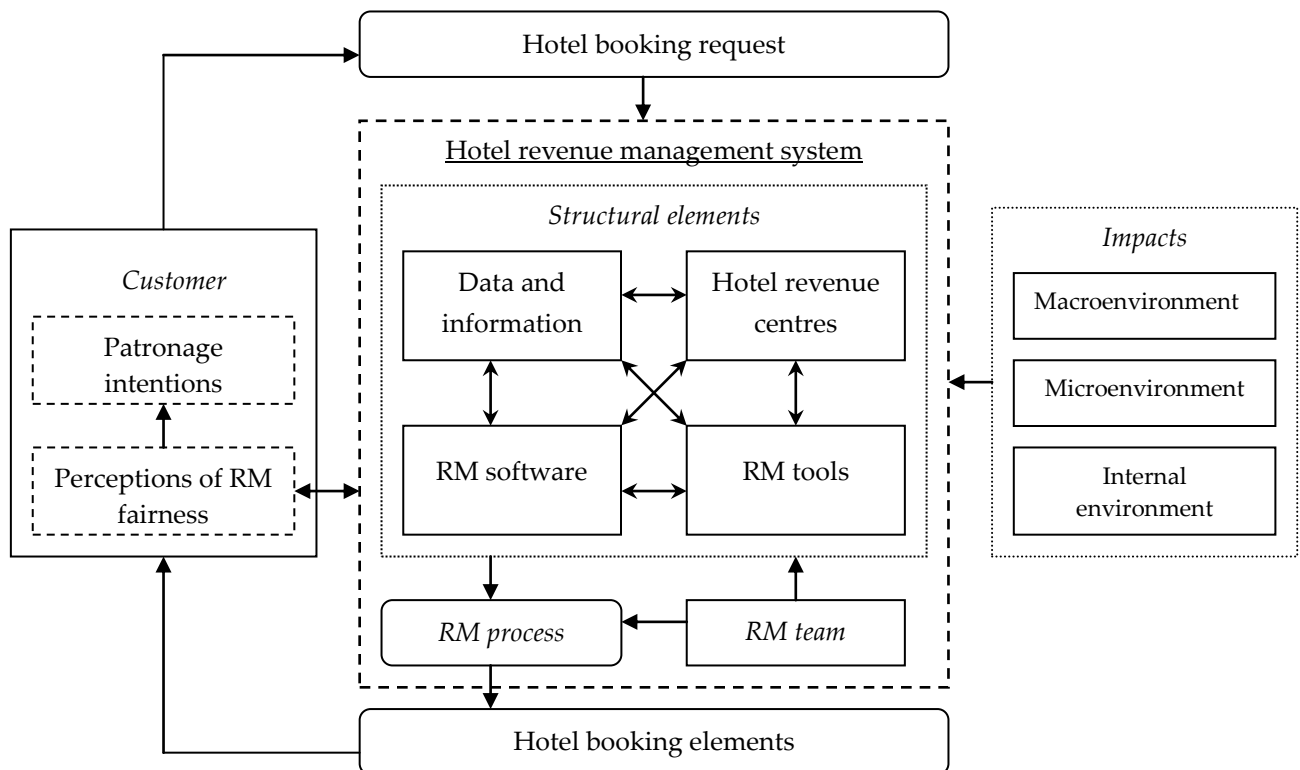

**Figure 3.1.** Hotel revenue management system (Ivanov & Zhechev, 2012)

**Table 3.1.** *Elements of hotel RM system – review of selected papers*

Research topic		Selected papers
Economic and marketing principles of hotel RM		Mauri (2012); Ng (2009a); Tranter, Stuart-Hill & Parker (2008); Vinod (2004)
RM process in general		Emeksiz, Gursoy & Icoz (2006); Guadix, Cortes, Onieva & Munuzuri (2009); Lieberman (2003); Mauri (2012); Tranter, Stuart-Hill & Parker (2008); Vinod (2004)
Consumer booking behaviour, willingness-to-pay, willingness to book		Chen & Schwartz (2006, 2008a, 2008b, 2013); Chen, Schwartz & Vargas (2011); Eslaminosratabadi (2014); Noone & Mattila (2009); Schwartz (2000); Schwartz & Chen (2010, 2012)
RM metrics (RevPAR, ADR, GOPPAR, yield, occupancy)		Barth (2002); Hoogenboom (2012); Lieberman (2003); Mauri (2012)
Operational data needed in RM		Bodea, Ferguson & Garrow (2009)
RM software / Role of technology in hotel RM		Guadix <i>et al.</i> (2009); Mauri (2012); Schwartz & Cohen (2004)
Introduction and implementation of RM function in the hotel		Donaghy, McMahon-Beattie & McDowell (1997); El Haddad, Roper & Jones (2008); Gehrels & Blonar (2012); Lockyer (2007); Okumus (2004); Talon-Ballestrero, Gonzalez-Serrano & Figueroa-Domecq (2014)
Human resource issues, the revenue manager and revenue management team, training		Beck <i>et al.</i> (2011); Lieberman (2003); Mauri (2012); Mohsin (2008); Selmi & Dornier (2011); Toilot (2013); Tranter, Stuart-Hill & Parker (2008); Varini & Burgess (2010)
Integrating RM and CRM		Noone, Kimes & Renaghan (2003); Mauri (2012); Milla & Shoemaker (2008); Wang (2013); Wang & Bowie (2009)
Measuring the impact (performance) of RM		Burgess & Bryant (2001); Jain & Bowman (2005); McEvoy (1997); Queenan, Ferguson & Stratman (2011); Rannou & Melli (2003)
Hotel revenue centres	Restaurants	Bertsimas & Shioda (2003); Heo (2013); Heo <i>et al.</i> (2013); Kimes (1999b, 2005); Kimes & Thompson (2004); Thompson (2010); Thompson & Sohn (2009)
	Function rooms	Kimes & McGuire (2001); Orkin (2003)
	Golf courses	Kimes (2000); Kimes & Schruben (2002); Licata & Tiger (2010); Rasekh & Li (2011)
	Casinos	Hendler & Hendler (2004); Kuyumcu (2002); Norman & Mayer (1997); Peister (2007)
	Spa centres	Kimes & Singh (2009); Modica & Scanu (2014)

Source: adapted from Ivanov & Zhechev (2012) and further expanded by the author



When the customer sends an email query to the hotel, calls by telephone, checks availability on the hotel's/chain's website or in an online hotel reservation system, the booking request he made is registered by the hotel's revenue management system. The RM system consists of four *structural elements* (data and information, hotel revenue centres, RM software and RM tools), the *RM process* and the *RM team*. The operational results from the RM process are the specific elements of the particular booking request – e.g. status (confirmed/rejected), number of rooms, types and category of rooms, duration of stay, price, cancellation and amendment terms and conditions, etc. Final booking details could be different from those of the initial request – for example, the hotel might confirm a different room type, or propose alternate dates. The booking details and the operation of the whole RM system influence customer's perceptions of the fairness of hotel's RM system and his intentions for future bookings with the same hotel/hotel chain. If the customer feels he has been treated unfairly he would not consider booking at the same hotel in the future. The RM system experiences constant influences of the external (macro- and micro-) and internal environmental factors in which the hotel operates (e.g. company's goals, its financial situation, legislation, competition, changes in demand, destination's image, or force majeure events among others) and a revenue manager's decisions must take all these into consideration. The way the RM system is organised and especially the applied software, accumulated data, and the taken decisions influence the competitiveness of the accommodation establishments. Therefore the RM system must be considered as intellectual property and treated as a trade secret (Kimes & Wagner, 2001). Table 3.1 summarises the main directions of hotel RM system elements research. Due to their importance, separate tables are dedicated to present research on RM tools, forecasting and approaches used for solving RM mathematical problems.

This chapter focuses on the structural elements of the RM system, the RM team and potential impacts on the RM system. Due to their significance, the RM process and ethical issues (perceived fairness) are discussed in separate chapters.

### *3.1. Structural elements of the revenue management system*

The hotel RM system includes four structural elements, namely: revenue centres, data and information, RM tools, and RM software.

- *Hotel revenue centres*

Hotel revenue centres determine the potential sources of revenues for the hotel (rooms division, F&B, function rooms, spa & fitness facilities, golf courses, casino and gambling facilities, and other additional services) and the capacity of the hotel to actively use pricing as a revenue generation tool. From a practical point of view, the broader the sources of revenues the better. Having a wider scope of revenue sources increases the opportunities of the hotel to sell more services to customers and to actually generate higher revenues – not only from guest rooms, but from additional services as well. Hotel revenue management research up to now has focused overwhelmingly on the Rooms Division and its related problems – most notably price discrimination and overbookings. However, it is important that the hotel’s revenue management system includes all revenue centres, not only the guest rooms, because they can significantly contribute to the hotel’s total revenues and financial results. As mentioned in Chapter 2, for some types of properties, like casino hotels, guest rooms might even be a secondary revenue source.

The fact that besides the rooms the hotel can have additional revenue centres complicates the revenue management process. Instead of maximising room revenues only, revenue managers must now focus on the revenues of the hotel as a whole, i.e. to apply a total hotel revenue management approach. This justifies the arising interest in the application of revenue management principles and tools in related hospitality industries and hotel revenue centres (Table 3.1) – restaurants (Bertsimas & Shioda, 2003; Heo, 2013; Kimes, 2005; Kimes & Thompson, 2004), function rooms (Kimes & McGuire, 2001; Orkin, 2003), casinos (Hendler & Hendler, 2004; Kuyumcu, 2002; Norman & Mayer, 1997), spa centres (Kimes & Singh, 2009), golf courses (Licata & Tiger, 2010; Rasekh & Li, 2011). In most cases, the additional revenue centres will generate income only if the guests are already accommodated in the hotel, although some guests might use only the additional hotel services without room accommodation (e.g. use of spa centre, F&B, conference facilities). In this regard, the goal of maximising guest room revenues might not be consistent with the total revenue maximisation objective. Revenue managers might decrease room rates in order to attract additional guests to the hotel that will subsequently increase the demand for the other revenue centres, although Murphy, Semrad & Yost (2013) found in their research that discounting room rates during the low season did not significantly influence in-house restaurant sales. In practice, many hotel chains have

long recognised the importance of additional services as revenue source and have adopted proper revenue management strategies to generate revenues from them. RM software used by them also includes modules for the additional revenue centres. However, from a research point of view, up to now, the additional revenue centres have been studied as *separate* business units, and not as integrated with revenue management of the Rooms Division department. In this regard, it is necessary that the hotel revenue management research incorporates them into the revenue maximisation problem of the hotel in search of *total* hotel revenue management.

- *Data and information*

The application of RM requires a lot of data regarding different revenue metrics – average daily rate (ADR), revenue per available room (RevPAR), gross operating profit per available room (GOPPAR), occupancy, yield, profit per available room, etc. (Barth, 2002; Lieberman, 2003; Hoogenboom, 2012; Mauri, 2012). Additionally, the revenue management system requires information about a hotel’s future bookings on a daily basis (what types and how many rooms), sale of additional services in the other revenue centres, competitors’ rates and strategies, information regarding changes in legislation, special events to take place at the destination, and any other data/information that relates to the demand, supply, revenues and financial results of the hotel. Albeit their importance, RM metrics and data requirements seem somewhat neglected in the hotel RM research field. Academic literature on hotel RM accepts the metrics *per se* while only a few authors analyse the metrics’ DNA in details (most notably Hoogenboom, 2012). RM metrics are discussed in detail in Chapter 5.

- *RM tools*

Revenue management involves the utilisation of different RM tools, which are defined as instruments by which hotels can influence the revenues they get from their customers. RM tools can be broadly divided into pricing, non-pricing and combined tools (Table 3.2).

Pricing tools (Chapter 11) include price discrimination, the erection of rate fences, dynamic and behavioural pricing, lowest price guarantee and other techniques that *directly* influence a hotel’s prices (their level, structure, presentation and price rules). Non-pricing tools (Chapter 12) do not influence pricing directly and relate to inventory control – capacity management, overbookings, length-of-stay control, room

availability guarantee. Combined RM tools (Chapter 12) include distribution channel management and optimal room-rate allocation. They influence both the price of the hotel service and the number of rooms available at each rate (see Figure 1.1). All three groups of tools (pricing, non-pricing and combined) are intertwined and applied simultaneously – for instance, prices vary not only by room type, lead period or booking rules, but by distribution channel as well.

**Table 3.2.** *Revenue management tools – review of selected papers*

Research topic		Selected papers	
<i>Non-pricing RM tools</i>			
Inventory management	Capacity management in general	Mauri (2012); Pullman & Rogers (2010)	
	Overbookings	Optimal level of overbookings	Hadjinicola & Panayi (1997); Ivanov (2006, 2007a, 2014); Koide & Ishii (2005); Netessine & Shumsky (2002)
		Walking guests	Baker, Bradley & Huyton (1994); Ivanov (2006)
	Length of stay control		Ismail (2002); Kimes & Chase (1998); Vinod (2004)
	Room availability guarantee		Noone, Kimes & Renaghan (2003)
<i>Pricing RM tools</i>			
Pricing in general		Collins & Parsa (2006); Hung, Shang & Wang (2010); Shy (2008)	
Price discrimination and rate fences		Guillet, Law & Xiao (2013); Hanks, Cross & Noland (2002); Kimes & Wirtz (2003); Mauri (2012); Ng (2009b); Shy (2008); Tranter, Stuart-Hill & Parker (2008)	
Dynamic pricing		Abrate, Fraquelli & Viglia (2012); Aziz <i>et al.</i> (2011); Bayoumi <i>et al.</i> (2013); Mauri (2012); Palmer & McMahon-Beattie (2008); Tranter, Stuart-Hill & Parker (2008)	
Price presentation/framing, discounting		Croes & Semrad (2012a, b); Enz, Canina & Lomanno (2004); Noone & Mattila (2009)	
Lowest price guarantee		Carvell & Quan (2008); Demirciftci, Cobanoglu, Beldona & Cummings (2010)	
<i>Combined RM tools</i>			
Optimal room-rate allocation (room distribution)		Baker, Murthy & Jayaraman (2002); Bitran & Gilbert (1996); Bitran & Mondschein (1995); El Gayar <i>et al.</i> (2011); Guadix <i>et al.</i> (2010); Harewood (2006)	
Channel management		Choi & Kimes (2002); Hadjinicola & Panayi (1997); Myung, Li & Bai (2009); Tranter, Stuart-Hill & Parker (2008)	

Source: Adapted from Ivanov & Zhechev (2012), amended and expanded by the author

- *RM software*

The processing of large databases is impossible without appropriate RM software (Guadix *et al.*, 2009; Mauri, 2012; Pucciani & Murphy, 2011) and hotels that employ it gain a strategic advantage over those that rely on intuitive decisions only (cf. Emeksiz, Gursoy & Icoz, 2006) and have improved financial performance (Koushik, Higbi & Eister, 2012; Pekgun *et al.*, 2013). Some of the software packages include:

- ✓ EzRMS™ – <http://www.easyrms.com/core.php>
- ✓ Opera – <http://www.micros.com/Solutions/HotelsAndResorts/>
- ✓ PROS – <http://www.pros.com/solutions/pricing-effectiveness/pricing-solutions/>
- ✓ JDA Pricing and Revenue Management – <http://www.jda.com/solutions/pricing-revenue-management/>

RM software usually includes several modules. The *database module* contains and analyses enormous amounts of primary data on bookings:

- number of bookings
- length of stay
- lead period
- number of guest rooms in one booking
- prices by distribution channels and market segments
- historical information on no-shows, walk-ins and denials
- historical booking patterns (booking curves)
- historical cancellation patterns, etc.

The *demand modelling module* is used to generate the mathematical model of demand for a particular property, while the *forecasting module* is used to forecast demand and the values of the RM metrics. The *controls and recommendations module* gives suggestions on price amendments, inventory control and channel management. Despite the high level of sophistication of RM software the ultimate RM decision, however, lies in the hands of the revenue manager and his/her team.

It should be noted that the RM software influences the decision making process of revenue managers. Firstly, the software analyses huge databases and provides forecasts based on the optimisation models embedded in it. If the mathematical models are flawed, then the forecasts will be flawed and the revenue manager's

decisions will be irrelevant to the situation. On the other hand, as Schwartz & Cohen (2004) demonstrate, the interface of the software and how information is presented in the software impacts the judgment of revenue managers and their inclination to adjust the computer's forecasts. Therefore, RM software forecasts should be used as guidelines, not as ultimate decisions.

### *3.2. Revenue management team*

Human resource issues are essential in RM system planning and implementation (Beck *et al.*, 2011; Lieberman, 2003; Mohsin, 2008; Noone & Hultberg, 2011; Selmi & Dornier, 2011; Tranter, Stuart-Hill & Parker, 2008; Zarraga-Oberty & Bonache, 2007) and authors agree that revenue managers and RM teams are vital for the success of any RM system (Tranter, Stuart-Hill & Parker, 2008). In many hotel companies the application of RM techniques is the responsibility of a single person who may or may not specialise solely in revenue management. This is especially valid for independent hotels which do not have the financial resources (nor is it necessary) to form a separate revenue management team. In these hotels RM activities are performed by the general manager, the marketing manager and/or the front office manager, depending on the size of the property and the existence of the specific job position. Very small properties and family hotels employ too few people to afford a separate revenue manager or even a marketing manager. In these hotels the revenue management is usually one of the responsibilities of the general manager or the front office manager. Mid-sized hotels might have a separate marketing manager who deals with revenue management as well. Only large and upscale properties generate enough revenues to justify and financially sustain a separate revenue manager position. However, large hotel chains have long recognised the importance of revenue management to their bottom line and have appointed a separate revenue manager (Mainzer, 2004: 287) or even regional revenue management teams (Tranter, Stuart-Hill & Parker, 2008) to head and guide company's efforts in optimal management of its revenues. Nevertheless, regardless of whether a separate revenue manager is appointed, the basic revenue management and sales techniques must be understood and applied by every staff member involved in the sales of hotel's services (front office, reservations department, F&B outlets, spa/fitness and other additional services) in order to boost sales and revenues of the hotel. This is especially valid for upselling (sale of higher priced products) and cross-selling (sale of additional products offered by other departments in the hotel). For example, the front

office might inform guests at check-in about offers in the restaurant. Therefore employees must have knowledge about all services offered by the hotel at any moment and be regularly trained in sales techniques. In this context, Lieberman (2003) emphasises the specific knowledge and training revenue management specialists need to be effective and efficient – marketing, finance, forecasting.

The introduction and the implementation of the RM system in a hotel and the RM software as its more visible part in particular (Donaghy, McMahan-Beattie & McDowell, 1997; El Haddad, Roper & Jones, 2008; Lockyer, 2007; Okumus, 2004) is a challenging and significant change that might cause some resistance among employees which should be addressed properly. Resistance might arise due to misunderstanding regarding the role of revenue management in the strategic, tactical and operational management of the property, insufficient clarifications about the goal and objectives of RM, overlapping responsibilities between different departments/personnel, fear of the unknown, or numerous other reasons. In any case, when the hotel management team tries to introduce the revenue management philosophy in the hotel, it must be done with care, considering all internal stakeholders affected by it.

### *3.3. Impacts on the RM system*

- *Macroenvironment*

The macroenvironment of the hotel includes those factors from the external environment which it cannot influence, but should consider and try to adapt to. Usually the macroenvironment is analysed in the six PESTEL dimensions (political, economic, social, technological, environmental and legislative) each of which impacts, although at varying degree, the revenue management system of the hotel.

Legal and technological factors have the strongest influence on a hotel's RM system. Legislative factors determine whether the application of the RM tools is even allowed by law and how these tools maybe applied. Article 27 (3) from the Bulgarian Consumer Protection Act, for example, explicitly says that the "designation of different prices for the same service in particular premises is prohibited. If, however, different prices are given for the same service, the customer pays the lower price". This means that price discrimination might be considered illegal by Bulgarian authorities. That's why after the introduction of the Consumer Protection Act in 2006,

publishing different prices for domestic and foreign guests in accommodation establishments became illegal which led to increased prices for domestic tourists. Therefore accommodation establishments in Bulgaria should carefully determine the conditions and price levels in their contracts with distributors and the prices they publish on their websites and at the reception of the hotel in order to avoid subsequent legal sanctions. Similar regulations exist in other countries.

The development of information and communication technologies (ICT) has allowed hoteliers to use a multitude of distribution channels. From one side this has provided the hotel with enormous revenue management opportunities such as reaching customers from various countries and segments effectively and cost efficiently, applying dynamic pricing, gathering information on customers on an individual level and applying microsegmentation. On the other hand, ICTs have introduced unprecedented transparency about the prices and pricing strategies adopted by hotels. Through the OTAs (*Booking.com, Venere.com, Expedia.com, Orbitz.com*) customers can now easily check the prices for hundreds of hotels at a particular destination, while through meta search engines (like *Kayak.com, Hotelscombined.com, Trivago.com*) they may even compare prices of the same hotel via the different OTAs and select the lowest price. This has led to greater price elasticity of the customers (they have more information about the market offers) and to a certain degree of commodification of the hotel product (customers shop for the best bargain and have lower loyalty to brands). Furthermore, the prices are visible not only to customers but to competitors, and can therefore be easily matched within minutes/hours, thus eliminating any temporary price advantage one hotel might have had over its competitors at a destination.

The economic (economy size, purchasing power parity, economic growth, economy's stage in the business cycle, balance of payments, inflation, exchange rates, unemployment, etc.), social (population size, natural growth of population, ethnic structure, travel and paid leave preferences, etc.), political (political stability), and environmental factors often directly influence the RM system of a hotel by their impact on tourism demand. For instance, in periods of high economic growth both business and leisure travel demand increase, therefore, decreasing the need for price promotions in hotels. When the local currency appreciates too much, the local hotel industry loses its price competitiveness over other destinations and inbound tourism



demand drops, thus forcing hotels to apply various RM tools to stimulate demand. Preferences of people when to take paid leave and go on a holiday may influence traditional seasonality patterns in the revenues of the hotel. Political unrest in the country would dissuade many travellers from taking the trip leading to significant pressure on hotels' revenues, prices and number of overnights.

- *Microenvironment*

The microenvironment includes those actors from hotel's external environment whose behaviour the company can possibly influence through the elements of its marketing mix. In a narrower context the microenvironment includes its customers, the competitors, and distributors. In a wider context the microenvironment also may include the media, various social/interest groups, financial and marketing partners of the hotel, and the general public. Obviously each of these actors may have a profound direct impact on a hotel's RM system. The preferences, purchasing power, characteristics of the customers determine the mix of the pricing, non-pricing and combined RM tools that the hotel applies. The behaviour of competitors determines the decisions made by the hotel, the distributors help the hotel sell its product and generate revenues, while the media publications may cause some revenue management practices to be more or less acceptable (e.g. media coverage of overbookings). Therefore, the hotel should always keep track of the developments in its microenvironment in order to be prepared to implement timely and proactive RM decisions.

- *Internal environment*

The internal environment includes the factors within the company that could shape its RM system, its scope and/or the way it functions. In particular, here we could include the marketing and financial objectives of the hotel, the decision-making and organisational system of the property, its financial situation. If the objective of the hotel's management team is the maximisation of the RevPAR, the RM decisions to be taken will be somewhat different compared to a situation when the objective is to maximise the GOPPAR. Furthermore, if the hotel does not have an RM manager and the RM function is the responsibility of the general manager of the hotel, RM might not reach its full potential because the general manager may not have the time, knowledge and/or skills to apply all RM techniques, because (s)he might simply be overwhelmed with routine operational decisions such as housekeeping, repairs, staff

turnover, or relations with the hotel owner. Finally, if the hotel is struggling financially, the strategy to protect the rooms for the highest paying customers might step back in favour of a strategy aimed at attracting most (or any!) customers.

## Chapter 4

### HOTEL REVENUE MANAGEMENT PROCESS

The revenue management process is the set and sequences of actions undertaken by revenue managers on strategic, tactical and operational level in relation to managing the revenues of the hotel. Tranter, Stuart-Hill & Parker (2008) identify eight steps in the RM process – customer knowledge, market segmentation and selection, internal assessment, competitive analysis, demand forecasting, channel analysis and selection, dynamic value-based pricing, and channel and inventory management. It is evident that these authors' steps of the RM process are derived from the general marketing management practice, which is understandable, considering the fact that revenue management developed into the realm of marketing management. Emeksiz, Gursoy & Icoz (2006) propose a more comprehensive hotel revenue management model that includes five stages, namely: preparation, supply and demand analysis, implementation of revenue management strategies, evaluation of revenue management activities and monitoring and amendment of the revenue management strategy. The main advantage of the Emeksiz *et al.* (2006) model is the inclusion of qualitative evaluation and constant monitoring of the chosen revenue management strategy. Vinod (2004: 181) takes a more pragmatic approach to identifying the steps in revenue management application and distinguishes the following steps in the RM process: market segmentation, inventory pooling, demand and supply forecasting, overbooking controls, revenue mix controls, performance measurement and management reporting. Mauri (2012) provides a literature review of the different viewpoints on the content of the revenue management process.

It is obvious that the authors identify more or less similar activities/steps/stages in the RM process. The RM process is reported to include segmentation, analysis, forecasting demand and supply, application of various RM tools, and monitoring and evaluation of activities. This book adopts the Ivanov & Zhechev (2012) 7-stage revenue management process elaborated in Figure 2. Segmentation is not considered

as a stage in the *revenue* management process but as part of the larger *marketing* process of the hotel (Ivanov & Zhechev, 2011:15).

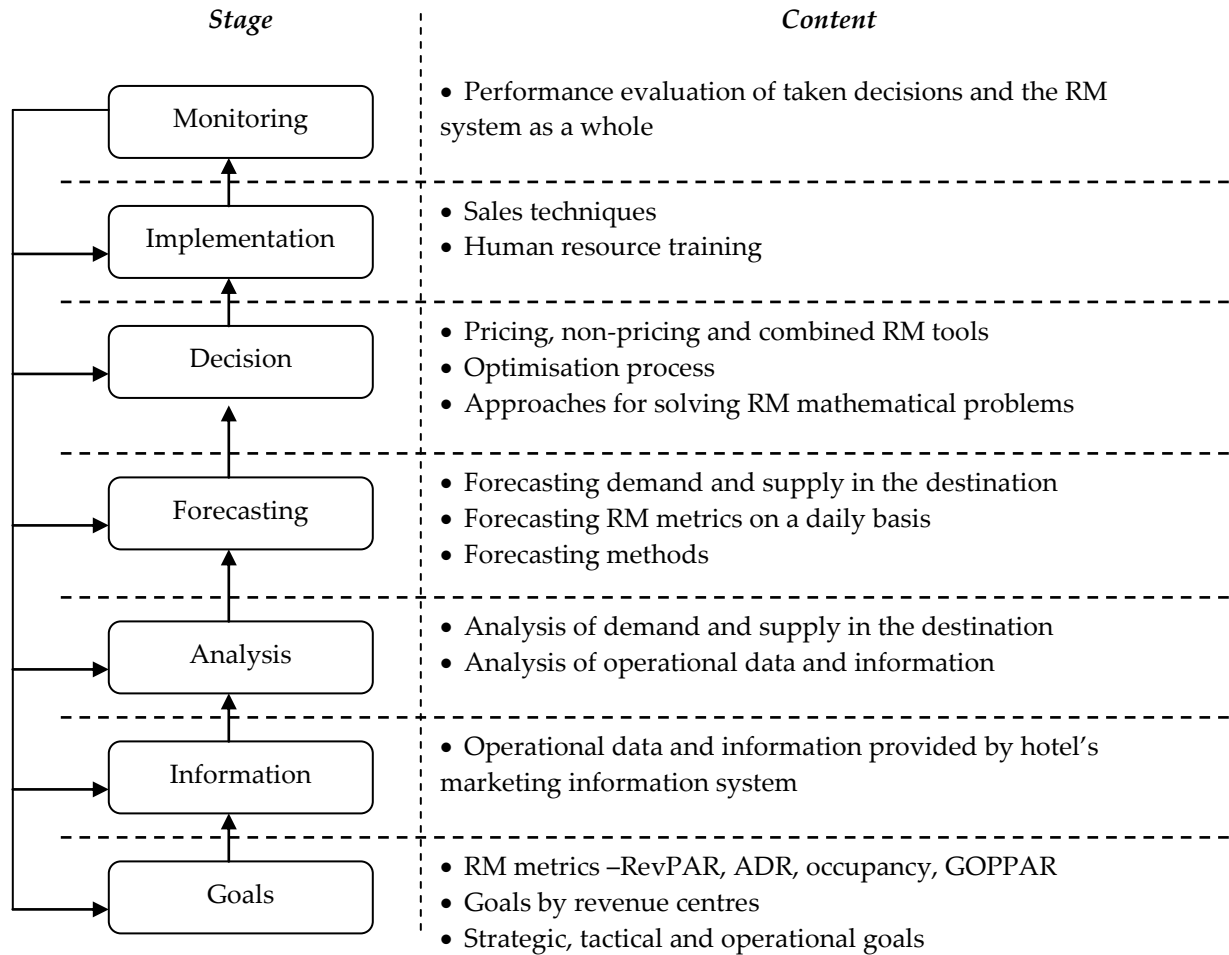

**Figure 4.1.** *Hotel revenue management process* (adapted from Ivanov & Zhechev, 2012)

- *RM goals*

At the start of the RM process the revenue manager, the general manager and/or the owner of the hotel set the goals of the revenue management of the hotel with a specific strategic (several years), tactical (weeks/months) and operational (days) time horizon (Ivanov and Zhechev, 2011: 304). These goals relate to the values of different RM metrics (RevPAR, ADR, occupancy, GOPPAR) to be discussed in detail in Chapter 5. It is important that goals are SMART:

✓ *Specific* – the goal relates to a particular metric. ‘Being profitable’ is not considered a specific goal as it is too generic. ‘Achieving RevPAR ...’ is a very specific and suitable RM goal.

✓ *Measurable* – the goal has a numerical expression, i.e. ‘Achieving RevPAR of 85 euros ...’. The measurability of the goal serves as a prerequisite for effective monitoring of the RM process as the target value of the metric is used as a criterion whether the goal has been achieved or not.

✓ *Achievable* – the goal is set within reasonable limits. It is unjustified to set a goal for RevPAR for a three-star at the level of a four-/five-star hotel.

✓ *Realistic* – the goal is supported by marketing activities and financial budget. A goal of 10%-increase of RevPAR without necessary marketing actions and financial resources would be overly optimistic.

✓ *Time-bound* – the goal includes a deadline, i.e. ‘Achieving RevPAR of 85 euros in 2015’.

Separate sets of strategic, tactical and operational goals may be formulated for the different revenue centres in the hotel (the F&B outlets, function rooms, spa & fitness facilities, golf courses, casino and gambling facilities, and additional services) on the basis of revenue centre’s specific RM metrics. Setting the RM goals is important, for several reasons:

- ✓ RM goals visualise the targets towards which the hotel is moving;
- ✓ *SMART* RM goals provide a basis for evaluating the work of the revenue manager/RM team;
- ✓ RM goals help the RM team form a consensus about its objectives.

- *Data and information gathering*

The second stage of the RM process includes the gathering of necessary operational data and information provided by the hotel’s marketing information system. It will be analysed in details in Chapter 7.

- *Analysis*

During the third stage of the RM process, operational data is analysed to provide the revenue manager with clues about the trends in the hotel’s RM metrics for the forthcoming days/weeks. This stage also involves analysis of demand (on the level of an individual hotel, chain properties at a destination and on destination level), and

the lodging supply at the destination (opening/closing/reflagging properties). Analysis will be further elaborated in Chapter 8.

- *Forecasting*

The revenue manager makes decisions on the basis of forecasts about the demand, supply and development of various RM metrics. Therefore good RM forecasts are a prerequisite for good RM decisions. Forecasting will be the subject of Chapter 9.

- *Decision*

Forecasts from the previous stage feed the mathematical models within the RM software to produce recommendations for the optimal levels of prices, rate structures, overbookings, and help the revenue manager make proper decisions (e.g. closing of lower room rates). Table 4.1 summarises the approaches used by researchers to solve RM mathematical problems in these models.

**Table 4.1.** *Approaches for solving revenue management mathematical problems – review of selected papers*

Approach	Selected papers
Deterministic linear programming	Goldman <i>et al.</i> (2002); Liu, Lai & Wang (2008)
Integer programming	Bertsimas & Shioda (2003)
Dynamic programming	Anderson & Xie (2012); Aslani, Modarres & Sibdari (2013); Badinelli (2000); Bertsimas & Shioda (2003)
Markov model	Rothstein (1974)
Bid-price methods	Baker & Collier (1999, 2003)
Price setting method	Baker & Collier (2003)
Expected marginal revenue technique	Ivanov (2006, 2014); Netessine & Shumsky (2002)
Stochastic programming	Goldman <i>et al.</i> (2002); Lai & Ng (2005); Liu <i>et al.</i> (2006); Liu, Lai & Wang (2008)
Probabilistic rule-based framework in Knowledge Discovery technique	Choi & Cho (2000)
Simulation (including Monte Carlo)	Baker & Collier (2003); Rajopadhye <i>et al.</i> (2001); Zakhary <i>et al.</i> (2011)
Fuzzy goal programming model	Padhi & Aggarwal (2011)
Robust optimisation	Koide & Ishii (2005); Lai & Ng (2005)

Source: adapted from Ivanov & Zhechev (2012) and expanded by the author

Review of available revenue management literature shows the predominance of stochastic programming (Goldman *et al.*, 2002; Lai & Ng, 2005; Liu *et al.*, 2006; Liu, Lai & Wang, 2008) and simulations (Baker & Collier, 2003; Rajopadhye *et al.*, 2001;

Zakhary *et al.*, 2011) as approaches to solving RM mathematical problems. Other methods like deterministic linear programming (Goldman *et al.*, 2002; Liu, Lai & Wang, 2008), integer programming (Bertsimas & Shioda, 2003), dynamic programming (Badinelli, 2000; Bertsimas & Shioda, 2003), fuzzy goal programming (Padhi & Aggarwal, 2011), and robust optimisation (Koide & Ishii, 2005; Lai & Ng, 2005) have received less, but growing attention. Finally, techniques such as bid-price and price setting methods (Baker & Collier, 2003), and expected marginal revenue technique (Ivanov, 2006, 2014; Netessine & Shumsky, 2002) have not been applied widely in the field of hotel revenue management. To some extent the reasons may be attributable to the stochastic nature of hotel bookings (in terms of lead period, number of overnights, number of rooms, type of rooms, fare class, etc.) which requires stochastic programming and simulations. On the other hand, the expected marginal revenue technique provides greater simplicity of calculations and is more practically applicable on a daily basis without the need for costly and complex software. However, the aspiration of researchers and practitioners to model hotel operations and market demand as realistically as possible leads to the construction of more multifarious RM problems requiring innovative and more sophisticated approaches to solve them.

As mentioned earlier, RM software provides *recommendations* to the RM manager about the application of the different RM tools. However, the RM manager (or the person whose responsibilities include managing the revenues of the hotel regardless of their title) should make the decision. In particular, the decision could relate to:

- Opening/closing dates for sale to all or specific market segments;
- Opening/closing particular price levels for bookings to all or specific market segments;
- Changes in overbooking limits for specific dates;
- Confirming/denying specific booking requests;
- Amending price levels by distribution channel;
- Amending booking terms by distribution channel (requirements for credit card guarantee, prepayment, cancellations and amendments, etc.);
- Setting/amending requirements for minimum length of stay (minimum number of overnights), etc.

In practice, decisions of the RM software may also be *automated*. When the RM software is integrated in real time with the computer reservation system and the website of the hotel (chain), it is possible for its website to visualise different rates to different customers during different search times but for one and the same check-in/stay-through date, depending on the number of already accrued bookings for that particular date at the time of the search and how often accommodation for that date has been searched for via the website of the hotel (chain). This saves time for the revenue manager and provides opportunities for real time revenue management and dynamic pricing without direct operational involvement of the manager. However, the lack of human contact would mean that it is possible the website to visualise a higher price than necessary and dissuade the customer from booking. If the customer has an account on the website of the hotel (chain) and has signed in, he would be identified and the appropriate prices would be visualised. However, in most cases the user does not sign in when searching for information only. But when revenue managers and software developers look for other clues hinting the 'right prices' to be visualised (e.g. previously visited websites, information for which is obtainable via the 'cookies', or the operating system used to access the website of the hotel (chain)) this may cause ethical concerns among customers, i.e. the practice of Orbitz to visualise to Apple users hotels with average higher prices compared to PC users has caused the company very bad publicity (Mattila & Choi, 2013). Therefore, automated decision making should be limited to the most basic decisions like opening/closing specific price levels when the number of accrued bookings has reached/fallen below specific predetermined limit in order to avoid ethical complications.

- *Implementation*

Once the RM decision has been made it must be implemented. All staff members involved in sales should be informed about the decision if they have not participated in the decision-making process. Operational decisions involving the next few days/weeks could be announced by email and/or during the morning meetings between hotel staff, general, marketing, front office and revenue managers. The importance of tactical and strategic decisions may be further elaborated during quarterly/annual staff meetings.

Implementation of the decisions requires that the staff be trained to apply numerous sales techniques (such as upselling or cross-selling) in order to close a sale at a higher



rate or reject a booking for a shorter stay with the expectation to sell a guest room for a longer one and thus achieve RM goals. This further requires specific selling abilities (Weilbaker & Crocker, 2001) and constant training of sales personnel (Beck *et al.*, 2011). The term 'upselling' involves a sales technique by which the seller offers to a customer a more expensive product or additional services to already purchased goods/services. For instance, the administrator could offer the prospective customer a superior room at a higher price that allows free cancellation instead of the lower non-refundable rate for a standard room. If the customer cannot afford the price, the administrator could then gradually lower the price (against stricter cancellation conditions and lower room category) until a proposition is accepted by the customer up to a predetermined limit (see also Hanks, Cross & Noland, 2002). Such Dutch auction, starting with a high price and its sequential decrease by the seller until accepted by the buyer (Menezes & Monteiro, 2005), would elicit a higher average room price than immediately offering the lowest price. Upselling occurs also when at check-in the administrator offers the customer an upgrade to the next higher category room for additional payment. 'Cross-selling' is a sales technique in which an employee in one department of the hotel informs the customer about and offers services/products provided by other departments in the hotel, e.g. when the administrator informs the guest at check-in about offers in the restaurant or the services in the spa centre. If the customer books online via the hotel (chain) website, the upselling could be performed automatically as explained in the previous paragraph. The website could also provide the customer the option to book additional services (cross-selling) either at the time of booking or after the booking for the rooms has been confirmed.

- *Monitoring*

Finally, the revenue management process includes the monitoring and evaluation of all stages in the process and searching for opportunities to improve it at every stage. Specifically, monitoring and evaluation might reveal that:

- ✓ Goals are too ambitious (not 'achievable'), too low (if the salaries of the revenue management team depend on their performance in reaching specific RM metrics targets they are interested in setting lower goals in order to receive higher bonuses), or not accepted by the people who have to achieve them;

- ✓ The hotel's marketing information system is not providing the proper information, it produces too much information (yielding shallow analysis due to data

overload) or too little information (thus no in-depth analysis), or information is not provided in a timely manner;

- ✓ Analysis is altogether missing and therefore is too shallow, its results are ignored, or the revenue management team are obsessed with the analysis or overconfident with their conclusions;

- ✓ Forecasting is based on unrealistic assumptions and demand models, does not cover all relevant variables or is overly complicated (i.e. no significant forecasting accuracy gain from using a more sophisticated forecasting technique instead of a simpler one);

- ✓ Decision is not related to the results of the analysis or the forecasting, or not understood/accepted by the employees who have to implement it;

- ✓ Employees involved in the sales of various services in the hotel are not implementing the decisions, or 'it's-not-my-job' culture is cultivated in the hotel (i.e. sales are perceived as responsibility solely of the sales team).

Monitoring and evaluating the RM process is required not only when the revenue management team fails to achieve their objectives, but also when it reaches and, especially, outperforms them. It may turn out, that due to unusually strong demand the hotel (chain) surpassed its RM goals so that this achievement should not be entirely attributed to the revenue management. It may also turn out that the objectives have been deliberately set at low levels, so that the RM team could easily achieve them and receive greater bonuses. Anyway, regardless of the results of the monitoring process, all identified issues should be addressed properly and in a timely manner.

Revenue management should be applied only if it contributes positively to the hotel's bottom line. This requires measuring the performance of hotel's RM system and process (Burgess & Bryant, 2001; Jain & Bowman, 2005; McEvoy, 1997; Rannou & Melli, 2003) on individual property or chain level (Sanchez & Satir, 2005). Authors agree that revenue management, like any investment, is worth when the increased revenues from its application offset the additional costs related to it. Cross *et al.* (2009: 73) suggest that the "revenue generation index", calculated as the ratio of hotel's RevPAR divided by the RevPAR of the competitive set, is a more accurate assessment of revenue productivity for a particular property, especially when considering the economic environment in which the hotel is operating. Same authors also discuss the

“revenue opportunity index” calculated as the ratio between actual and optimal (maximum) revenue that could have been achieved by the hotel. However, regardless of the performance measures used, they have to be applied systematically in order to provide comparability of hotel’s results in a given time period. In practice, this may take the form of RM reports prepared on a suitable time basis (daily, weekly, monthly, quarterly, or annually).

## Chapter 5

### HOTEL REVENUE MANAGEMENT METRICS

Hotel revenue management uses various metrics that show the effectiveness and the efficiency of the hotel to generate revenues (Mauri, 2012). Some of them measure the performance of the revenue management system and process in the hotel and are specific for the industry, while others are more general and relate to the financial health of the company (e.g. profitability and liquidity ratios). In this chapter we shall analyse only the RM performance metrics used by the different revenue centres of the hotel. Financial ratios are widely discussed in financial management literature (e.g. Bull, 2008; Gibson, 2012; Walsh, 2006) and go beyond the scope of this book.

#### Rooms division

- *Number of overnights*

The number of overnights is the simplest statistic used in the hotel industry. Despite its simplicity this is a very useful metric as it measures the physical volume of consumption in the Rooms Division. It is the most basic metric in the hotel revenue management because it is used in the calculation of all other RM metrics. As a variation of the metric it is used the number roomnights (often refer to as 'number of occupied rooms') – the number of rooms that have been occupied for a particular period of time regardless of the number of people in each room.

- *Occupancy rate*

The occupancy rate measures the utilisation of the physical capacity of the hotel. It can be measured in two ways – using overnights or roomnights as a basis:

$$(5.1.) \text{Occupancy}_{\text{overnights}} = \frac{\text{Number of overnights}}{\text{Number of beds available for sale}} \cdot 100$$

$$(5.2.) \text{Occupancy}_{\text{roomnights}} = \frac{\text{Number of roomnights}}{\text{Number of rooms available for sale}} \cdot 100$$

Due to various reasons (e.g. repair works, temporary technical problems or accommodation of employees), some of the guest rooms of the hotel are blocked and not designated for sale to guests. The rest will be considered available for sale. Considering the facts that hotels have rooms with different number of beds, the number of different room types in a particular hotel is not equal, the demand for the different room types is not equal, extra beds could be added to some rooms for particular nights and fewer guests could be accommodated in the room than its maximum capacity, the occupancy rates calculated on the basis of roomnights and overnights might be different. The occupancy rate shows the ability of the hotel to generate revenues in an *extensive* way, i.e. by increasing the number of guests/nights/sold rooms. It varies depending on:

- Day of the week – higher during weekdays for business hotels and lower during weekends. For leisure properties the situation is reversed – higher occupancy during weekends and lower on weekdays.

- Period of the year – alludes to the seasonality of tourism activities. Seaside hotels have higher occupancy during summer season, while mountain properties could have double peaks – higher in winter and lower in summer.

- Market segments – business travellers prefer to stay in single rooms. Usually hotels do not offer many proper single rooms and accommodate single guests in double rooms for single use. This action does not influence the occupancy rate measured by roomnights, but decreases the occupancy rate measured by overnights as fewer guests have been accommodated in the double rooms than rooms' capacity.

- Special events – events like exhibitions, conferences, congresses, festivals, or sport games attract a lot of visitors to the destination and increase the demand for accommodation and the occupancy rates of hotels.

- Factors like destination accessibility, competitors' actions, the marketing strategy and activities of the hotel, product quality and other factors that impact the demand for the product of the particular hotel.

- *Average daily rate (ADR)*

The ADR relates to the average price charged by the hotel for one overnight (equation 5.3.) or roomnight (equation 5.4.). This statistic reflects the ability of the hotel to generate revenues *intensively* from occupied rooms, i.e. by achieving higher prices rather than more overnights/roomnights. It can be calculated for every room type

separately (e.g. standard, superior, deluxe, executive rooms, studios, suites, etc.) or for the hotel as a whole.

$$(5.3.) ADR_{overnights} = \frac{\text{Room revenues}}{\text{Number of overnights}}$$

$$(5.4.) ADR_{roomnights} = \frac{\text{Room revenues}}{\text{Number of roomnights}}$$

The ADR depends on:

- Day of the week – business hotels have higher rates during weekdays and lower during weekend days. Similar to occupancy rate, the opposite situation is observed in leisure properties – higher prices during weekend days and lower for weekdays.

- Period of the year – higher prices during main tourist season and lower prices during shoulder and low season periods.

- Market segments – if the hotel charges different prices by market segment.

- Special events – during special events demand for accommodation increases which eliminates the need for promotions to stimulate it. Therefore the ADR rises (see Herrmann & Herrmann (2014) for an example of the impact of 2012 Oktoberfest on prices of hotels in Munich).

- Contract conditions, price levels and booking terms by distribution channels used by the hotel – if the hotel achieves higher rates in its contracts with intermediaries, the ADR will increase.

- The types of rooms booked by customers – more expensive rooms drive up the ADR of the hotel.

- Other factors that impact the demand for the product of the particular hotel discussed in the previous paragraph.

ADR is an intuitive metric, straightforward, and easy to calculate and understand by hotel managers, employees and investors. That's why it is widely used in the industry. However, a major criticism is that it considers only room revenues. As Mauri (2012) pinpoints, for a budget hotel, guest room revenues may well account for nearly all of its revenues but for a luxury business/leisure/golf/casino hotel room, revenues may be around or even less than half of its total revenues, which justifies the use of the next metric – the total revenue per occupied room.

- *Length-of-stay*

Length-of-stay shows the average number of overnights spent by guests in the hotel:

$$(5.5.) \text{ Length - of - stay} = \frac{\text{Number of overnights}}{\text{Number of guests}}$$

Transit motels and airport hotels usually show very low length-of-stay statistics (slightly above 1 night), business city hotels – around 2-3 nights, while leisure hotels – 5-7 or more overnights. Length-of-stay is related to the costs and revenues from the guests. Longer guest stays require less frequent change of laundry, which decreases slightly the variable costs, while increase the opportunities for the hotel staff to sell additional services to those guests. Longer stays also decrease the number of check-ins and check-outs, thus lowering the workload for the Front Office and Housekeeping departments. That’s why hotels usually offer discounts to guests with longer stays either in the form of a lower room rates or by free additional nights (e.g. “Stay 7, pay 6 overnights”).

- *Total revenue per occupied room (Total RevPOR)*

This metric is calculated similarly to the ADR but instead of the room revenues only the nominator includes the total revenues of the hotel.

$$(5.6.) \text{ Total RevPOR} = \frac{\text{Total revenues}}{\text{Number of roomnights}}$$

The main advantage of this metric is that it considers the revenues from ancillary services. Besides the factors that impact the ADR, the total RevPOR depends on the variety of additional services offered by the hotel and the employees’ selling and cross-selling skills.

- *Revenue per available room (RevPAR)*

ADR and occupancy rates alone cannot be measures of the effectiveness and efficiency of the revenue management system of the hotel because having a high ADR or high occupancy does not necessarily mean high revenues – a high ADR can actually be achieved at a very low occupancy, while a low ADR – at a very high occupancy. That’s why it is best if both metrics (occupancy and ADR) be used together involving the metric named ‘revenue per available room’ (RevPAR). It measures room revenues generated by the hotel per one room available for sale

(equation 5.7.) and is considered as one of the most important metrics in the hotel industry.

$$(5.7.) \text{ RevPAR} = \frac{\text{Room revenues}}{\text{Number of rooms available for sale}}$$

RevPAR can also be calculated as the product of ADR and the occupancy rate:

$$(5.8.) \text{ RevPAR} = \text{ADR}_{\text{roomnights}} \cdot \text{Occupancy}_{\text{roomnights}}$$

Equation (5.8.) shows that the RevPAR is influenced by both the occupancy rate and ADR, and depends on the factors that influence each of them. Therefore the hotel can achieve a higher RevPAR by increasing the occupancy (extensive growth), the ADR (intensive growth), or by adjusting both. It should be noted that ADR and occupancy have an inverse relationship. When the hotel increases its room rates its ADR rises but occupancy drops; when prices decrease the ADR falls but the occupancy rate increases. Therefore, it is possible that the hotel has the same RevPAR at various levels of occupancy and ADR. Similar to ADR the RevPAR disregards revenues from additional services but nevertheless, again, it is the most widely used performance metric in hotel revenue management.

- *Total revenue per available room (Total RevPAR)*

Total RevPAR overcomes the disadvantage of the RevPAR by taking into consideration the revenues from additional services as well. It is the product of the total RevPOR and the occupancy rate.

$$(5.9.) \text{ Total RevPAR} = \frac{\text{Total revenues}}{\text{Number of rooms available for sale}}$$

$$(5.10.) \text{ Total RevPAR} = \text{Total RevPOR} \cdot \text{Occupancy}_{\text{roomnights}}$$

Obviously the total RevPAR is the best metric for analysing the effectiveness of the revenue management to generate revenues as it integrates all above metrics. It has, nevertheless, one disadvantage – it disregards the *costs* for generating the revenues. Measuring and analysing costs is important. It may turn out that the hotel is achieving very high total RevPAR but at the expense of high costs that decrease or



even entirely eliminate the profit of the hotel. This disadvantage is overcome by the next metric – the gross operating profit per available room.

- *Gross operating profit per available room (GOPPAR)*

The GOPPAR is the most useful metric available to revenue managers because it considers the revenues and costs simultaneously. It is calculated by (Dopson & Hayes, 2009: 299):

$$(5.11) \text{ GOPPAR} = \frac{\text{Gross operating profit}}{\text{Number of rooms available for sale}}$$

The gross operating profit (*GOP*) of the Rooms Division is the difference between the total room revenues (*TR*) and the total room costs (*TC*):

$$(5.12) \text{ GOP} = \text{TR} - \text{TC}$$

Total room costs include variable (*VC*) and fixed costs (*FC*):

$$(5.13) \text{ GOP} = (\text{TR} - \text{VC}) - \text{FC}$$

Revenues are the product of the *ADR* and the number of roomnights sold (i.e. the number of occupied rooms). Variable costs are the product of the variable costs per one roomnight (*VC<sub>1</sub>*) and the number of occupied rooms:

$$(5.14) \text{ GOP} = (\text{Roomnights} \cdot \text{ADR} - \text{Roomnights} \cdot \text{VC}_1) - \text{FC}$$

$$(5.15) \text{ GOP} = \text{Roomnights} \cdot \text{ADR} \cdot \frac{(\text{ADR} - \text{VC}_1)}{\text{ADR}} - \text{FC}$$

Considering that

$$(5.16) \text{ Gross profit margin} = \text{gpm} = \frac{(\text{ADR} - \text{VC}_1)}{\text{ADR}},$$

we come to:

$$(5.17) \text{ GOP} = \text{Roomnights} \cdot \text{ADR} \cdot \text{gpm} - \text{FC}$$

By substituting (5.17) in (5.11) we arrive at:

$$(5.18) \text{ GOPPAR} = \frac{\text{Roomnights} \cdot \text{ADR} \cdot \text{gpm}}{\text{Number of rooms available for sale}} - \frac{\text{FC}}{\text{Number of rooms available for sale}}$$

Taking into account (5.2) and (5.8) we can conclude that (Hoogenboom, 2012: 3):

$$(5.19) \text{ GOPPAR} = \text{ADR} \cdot \text{gpm} \cdot \text{Occupancy} - \text{FCPAR}$$

$$(5.20) \text{ GOPPAR} = \text{RevPAR} \cdot \text{gpm} - \text{FCPAR}$$

where *FCPAR* are the fixed costs per available room.

Equations (5.19) and (5.20) reveal that hoteliers may increase GOPPAR by raising the ADR, the occupancy rate, RevPAR and the gross profit margin and/or by decreasing the fixed room costs. The GOPPAR can be calculated for each source of revenues, not only from guest rooms but also F&B, retail sales, and other services in the hotel. Then the total GOPPAR of the hotel would be equal to the sum of the GOPPARs for each revenue source/centre. Considering the fact that GOPPAR deals with profit, not revenues, it is considered to be the most important revenue metric for the future (Kimes, 2011; Mauri 2012).

- *Yield*

The yield is the ratio showing what percentage of the maximum potential revenues for a particular period (usually one night) the hotel has actually generated:

$$(5.21) \text{ Yield} = \frac{\text{Actual revenues}}{\text{Maximum revenues}} \cdot 100$$

$$(5.22) \text{ Yield} = \frac{\text{Number of roomnights} \cdot \text{ADR}}{\text{Number of rooms available for sale} \cdot \text{Rack rate}} \cdot 100$$

$$(5.23) \text{ Yield} = \text{Occupancy} \cdot \frac{\text{ADR}}{\text{Rack rate}} \cdot 100$$

$$(5.24) \text{ Yield} = \frac{\text{RevPAR}}{\text{Rack rate}} \cdot 100$$

It is obvious that the yield is proportionate to the RevPAR and in an inverse relationship to rack rate. This means that every time the hotel changes its rack rate, yield changes as well, even in the case of constant other variables. Therefore in order to generate comparable results in time, the rack rate should not be changed

frequently and this is also advisable from a market positioning perspective. Often in practice, the rack rate is just a nominal rate at which only too few bookings are made.

### Restaurant

For hotel food and beverage outlets the revenue manager may use a different set of metrics, specific to the restaurant business.

- Average check

$$(5.25) \text{ Average check} = \frac{\text{Total restaurant revenues}}{\text{Number of served guests}}$$

This is a measure of the average customer bill. It is the restaurant equivalent of the ADR. The average check depends on:

- Period of the day (lunch or dinner).
- Market segment – business travellers tend to spend more money at the restaurant because they receive per diem allowances from their company to cover subsistence costs unlike leisure travellers who are spending their own income during travel.
- Restaurant visit occasion – people tend to spend more money during restaurant visits on special occasions, e.g. wedding anniversary, business lunch/dinner, etc.
- Prices of individual menu entrees.
- Duration of stay in the restaurant – when customers stay longer in the restaurant it is more likely that they will consume more food and drinks but this decreases the table turnover and fewer customers will be served by the restaurant during a given period of time.

- Revenue per available seat-hour (RevPASH)

Kimes (1999b) and Thompson & Sohn (2009) emphasise the use of the RevPASH metric for assessing the efficiency of revenue management in restaurants.

$$(5.26) \text{ RevPASH} = \frac{\text{Total restaurant revenues}}{\text{Seats} \cdot \text{Working hours}} = \frac{\text{Number of served guests} \cdot \text{Average check}}{\text{Seats} \cdot \text{Working hours}}$$

The RevPASH measures the revenues generated by the restaurant per available seat per one hour. It is the equivalent of the RevPAR metric in the Rooms Division.

Similar to RevPAR, it can be increased extensively by serving more guests and intensively by achieving a higher average check per guest. On the other hand, the number of customers served will depend on the average meal duration – the shorter the duration of the meal, the more customers may be served at a table during a given period of time.

Function rooms

For measuring revenue management performance of function rooms (conference/meeting rooms, ball room), the revenue manager can use the following time- and capacity-based metrics.

- Revenue per rented square metre-hour (RevPSMH)

$$(5.27) \text{ RevPSMH} = \frac{\text{Total function room revenues}}{\text{Rented capacity} \cdot \text{Rented hours}}$$

If the hotel has only one function room which can only be rented as a whole, the rented capacity would be equal to the maximum capacity of the function rooms so the denominator of (5.27) would include the rented hours only. If the hotel has two or more function rooms it would be better if the rented capacity is measured in square metres rather than number of seats because the seating capacity of the function rooms depends on their layout. RevPSMH is conceptually equivalent to ADR. It illustrates the average rental price of the function rooms per square metre per hour.

- Occupancy

Occupancy of function rooms is measured by:

$$(5.28) \text{ Occupancy}_{\text{function rooms}} = \frac{\text{Rented capacity} \cdot \text{Rented hours}}{\text{Capacity available for rent} \cdot \text{Hours available for rent}}$$

It is increased when more square metres are rented (extensive growth) and for more hours (intensive growth). Occupancy will depend on the types of meetings function rooms could host, the flexibility of their space (i.e. the possibility to divide one room into two or merge two neighbouring rooms), or the variety of rooms that facilitate different meetings simultaneously without hindering one another.

- Revenue per available square metre-hour (RevPASMH)

$$(5.29) \text{ RevPASMH} = \frac{\text{Total function room revenues}}{\text{Capacity available for rent} \cdot \text{Hours available for rent}}$$

$$(5.30) \text{ RevPASMH} = \text{RevPSMH} \cdot \text{Occupancy}_{\text{function rooms}}$$

RevPASMH illustrates what revenues function rooms generate per one square metre and per hour available for rent. It is the equivalent of the RevPAR. RevPASMH increases when RevPSMH and occupancy rate increase.

### Spa centre

Revenue performance of a spa centre is measured by the following set of time- and capacity-based metrics:

- Average revenue per guest

$$(5.31) \text{ AR} = \frac{\text{Total spa revenues}}{\text{Number of treatments}}$$

- Occupancy

Occupancy measures the actual number of treatments as a percentage of the maximum capacity of the spa centre, i.e.:

$$(5.32) \text{ Occupancy}_{\text{spa}} = \frac{\text{Number of treatments}}{\text{Maximum number of treatments per hour} \cdot \text{Working hours}}$$

It depends on the maximum number of guests that can be served within one hour and the number of working hours of the spa centre.

- Revenue per available treatment hour (RevPATH) (Kimes & Singh, 2009)

$$(5.33) \text{ RevPATH} = \frac{\text{Total spa revenues}}{\text{Maximum number of treatments per hour} \cdot \text{Working hours}}$$

$$(5.34) \text{ RevPATH} = \text{ARC} \cdot \text{Occupancy}_{\text{spa}}$$

RevPATH is the spa equivalent of the RevPAR, therefore these share similar characteristics.

### Casino

Some revenue management metrics in a casino include:

- Average bet per customer

$$(5.35) \text{ Average bet} = \frac{\text{Monetary value of the bets}}{\text{Number of bets}}$$

It is calculated separately for the different table games (dice, roulette, blackjack, baccarat, etc.).

- Hands per hour

$$(5.36) \text{ Hands per hour} = \frac{\text{Total number of hands}}{\text{Number of hours the table is open}}$$

This is calculated for each table separately and illustrates the speed (pace) of the game. The casino is interested in higher game pace (more hands per hour) in order to generate higher revenues.

- House advantage – shows the theoretical statistical probability of win for the casino. From a revenue management perspective it impacts the number and mix of table and slot games to be offered by the casino. Higher house advantage generates higher revenues as percent of the bet but may dissuade customers from betting.

- Average daily theoretical revenue (ADT) (Hendler & Hendler, 2004: 75)

$$(5.37) \text{ ADT} = \frac{\text{Total gambling revenues from a player}}{\text{Number of days a player gambled}}$$

ADT is the amount of money a player spends in the casino per day.

- Revenue per square foot/metre

$$(5.38) \text{ Revenue per square foot/metre} = \frac{\text{Total revenues of the casino}}{\text{Area of the casino in sq.feet/metres}}$$

This space-related metric shows how effectively the casino utilises its limited space to generate revenues.

- Profit per square foot/metre

$$(5.39) \textit{ Profit per square foot/metre} = \frac{\textit{Profit of the casino}}{\textit{Area of the casino in sq.feet/metres}}$$

This metric is analogical to the revenue per square foot/metre and measures the effectiveness of the casino to generate profit from its limited space.

- Casino win on a player level (Peister, 2007: 72)

$$(5.40) \textit{ Casino win} = \textit{Average bet} \cdot \textit{Hands per hour} \cdot \textit{Time played} \cdot \textit{House Advantage}$$

This metric illustrates the amount of money a casino retains from player's bets.

- Win per available seating hour (WPASH) (Peister, 2007: 72) is a casino's equivalent of RevPAR:

$$(5.41) \textit{ WPASH} = \frac{\textit{Total casino win}}{\textit{Number of seats} \cdot \textit{Number of working hours}}$$

WPASH is influenced positively by the amount of the average bet per player, the number of hands one plays per hour, the time spent playing and the house advantage. Therefore, casino managers are interested in increasing the values of these metrics.

### Golf course

- Tee time interval

Golf courses allow golfers to start their rounds at specific moments and the interval between two consecutive moments is the tee time interval. Longer tee time intervals mean that fewer groups will be able to use the golf course. If the tee time interval is 10 minutes there will be six rounds starting per hour, while if intervals are every 12 minutes – only 5 rounds will be played every hour.

- Number of available rounds

$$(5.42) \textit{ Number of available rounds} = \frac{\textit{Working time of the golf course in minutes}}{\textit{Tee time interval}}$$

This metric shows the maximum number of rounds available to golfers on a particular day.

- Course utilisation

$$(5.43) \text{ Course utilisation} = \frac{\text{Number of used rounds of golf}}{\text{Number of available rounds}}$$

Course utilisation may be perceived as the occupancy rate of the golf course.

- Round duration

This is the amount of time it takes for a player to go through all the holes on the course. Shorter rounds mean fewer players will be on the course at any given moment and shorter tee time intervals may be set.

- Revenue per utilised round (RevPUR)

$$(5.44) \text{ RevPUR} = \frac{\text{Total revenues from the rounds of golf}}{\text{Number of used rounds of golf}}$$

RevPUR is conceptually identical to Total RevPOR in the Rooms Division.

- Revenue per available tee time (RevPATT) (Kimes, 2000)

$$(5.45) \text{ RevPATT} = \frac{\text{Total revenues from the rounds of golf}}{\text{Number of available rounds}}$$

This metric is the Total RevPAR equivalent in the golf industry.

RM is a constantly evolving field. It is recommended that the revenue manager of the hotel is not be restricted to the above metrics but delve deeper and, why not, develop his/her own metrics that will contribute both to the theory and practice of hotel revenue management.



## Chapter 6

### MARKET SEGMENTATION, PROFILING AND TARGETING

Segmentation refers to the process of dividing the consumers into distinct groups with similar set of needs and wants requiring the development of different marketing mixes by the hotel. Consumers within each segment are homogeneous on one or more segmentation criteria but may be very heterogeneous on other criteria. From a revenue management perspective segmentation is used to identify the 'right' customer(s) for the hotel. As segmentation and types of tourists have been widely discussed in tourism and hospitality marketing literature (e.g. Bowie & Buttle, 2011; Hudson, 2008; Ivanov & Zhechev, 2011; Kotler, Bowen & Makens, 2006; Morrill, 2007; Kozak & Martin, 2012; Wearne & Morrison, 2011), this chapter concentrates only on those segmentation issues relevant to hotel revenue management and will omit the general discussion of the segmentation process.

The necessity for segmentation stems from the fact that the hotel which offers a product for the 'average' customer satisfies no one – for some customers the product would be too expensive, for others – of too low category, for third – with too limited additional services, while another may not be interested in extensive services at all. Customers differ in their needs, wants, desires and preferences toward the product characteristics, travel motives, booking period, travel period, purchase occasions, purchase volume, attitude toward the brand of the hotel chain, hotel selection criteria, willingness to pay, buying power, etc. On the other hand, many customers share *common* preferences and for them the hotel could offer the same product, sell it via the same distribution channels, communicate the same product value and charge the same price. These customers, for whom the hotel uses the same marketing mix, form a market segment.

Hotel managers can use a variety of segmentation criteria. Appendices 6.1 and 6.2 present sample lists of segmentation criteria and market segments that may be

considered by hoteliers for segmenting the tourists and organisational customers, respectively. Segmentation criteria in the two appendices are hierarchically ordered into two levels – synthetic and analytic criteria (Rakadzhiiska, Marinov & Dyankov, 2013). Synthetic criteria are general broad approaches for segmentation consisting of one or more analytic criteria used to identify the particular segments. The diversity of segmentation criteria is wide and there is no need to use all of them – hoteliers should use only those criteria that are relevant to their type of accommodation establishments and influence the buyer behaviour and the decision making process of the tourists and the organisations. Several segmentation criteria may be used simultaneously. However, the more segmentation criteria used, the greater the number and the smaller the size of the market segments.

Segmenting the market is not an easy task – the identified market segments should fulfil the following requirements (see also Bowie & Buttle, 2011; Kotler, Bowen & Makens, 2006; Morritt, 2008):

- ✓ *Discrete* – the segment has a unique set of needs, wants, requirements and expectations that require the development of a special marketing mix.

- ✓ *Mutually exclusive* – the segments formulated by a particular segmentation criterion should not be overlapping, i.e. one customer belongs to one segment identified by that criterion, not to two or more.

- ✓ *Measurable* – the segment must be approximately measured in terms of size (number of potential tourists / organisations within the segment), sales volume, growth, market shares.

- ✓ *Profitable* – the segment is large enough and financially attractive to justify entry and the development of a special combination of marketing mix elements.

- ✓ *Accessible* – the segment is reachable via the distribution network of the hotel.

- ✓ *Stability* – the segment is relatively stable and is expected to exist into the near future.

- ✓ *Actionable* – the hotel could influence the behaviour of the identified market segment with the marketing mix.

Segmentation based on synthetic criteria like geography, demography, technical and organisational characteristics of the trip and travel motives usually produces market

segments that fulfil all the above criteria. It is relatively easy to apply, intuitive and statistical data on some of the segments are readily available or cheap to obtain. That's why they are the most widely used both in practice and in travel industry market reports. On the other hand, psychographic and behavioural segmentation produce segments that might be more relevant for the hotel, but their main disadvantage is the difficult measurability. Nevertheless, regardless of the segmentation criteria used, formulated market segments should be carefully evaluated in terms of their size, sales volume, profitability, competition within the segment and revenue management characteristics in order to assess their attractiveness. Table 6.1 below summarises the revenue management profiles of some selected market segments, while Table 6.2 illustrates the same for special events organised in a hotel.

Once market segments have been identified and their profiles developed, the revenue manager should select the target market segment based on their attractiveness and the strengths (and weaknesses) of the hotel. The attractiveness of the market segment is based on segment size, profitability, expectations of the customers, competition by other hotels (chains) within the segment. The hotel may target only one segment – e.g. roadside motels target the transient car travellers, while some hotels in Amsterdam are marketed as gay hotels. The hotel may also target several segments simultaneously. However, the compatibility of selected market segments should be taken into account. Some customer groups should not be accommodated in the hotel at the same time– e.g. teenager groups with senior travellers, sport teams with guests for balneology and rehabilitation, school children with LGBT guests. Of course, the hotel may accommodate all these groups but this should likely take place at different times. However, if they have to be accommodated at the same time, potentially conflicting segments should be located in different wings/floors of the hotel and, if possible, have different time schedules for use of the restaurant and other facilities of the hotel to avoid complaints. In any case, the marketing mix of the hotel should be developed in line with the characteristics, preferences and expectations of the selected target market segments. From a revenue management perspective the customer mix of the hotel is important because it influences directly its revenues and profitability. As discussed in Chapter 1 the hotel should focus on the 'right' market segments it can serve profitably and whose expectations it can meet properly.

**Table 6.1. Revenue management profiles of selected market segments**

<b>Market segment</b>	<b>Revenue management characteristics</b>
<i>Fully independent tourists (FIT)</i>	<ul style="list-style-type: none"> <li>✓ Often travel by car</li> <li>✓ Travel during weekends or paid leave periods</li> <li>✓ Direct bookings or via travel agencies</li> <li>✓ Shorter length-of-stay – 1-6 overnights</li> </ul>
<i>Leisure tourists (charter programmes)</i>	<ul style="list-style-type: none"> <li>✓ Groups with fixed arrival and departure dates</li> <li>✓ Longer length-of-stay – 7-14 overnights</li> <li>✓ Bookings via tour operators</li> <li>✓ Look for accommodation near tourist resources</li> <li>✓ High seasonality of demand</li> <li>✓ Look for economic food and beverage outlets</li> </ul>
<i>Senior travellers</i>	<ul style="list-style-type: none"> <li>✓ High price elasticity</li> <li>✓ Travel mostly during shoulder periods</li> </ul>
<i>Leisure tourists (bus excursion groups)</i>	<ul style="list-style-type: none"> <li>✓ Groups with very short length-of-stay – 1-3 overnights</li> <li>✓ Bookings via tour operator – rarely direct bookings (e.g. school excursions)</li> <li>✓ Tourists often share common characteristic – interests, school, workplace</li> <li>✓ Look for accommodation near tourist resources or with excellent transport accessibility, often in the outskirts</li> <li>✓ High seasonality of demand</li> </ul>
<i>Business travellers (business trips)</i>	<ul style="list-style-type: none"> <li>✓ Short length-of-stay – 1-3 overnights</li> <li>✓ Accommodation during weekdays</li> <li>✓ Direct bookings or via a travel agency</li> <li>✓ Look for accommodation near their work place at the destination</li> <li>✓ Lower seasonality of demand</li> <li>✓ Low price elasticity</li> <li>✓ Use additional business services – fax, copier, scanner</li> <li>✓ Need a room with a working desk</li> <li>✓ Need internet access</li> </ul>
<i>Business travellers (special events)</i>	<ul style="list-style-type: none"> <li>✓ Book large number of rooms</li> <li>✓ Direct bookings or via travel agencies</li> <li>✓ Length-of-stay 1-5 overnights depending on the special event</li> <li>✓ Tourists share common characteristic – interests, profession, workplace</li> <li>✓ Low price elasticity</li> <li>✓ Additional services used – function rooms, catering</li> </ul>
<i>Business travellers (teambuilding)</i>	<ul style="list-style-type: none"> <li>✓ Book large number of rooms</li> <li>✓ Guests are usually employees of or connected with one company (e.g. distributors)</li> <li>✓ Accommodation during weekends</li> <li>✓ Short length-of-stay (1-3 overnights)</li> <li>✓ Direct bookings or via travel agencies</li> <li>✓ The company is price sensitive as it covers all expenses for accommodation</li> <li>✓ Use a lot of additional services – function rooms, restaurants, spa, sport facilities</li> </ul>
<i>Families with children</i>	<ul style="list-style-type: none"> <li>✓ High price elasticity</li> <li>✓ Travel during weekends, holiday periods, school vacations</li> <li>✓ Use a lot of additional services – babysitting, video games, retail</li> </ul>

<b>Market segment</b>	<b>Revenue management characteristics</b>
<i>Flight crews</i>	<ul style="list-style-type: none"> <li>✓ Only one overnight stay</li> <li>✓ Possible room rent without an overnights, i.e. day let</li> <li>✓ Transfer required from/to the airport</li> <li>✓ Require recreational facilities</li> </ul>
<i>Sport teams</i>	<ul style="list-style-type: none"> <li>✓ Book large number of rooms for the team and the accompanying persons – trainers, doctors</li> <li>✓ Varying from 1 (during competition) to 14-21 overnights (training camps)</li> <li>✓ Comfort and training facilities take priority over price</li> <li>✓ Use a lot of additional services</li> </ul>
<i>Transit travellers</i>	<ul style="list-style-type: none"> <li>✓ One overnight stay at airports or roadside motels/hotels</li> <li>✓ Look for economic accommodation</li> <li>✓ Require transfer from/to the airport (for airport hotels)</li> </ul>
<i>Shopping travellers</i>	<ul style="list-style-type: none"> <li>✓ Short length of stay – 1-3 overnights</li> <li>✓ Accommodation in/near shopping area or malls</li> <li>✓ Might require transfer to shopping malls</li> </ul>
<i>Medical tourists</i>	<ul style="list-style-type: none"> <li>✓ Stay varies: from 1-2 months for climate treatment to 1-2 weeks for dental treatment, plastic surgery</li> <li>✓ Type and category of accommodation depends on the type of treatment – from sanatoriums to luxury hotels</li> <li>✓ Look for economic accommodation when longer length-of-stay required</li> </ul>
<i>Real estate buyers</i>	<ul style="list-style-type: none"> <li>✓ Stay 1-2 weeks</li> <li>✓ Might book accommodation in the area where they look for real estate</li> <li>✓ Book directly or via real estate agency</li> </ul>
<i>Music / Movie stars</i>	<ul style="list-style-type: none"> <li>✓ Length-of-stay depends on trip purpose – from 1 overnight for concerts to several months for film shooting</li> <li>✓ Luxurious accommodation in suites/apartments</li> <li>✓ Book a large number of rooms for accompanying persons</li> <li>✓ Use a lot of additional services</li> <li>✓ Low price elasticity</li> </ul>
<i>Tourists with pets</i>	<ul style="list-style-type: none"> <li>✓ Low price elasticity</li> <li>✓ Usually high willingness-to-pay</li> <li>✓ Low competition in the segment as not all hotels accept pets</li> <li>✓ Might have a long stay if pets participate in competitions</li> </ul>

“Note: adapted and expanded from Ivanov & Zhechev (2011)

**Table 6.2.** Revenue management characteristics of selected special events taking place at the hotel

Revenue management characteristics	Types of special events		
	Congresses	Conferences	Corporate meetings
<i>Number of participants</i>	300-2000+	100-500+	5-20+
<i>Length of stay (overnights)</i>	3-5	1-3	0-2
<i>Participants</i>	Members of associations, organisations, unions	Members of associations, organisations, unions	Employees of a company, its partners
<i>Type of participation</i>	Voluntary	Voluntary	Compulsory
<i>Planning period</i>	Over a year	Several months to more than a year	Several days, often same day
<i>Frequency</i>	Once a year or less often	Usually once a year but could be less or more frequent	Multiple times a year
<i>Financing of participation</i>	Participants cover part of their expenses	Participants cover part of their expenses	Costs covered entirely by the company
<i>Price elasticity of participants</i>	High	High	Low
<i>Additional revenues per participant</i>	Medium	Medium	High
<i>Repeat organisation of the event at the same hotel</i>	Very rare	Possible	Yes
	<i>Incentive trips</i>	<i>Seminars</i>	<i>Weddings</i>
<i>Number of participants</i>	10-30+	20-100+	Varies greatly: 20-2000+
<i>Length-of-stay (overnights)</i>	1-3	0-2	0-1
<i>Participants</i>	Employees of a company, its distributors	Employees of a company, its partners	The couple, relatives, friends
<i>Type of participation</i>	Voluntary	Mixed – voluntary and/or compulsory	Voluntary
<i>Planning period</i>	Several weeks	Several weeks	Several weeks to several months
<i>Frequency</i>	Usually once a year	Several times a year	Once for that couple
<i>Financing of participation</i>	Most expenses covered by the company	Expenses entirely or partially covered by the company	Costs most often covered by the couple/parents
<i>Price elasticity of participants</i>	Medium	Low	Varies, but usually low due to the purchase occasion
<i>Additional revenues per participant</i>	Low	Low	High
<i>Repeat organisation of the event in the same hotel</i>	Yes	Yes	No – for the same couple

*Note:* Adapted from Bowdin, Allen, O'Tole, Harris & MacDonnell (2006), Davidson & Rogers (2006), Ivanov & Zhechev (2011), Kotler, Bowen & Makens (2006), Shone & Parry (2004). The characteristics of the special events are exemplary. They may vary by country, year, organiser and should therefore be perceived only as indicative.

### Appendix 6.1. Segmentation criteria for tourists

Synthetic criteria	Analytic criteria	Sample segments
<i>Geographic</i>	Regions	<ul style="list-style-type: none"> <li>✓ Western / Central / Eastern Europe, etc.</li> <li>✓ Balkan countries / Scandinavia, etc.</li> </ul>
	Size of municipality/town/city	<ul style="list-style-type: none"> <li>✓ Less than 10000 inhabitants</li> <li>✓ 10001-50000</li> <li>✓ 50001-100000</li> <li>✓ 100001-200000</li> <li>✓ 200001-500000</li> <li>✓ over 500000</li> </ul>
	Climate of guest country of origin	<ul style="list-style-type: none"> <li>✓ Sub-tropical (Mediterranean)</li> <li>✓ Continental</li> <li>✓ Sub-polar</li> </ul>
<i>Demographic</i>	Age	<ul style="list-style-type: none"> <li>✓ Children below 12 years old</li> <li>✓ Teenagers 12-18 years old</li> <li>✓ 19-30</li> <li>✓ 31-45</li> <li>✓ 46-55</li> <li>✓ 56-65</li> <li>✓ Over 65 years old</li> </ul>
	Gender	<ul style="list-style-type: none"> <li>✓ Male</li> <li>✓ Female</li> </ul>
	Sexual orientation	<ul style="list-style-type: none"> <li>✓ Heterosexual</li> <li>✓ LGBT (lesbian, gay, bisexual, transsexual)</li> </ul>
	Family size	<ul style="list-style-type: none"> <li>✓ 1</li> <li>✓ 2</li> <li>✓ 3</li> <li>✓ 4</li> <li>✓ 5 or more family members</li> </ul>
	Family life cycle	<ul style="list-style-type: none"> <li>✓ unmarried</li> <li>✓ married without children</li> <li>✓ married with children below age 6</li> <li>✓ married with children between ages 7-12</li> <li>✓ married with children between ages 13-18</li> <li>✓ married without children below age 18</li> <li>✓ divorced without children</li> <li>✓ divorced with children between ages 6-12</li> <li>✓ divorced with children between ages 13-18 years old</li> <li>✓ divorced without children below age 18</li> <li>✓ widow / widower</li> </ul>
	Annual income (in euros)	<ul style="list-style-type: none"> <li>✓ below 10000 euros</li> <li>✓ 10001-25000 euros</li> <li>✓ 25001-50000 euros</li> <li>✓ 50001-100000 euros</li> <li>✓ Over 100000 euros</li> </ul>
	Profession	<ul style="list-style-type: none"> <li>✓ Various groupings possible</li> </ul>

<b>Synthetic criteria</b>	<b>Analytic criteria</b>	<b>Sample segments</b>
	Education	<ul style="list-style-type: none"> <li>✓ Without education</li> <li>✓ Primary</li> <li>✓ Secondary</li> <li>✓ Higher</li> </ul>
	Religion	<ul style="list-style-type: none"> <li>✓ Christian Orthodox</li> <li>✓ Christian Catholics</li> <li>✓ Christian Protestant</li> <li>✓ Muslims</li> <li>✓ Hebrews</li> <li>✓ Hinduists, etc.</li> </ul>
	Nationality	<ul style="list-style-type: none"> <li>✓ By country</li> </ul>
	Social class	<ul style="list-style-type: none"> <li>✓ Higher class</li> <li>✓ Upper middle class</li> <li>✓ Middle class</li> <li>✓ Lower middle class</li> <li>✓ Skilled working class</li> <li>✓ Working class</li> <li>✓ Subsistence</li> </ul>
<i>Psychographic</i>	Personality	<ul style="list-style-type: none"> <li>✓ Sporting personalities</li> <li>✓ Individualists</li> <li>✓ Gregarious</li> <li>✓ Ambitious</li> <li>✓ Authoritarian</li> <li>✓ Fashion followers</li> <li>✓ Trendsetters, etc.</li> </ul>
	Lifestyle	VALS framework: <ul style="list-style-type: none"> <li>✓ Innovators</li> <li>✓ Thinkers</li> <li>✓ Believers</li> <li>✓ Achievers</li> <li>✓ Strivers</li> <li>✓ Experiences</li> <li>✓ Makers</li> <li>✓ Survivors</li> </ul>
	Consumption lifestyle	<ul style="list-style-type: none"> <li>✓ Psychocentric</li> <li>✓ Allocentric</li> </ul>
<i>Behavioural</i>	Purchase occasion	<ul style="list-style-type: none"> <li>✓ Wedding</li> <li>✓ Birthday</li> <li>✓ Annual holiday, etc.</li> </ul>
	Benefits sought	<ul style="list-style-type: none"> <li>✓ Save money</li> <li>✓ High quality</li> <li>✓ Relaxation</li> <li>✓ Save time, etc.</li> </ul>
	Purchase readiness	<ul style="list-style-type: none"> <li>✓ Missing</li> <li>✓ Low</li> <li>✓ Medium</li> <li>✓ High</li> </ul>



Synthetic criteria	Analytic criteria	Sample segments
	Attitude toward the product	<ul style="list-style-type: none"> <li>✓ Positive</li> <li>✓ Neutral</li> <li>✓ Negative</li> </ul>
	Loyalty toward the brand	<ul style="list-style-type: none"> <li>✓ Low</li> <li>✓ Medium</li> <li>✓ High</li> </ul>
	Purchase volume (rooms)	<ul style="list-style-type: none"> <li>✓ 1-2 rooms</li> <li>✓ 3-5 rooms</li> <li>✓ 6-10 rooms</li> <li>✓ 11 and more rooms</li> </ul>
	Purchase volume (overnights)=length-of-stay	<ul style="list-style-type: none"> <li>✓ 1 overnight</li> <li>✓ 2-3 overnights</li> <li>✓ 4-6 overnights</li> <li>✓ 7 and more overnights</li> </ul>
	Booking mode	<ul style="list-style-type: none"> <li>✓ Direct</li> <li>✓ Hotel chain website</li> <li>✓ Tour operator</li> <li>✓ Travel agent</li> </ul>
	Lead period	<ul style="list-style-type: none"> <li>✓ Without a booking</li> <li>✓ Booking made on the day of check-in</li> <li>✓ Booking made one day before check-in</li> <li>✓ Booking made 2-6 days before check -in</li> <li>✓ Booking made 7-13 days before check-in</li> <li>✓ Booking made 14-27 days before check-in</li> <li>✓ Booking made 28 or more days before check-in</li> </ul>
<i>Technical and organisational characteristics of the trip</i>	Group size	<ul style="list-style-type: none"> <li>✓ Individual trip</li> <li>✓ Group trip (6 and more travellers)</li> </ul>
	Transportation mode	<ul style="list-style-type: none"> <li>✓ Car / Bus</li> <li>✓ Flight</li> <li>✓ Water</li> <li>✓ Rail</li> </ul>
	Period of travel	<ul style="list-style-type: none"> <li>✓ Weekday / weekend day</li> <li>✓ Month of the year</li> </ul>
<i>Travel motives</i>	Travel motives	<ul style="list-style-type: none"> <li>✓ Holiday</li> <li>✓ Business</li> <li>✓ Medical treatment</li> <li>✓ Education</li> <li>✓ Shopping</li> <li>✓ Religion</li> <li>✓ Visiting friends and relatives, etc.</li> </ul>

*Note:* Summarised and adapted from Bowie & Buttle (2011), Hsu, Kang & Wolfe (2002), Ivanov & Zhechev (2011), Kim, Park, Gazzoli & Sheng (2011), Kotler, Bowen & Makens (2006), Kotler, Keller, Brady, Goodmand, Hansen (2009), Plog (2001), Rakadzhiiska, Marinov & Dyankov (2013), Sarigollu & Huang (2005), Scott & Parfitt (2004), Shoemaker (1994), Strategic Business Insights (2013), Thyne, Davies & Nash (2004), Tranter, Stuart-Hill & Parker (2008), Wearne & Morrison (2011).

**Appendix 6.2. Segmentation criteria for organisational customers**

<b>Synthetic criteria</b>	<b>Analytic criteria</b>	<b>Sample segments</b>
<i>Economic</i>	Type of industry	<ul style="list-style-type: none"> <li>✓ Government and municipal institutions</li> <li>✓ Construction companies</li> <li>✓ Pharmaceutical companies, etc.</li> </ul>
	Size of organisation	<ul style="list-style-type: none"> <li>✓ Micro</li> <li>✓ Small</li> <li>✓ Medium-sized</li> <li>✓ Large corporations/organisations</li> </ul>
	Location	<ul style="list-style-type: none"> <li>✓ Location by city/region/country</li> </ul>
<i>Behavioural</i>	Purchase (hotel selection) criteria	<ul style="list-style-type: none"> <li>✓ Location</li> <li>✓ Lowest price</li> <li>✓ High quality</li> <li>✓ Optimal price/quality ratio</li> <li>✓ Possibility for booking amendment</li> <li>✓ Available additional services</li> <li>✓ Chain affiliation</li> </ul>
	Previous use of hotel services	<ul style="list-style-type: none"> <li>✓ Yes</li> <li>✓ No</li> </ul>
	Loyalty	<ul style="list-style-type: none"> <li>✓ Low</li> <li>✓ Medium</li> <li>✓ High</li> </ul>
<i>Situational</i>	Travel motives	<ul style="list-style-type: none"> <li>✓ Business trip</li> <li>✓ Participation in special event</li> <li>✓ Corporate training</li> <li>✓ Teambuilding, etc.</li> </ul>
	Group size	<ul style="list-style-type: none"> <li>✓ Individual trip</li> <li>✓ Group trip (6 and more travellers) – conventions, association meetings, corporate meetings, SMERFs</li> </ul>
	Transportation mode	<ul style="list-style-type: none"> <li>✓ Car / Bus</li> <li>✓ Flight</li> <li>✓ Water</li> <li>✓ Rail</li> </ul>
	Purchase volume (rooms)	<ul style="list-style-type: none"> <li>✓ 1-2 rooms</li> <li>✓ 3-5 rooms</li> <li>✓ 6-10 rooms</li> <li>✓ 11 and more rooms</li> </ul>
	Purchase volume (overnights)=length-of-stay	<ul style="list-style-type: none"> <li>✓ 1 overnight</li> <li>✓ 2-3 overnights</li> <li>✓ 4-6 overnights</li> <li>✓ 7 and more overnights</li> </ul>
	Purchase volume (services used)	<ul style="list-style-type: none"> <li>✓ Only accommodation</li> <li>✓ Only additional services (no guest rooms)</li> <li>✓ Accommodation and additional services</li> </ul>

*Note:* adapted from Ivanov and Zhechev (2011) and expanded on the basis of Kotler, Bowen & Makens (2006), Swarbrooke & Horner (2001), Tranter, Stuart-Hill & Parker (2008).

## Chapter 7

### INFORMATION PROVISION FOR THE REVENUE MANAGEMENT PROCESS

A good revenue management decision is an informed decision. As discussed in Chapters 3 and 4 the revenue manager needs very detailed data on various statistics in order to make a justified decision which are provided by the hotel's marketing information system. Kotler *et al.* (2009: 173) define the marketing information system as the set of "people, equipment and procedures to gather, sort, analyse, evaluate and distribute needed, timely and accurate information to marketing decision makers". Similar to market segmentation, the marketing information system has been widely discussed in the literature (Ivanov & Zhechev 2011; Kotler *et al.* 2009; Kotler, Bowen & Makens, 2006); that's why this book reflects only those issues related to the hotel revenue management.

The revenue manager will base his decisions on data about hotel's internal (operations), micro- (customers, competitors, distributors) and macroenvironment (PESTEL factors). Table 7.1 below summaries the revenue management related statistics and the sources for their provision by data dimension. The statistics and sources included in Table 7.1 are not comprehensive and should be considered only as indicative. In practice the revenue manager could use more statistics from a greater variety of sources. The revenue management metrics discussed in Chapter 5 are not included in Table 7.1 because they are *composite* metrics calculated with the help of the operational data provided by the marketing information system. Revenue management data should fulfill the following requirements:

- ✓ *Accuracy* – the data reflect truly the real situation.
- ✓ *Timeliness* – the data are provided when necessary.
- ✓ *Sufficiency* – the provided data should be detailed enough for the revenue manager to make an informed decision – not too few as no in-depth analysis is possible and not too much because it may lead to information overload.

✓ *Inexpensive to obtain* –costly data are justifiable for use only if they greatly increase accuracy of forecasts and quality of the revenue management decisions.

**Table 7.1.** *Information provision for the revenue management process – dimensions, statistics, sources*

<b>Dimensions</b>	<b>Revenue management related statistics</b>	<b>Source</b>
<i>Operational data</i>	<ul style="list-style-type: none"> <li>✓ Number of bookings for a particular date (total, by distribution channel/room type/segment)</li> <li>✓ Number of bookings at a particular date (total, by date, by distribution channel/room type/segment)</li> <li>✓ Length-of-stay (average, by distribution channel/room type/segment)</li> <li>✓ Prices (average, by distribution channel/room type/segment)</li> <li>✓ Lead period (average, by distribution channel/room type/segment)</li> <li>✓ Number of cancellations of confirmed bookings (average, by distribution channel/room type/segment)</li> <li>✓ Number of booking requests for a particular date</li> <li>✓ Number of rooms per booking (average, by distribution channel/room type/segment)</li> <li>✓ No-shows, walk-ins and denials (by date, distribution channel/room type/segment)</li> <li>✓ Consumption of additional services – by type/period/segment</li> <li>✓ Repeat visits by customers</li> <li>✓ Demographic characteristics of guests – age, gender, nationality, etc.</li> <li>✓ Variable costs per overnight/roomnight</li> <li>✓ Website analytics (visits to the website by country, page, device, referring website, etc.)</li> </ul>	<ul style="list-style-type: none"> <li>✓ Property management system/revenue management software of the hotel</li> <li>✓ Website of the hotel (chain)</li> <li>✓ Accounting documentation of the hotel (chain)</li> <li>✓ Google Analytics data for the website of the hotel (chain)</li> <li>✓ Ad hoc marketing research</li> </ul>
<i>Customers</i>	<ul style="list-style-type: none"> <li>✓ Size and sales volume</li> <li>✓ Hotel selection criteria – location, price, quality, price-quality ratio, availability of specific facilities, brand affiliation, etc.</li> <li>✓ Degree of loyalty to hotel chain brands</li> <li>✓ Demographic characteristics of market</li> </ul>	<ul style="list-style-type: none"> <li>✓ Reports, datasets and publications by international organisations (UNWTO, OECD, UNO, Eurostat, WTTC, IATA, etc.)</li> <li>✓ Reports, datasets and publications by government authorities and national statistics institutes</li> </ul>

Dimensions	Revenue management related statistics	Source
	<ul style="list-style-type: none"> <li>segments</li> <li>✓ Booking characteristics – lead period, length-of-stay, group size, travel period</li> <li>✓ Price elasticity and willingness-to-pay by segment</li> <li>✓ Preferred distribution channels</li> </ul>	<ul style="list-style-type: none"> <li>✓ Reports, datasets and publications by national, regional and local tourism organisations (destination marketing organisations, convention and visitors bureaus, tourism boards, tourism councils, associations, etc.)</li> </ul>
<i>Competitors</i>	<ul style="list-style-type: none"> <li>✓ Size and sales volume</li> <li>✓ Category, location, offered services</li> <li>✓ Prices and booking terms</li> <li>✓ Market positioning</li> <li>✓ Distribution channels used</li> <li>✓ Current promotions</li> </ul>	<ul style="list-style-type: none"> <li>✓ Hospitality industry reports (<i>Keynote, Intel, Euromonitor, Datamonitor</i>)</li> <li>✓ Websites of competitors, distributors and customers</li> <li>✓ Social media pages/profiles of competitors, distributors and customers (<i>Facebook, Twitter, Google+, LinkedIn, Foursquare, YouTube, TripAdvisor, etc.</i>)</li> </ul>
<i>Distributors</i>	<ul style="list-style-type: none"> <li>✓ Business model – merchant or agency</li> <li>✓ Levels of commissions/mark-ups</li> <li>✓ Number and geographic coverage of hotels on their websites</li> <li>✓ Size and sales volume</li> <li>✓ Number of offices</li> <li>✓ Geographic distribution of customers</li> <li>✓ Market positioning</li> <li>✓ Current promotions</li> </ul>	<ul style="list-style-type: none"> <li>✓ Annual financial statements of competitors and distributors</li> <li>✓ Meta search engines (<i>Kayak.com, Hotelscombined.com, Trivago.com, etc.</i>)</li> <li>✓ Visits to the office of the distributor or the customers, to the competing hotels</li> </ul>
<i>Macroenvironment (PESTEL factors)</i>	<ul style="list-style-type: none"> <li>Trends, developments and statistical data on different factors:</li> <li>✓ Political</li> <li>✓ Economic</li> <li>✓ Socio-cultural and demographic</li> <li>✓ Technological</li> <li>✓ Environmental</li> <li>✓ Legal</li> </ul>	<ul style="list-style-type: none"> <li>✓ Advertisements of competitors and distributors</li> <li>✓ Travel fairs (e.g. ITB-Berlin, World Travel Market-London, etc.)</li> <li>✓ Blogs, forums, technology reports</li> <li>✓ Consulting companies' bulletins</li> <li>✓ Academic publications</li> <li>✓ Trade press publications</li> <li>✓ Legislation databases</li> <li>✓ Ad hoc marketing research</li> </ul>

Data may be obtained from different sources. The internal accounting system of the hotel (chain) and its property and revenue management software are the primary sources of operational data. Mostly operational data are either readily available or easy to obtain/calculate. They are also visualised by the RM software through the use of appropriate graphs (e.g. the booking curves to be discussed in the next Chapter 8) which facilitate the decision-making process. It is important that all bookings and purchases of guests are registered in the internal database of the hotel in a timely manner so that the revenue manager and the managers of different revenue centres in the hotel have real-time information about the financial and operational statistics for their respective departments which will allow them to make relevant managerial

decisions. This requires the hotel to have an elaborate property and revenue management system that integrates all departments and assures real-time connectivity with its website and all POS terminals in the hotel. The use of QR codes and RFID tags/chips could facilitate the automatic entry and reading of data into/from the information system.

Information sources on customers, distributors, competitors and the macroenvironment are very diverse in terms of type and characteristics. They vary from free (e.g. most of the statistical data by the national statistics institutes) to paid (e.g. Mintel industry reports), from highly academic (articles in academic journals) to very pragmatic (articles in the trade press), from very general (publications by international organisations) to very specific (websites of competitors), from sources of quantitative data (statistical websites) to qualitative evaluations (blogs). Websites of competitors and distributors and their social media profiles are an invaluable source of information regarding their prices, market positioning strategies, current promotions, etc. Travel fairs are an excellent opportunity for the hotel (chain) to stay current with the latest developments in the industry.

Some additional points need to be considered in terms of data collection. First, the external sources of information should be assessed for their *credibility*. Official data by national statistics institutes and international organisations, industry reports (by Mintel, Keynote, Euromonitor, Datamonitor) and academic publications are usually considered to be of highest credibility due to their systematic scientific research approach to data collection, analysis and interpretation. Blogs and forums, in this regard, have the lowest credibility but are a good source of information for current trends in the industry. Second, if information is not obtainable via internal or external sources or if it is not detailed enough or entirely relevant, the revenue manager may undertake or commission a *marketing research* (Zikmund & Babin, 2013) and social media could be actively used in the data collection process (Illum, Ivanov, Liang, 2010). Finally, the revenue manager is advised to apply *triangulation* if this is financially feasible, i.e. to try obtaining one and the same piece of information from different sources to be sure of its reliability and credibility. In any case, the quality of the revenue management decisions will depend on the quality of the data and information generated by the hotel marketing information system.

## Chapter 8

### REVENUE MANAGEMENT ANALYSIS

#### 8.1. Levels of analysis

Analysis of data for operations, customers, competitors, distributors and the macroenvironment is implemented on three levels: strategic, tactical and operational (Figure 8.1). Results from the analysis are used in forecasting which, on the other hand, is a necessary prerequisite for effective revenue management decisions.

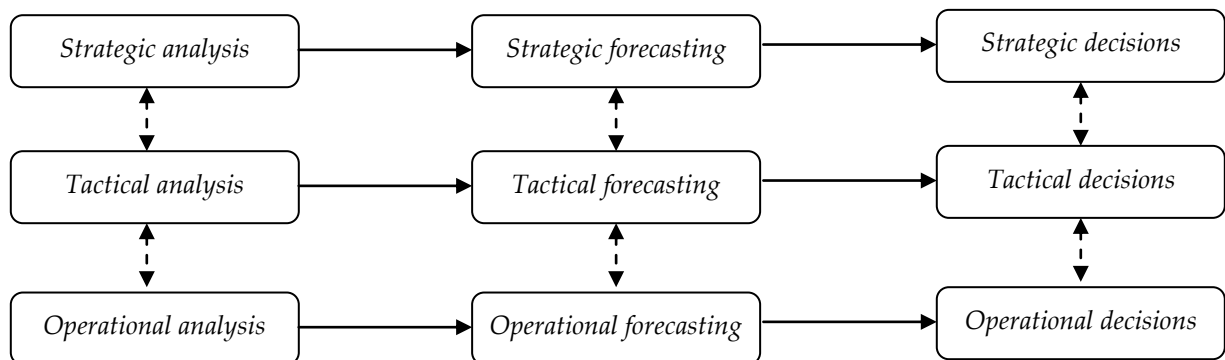

**Figure 8.1.** Relationships among the levels of revenue management analysis, forecasting and decisions

**Strategic analysis** is implemented once or more times a year and concentrates on the 'big picture'. It includes:

- ✓ *SWOT analysis of the destination* – identification of the strengths, weaknesses, opportunities and threats to the destination in terms of accessibility, tourist resources, image, etc. It is important because tourists first select the destination and then the hotel. Changes in destination's accessibility (available number of seats in flights per week, changes in direct flights, opening of a new highway) would have direct implications on the number of tourists that could physically travel to the destination and, therefore, on hotel accommodation demand. Some city hotels in Varna, Bulgaria,

for example, experienced more than a 15% annual increase in their occupancy rates in 2005 and 2006 compared to 2003 and 2004 after the opening of direct flights from Budapest to Varna in June 2004 by Malev Airlines and from Vienna in 2005 by Austrian Airlines (personal communication by the author with hotel managers in Varna, Bulgaria). Before these direct links were established, Varna was accessible only by direct charter flights in the summer and regular scheduled flights via the country's capital, Sofia. Increased accessibility of the destination attracted more tourists during the non-summer months. Furthermore, the development of more man-made tourist attractions (e.g. amusement parks) or archaeological discoveries may also influence positively the demand to the destination.

✓ *Tourism demand to the destination* should be analysed in terms of volume (number of arrivals/roomnights/overnights), spending (total revenues from tourism, average spending per tourist), structure (by gender, nationality, transportation mode, consumption lifestyle and other segmentation criteria from Table 6.1.) and seasonality. Analysis of demand would reveal the trends in arrivals, average spending per tourist, seasonal patterns in tourist arrivals, and other tendencies that shape demand for the product of the hotel. Changes in the prevailing segments coming to the destination might be finding the hotel unprepared. Bulgarian seaside resorts, for example, until the 1990s targeted mostly Western European charter markets – tourists arrived at the destination by flight, transfers from/to the airport were provided by bus which did not stay at the hotel. This eliminated the necessity for hotels to have large parking areas. After Bulgaria's entry into the European Union in January 2007, many seaside hotels and resorts in the country heavily targeted the Romanian market and the number of arrivals from Romania increased threefold in just five years – from 612630 visitors in 2004 to 1769194 in 2008 (NSI, 2013a). However, Romanian tourists arrived in the country by car, not by plane or bus, which increased dramatically the demand for parking lots – something the seaside resorts in Bulgaria found difficult to provide. Parking has now been transformed into a selling proposition and competitive advantage for hotels for this market segment.

✓ *Room supply at the destination* must be analysed on several levels – dynamics of total room supply (construction of new properties, closing or change of the capacity of existing ones) and structure by type and category of accommodation establishments. Room supply, its type and category structure determines the competition at the destination. Usually the increase in room supply is negatively evaluated by existing hotels because it increases the competitive rivalry for guests.



However, successful marketing of a specific type of hotel product might require a critical mass of tourist development and room supply. A single casino hotel cannot create a casino destination – there should be several such (competing) hotels in order the destination to be able to attract a significant enough number of tourists whose primary motive is gambling. Otherwise a casino will just be an additional entertainment service provided to hotel guests whose primary travel motive is other than gambling. Development of Las Vegas, Nevada with its 150,481 room inventory in 2012, 39727022 visitors, 9.4 billion USD gambling revenues, and occupancy rates consistently higher than 80% (LVCVA, 2013) is a good example of this direction. Type and category structure of accommodation establishments shape the image of the destination and the market segments it will attract – prevailing campsites and 2-3-star hotels will create an image of a cheap destination, thus depressing the prices at the 5-star properties in the destination.

✓ *SWOT analysis of the hotel* focuses on its strengths, weaknesses, opportunities and threats. Strengths and weaknesses stem from its internal environment (location, product, pricing, distribution, positioning, image, cost structure, financial management, human resources) while the opportunities and threats stem from its external environment (macro- and microenvironment). The revenue manager must be familiar with the strengths of the hotel in order to capitalise on them as well as its weaknesses so their negative consequences are mitigated or even transformed into a competitive advantage. A hotel in a seaside resort located far from the beach could target market segments that value tranquillity and relaxation while a hotel on the promenade would charge premium prices for its sea-view rooms.

✓ *Strategic analysis of the revenue management metrics of the hotel* – its goal is to evaluate the long-term dynamics of RevPAR, ADR, occupancy, GOPPAR and the other RM metrics, and to identify the factors that influence them. Multivariate regression analysis could reveal the relationship between the dynamics of the RM metrics and a number of explanatory variables – room supply at the destination, arrivals, hotel's prices, competitors' prices, special events organised in the destination and/or the hotel, etc. Results of this analysis will be then used to fuel the forecasts of the RM metrics.

The time scale of the **tactical analysis** is up to one year. It looks at short-term changes in room supply and tourism demand, competitors' pricing, commissions and booking terms (release periods, cancellation deadlines, payment terms), seasonality of

demand, booking patterns (lead period, travel period), short-term dynamics of the RM metrics, etc. The goal is to identify short-term trends, market opportunities, evaluation of the efficiency of different distribution channels. For seasonal hotels tactical analysis might reveal, for instance, that bookings for the main tourist season for the current year are accruing faster and earlier than in the previous year which gives ground for higher prices and less use of promotional rates. The analysis might also show that a particular tour operator utilised only 40% of its allotment during the year, which could serve as a reason to decrease it for the subsequent season/year. A special case of the tactical analysis would be the annual review of the revenue management process in the hotel (chain) – review of the RM decisions made during the year and their impact on the dynamics of the RM metrics.

**Operational analysis** has the shortest time horizon – days or weeks. At this level of analysis, room supply is constant so the analysis focuses mostly on competitors' prices, demand, daily/weekly changes in RM metrics. It is performed daily and weekly by the revenue manager/night auditor and discussed with the general manager, the front office and managers of the other revenue generating centres of the hotel. This analysis is the basis for opening/closing of dates for sale, opening/closing of price levels, changes in the OTAs' allotments (e.g. on *Booking.com*) and overbooking levels, or last-minute promotions.

Strategic, tactical and operational analyses are interconnected. Figure 8.2 illustrates sample hypothetical curves of the RevPAR dynamic on the three levels. Strategic analysis reveals the trend in annual RevPAR, tactical analysis – the monthly RevPAR seasonal dynamic while operational analysis – the daily RevPAR. Each level could be perceived as a closer 'zoom' in the upper level of the analysis (the circle with the dashed lines in *b*) and *c*)), or as an aggregation of the preceding lower level.

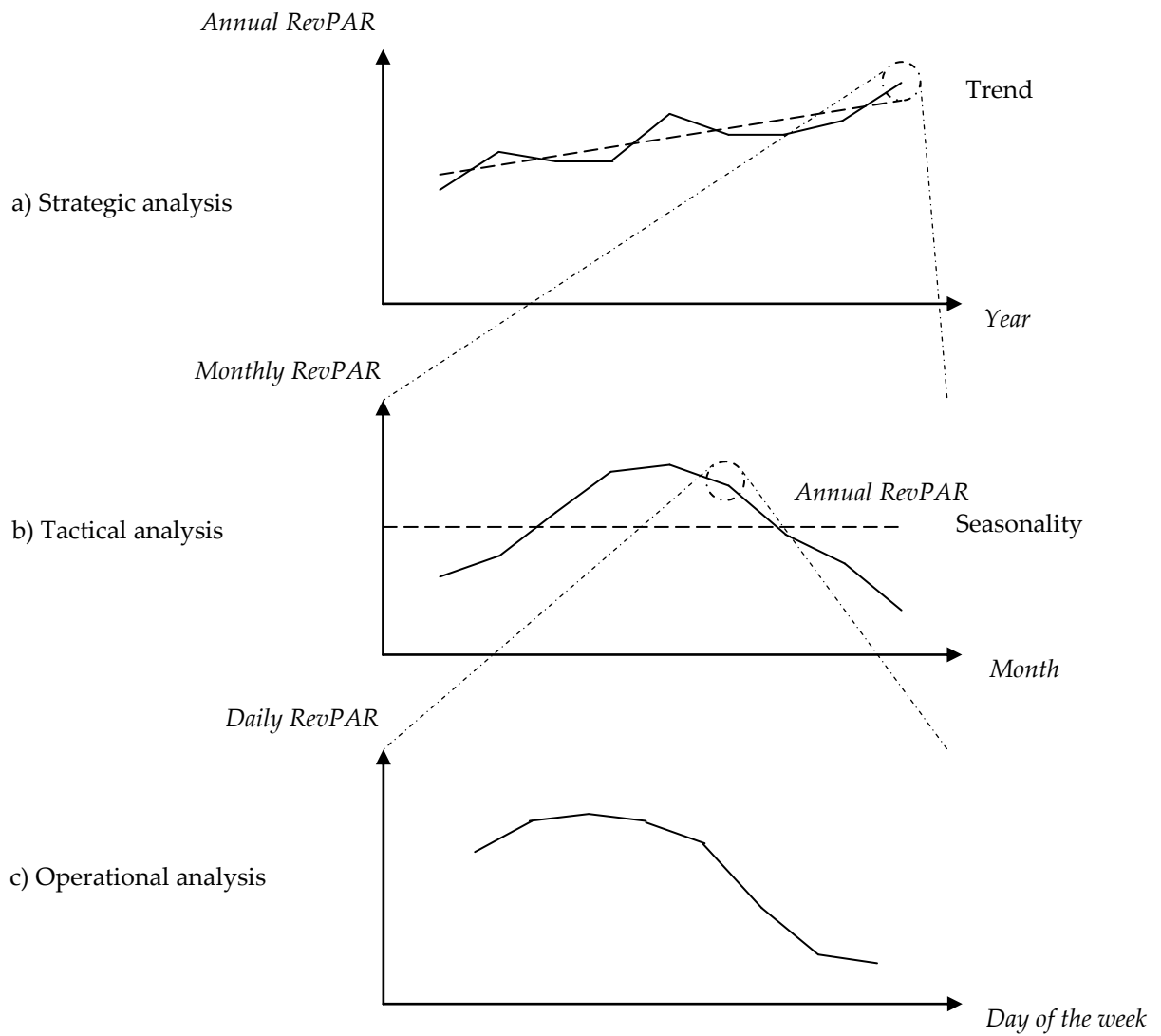

**Figure 8.2.** Relationship between strategic, tactical and operational analyses

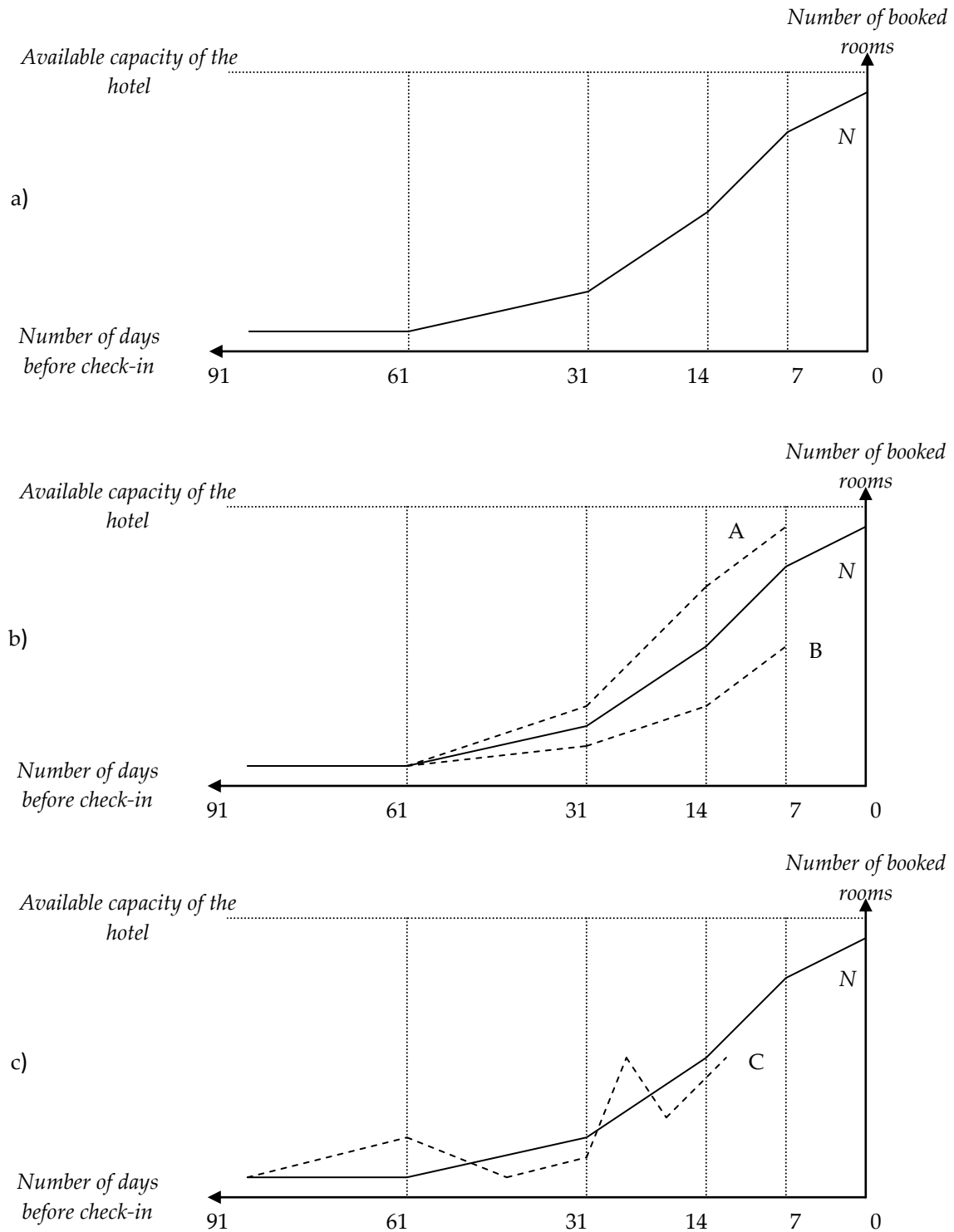

**Figure 8.3.** Booking curve for a particular check-in date

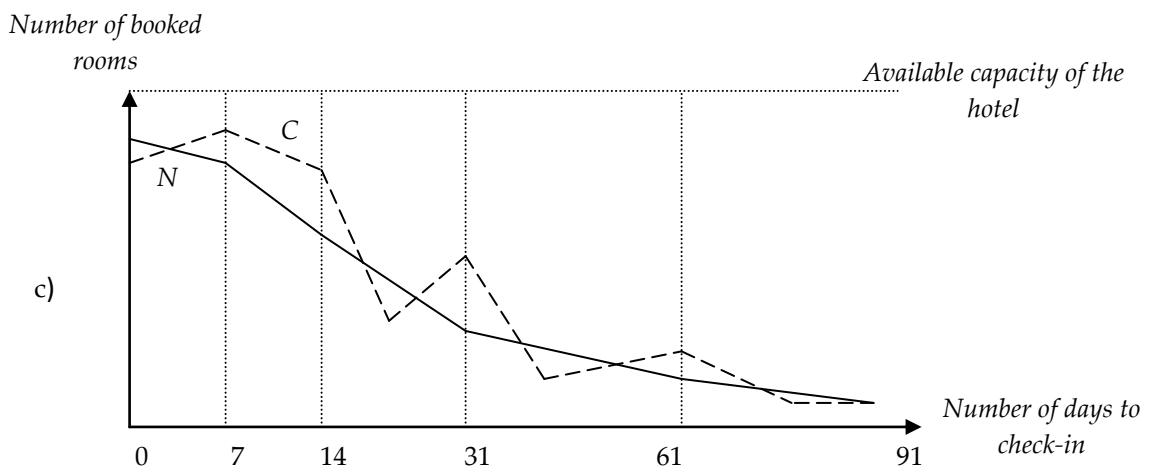
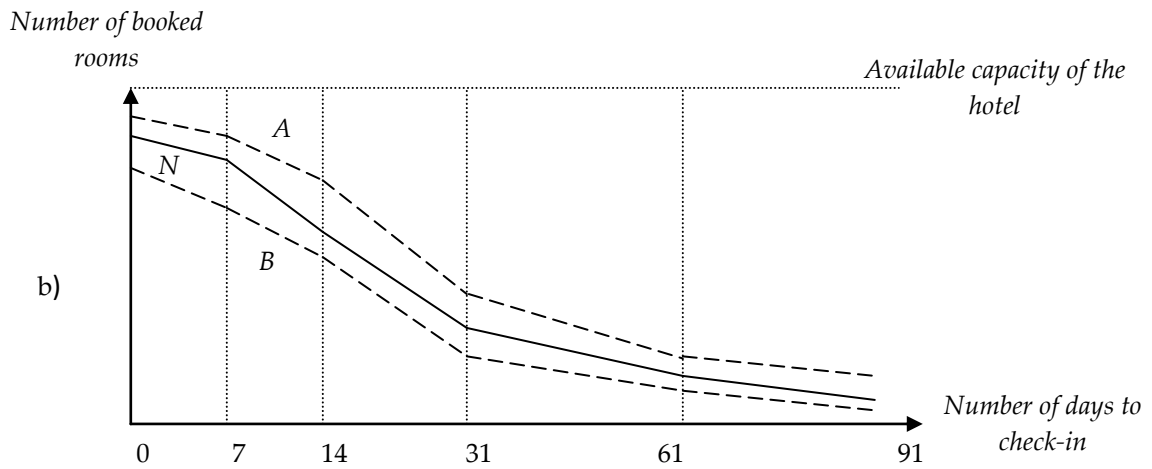
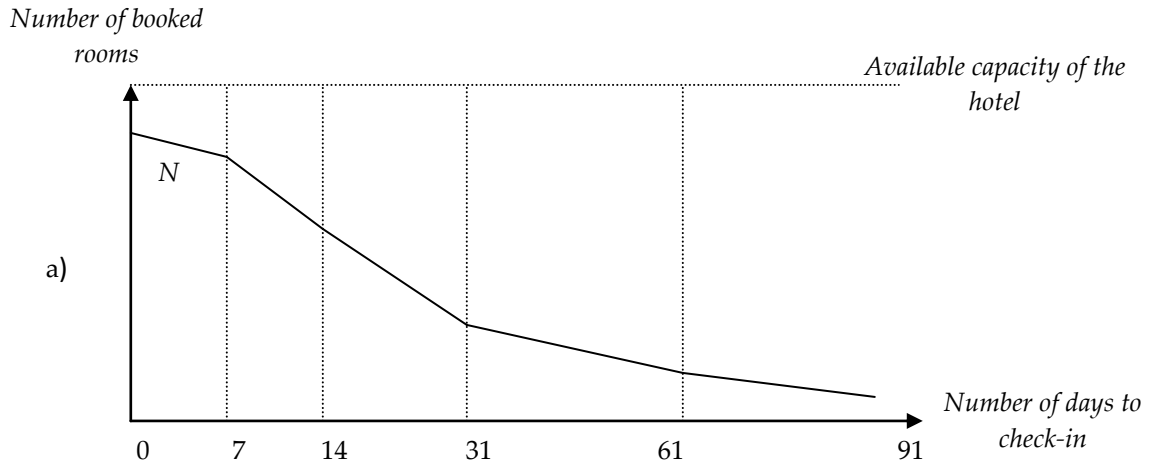

**Figure 8.4.** Booking curve at a particular date

## 8.2. Analytical tools

One of the most useful instruments for operational analysis is the **booking curve** (Figures 8.2. and 8.3.) (see also Queenan *et al.*, 2007). It can be prepared for a particular check-in date (Figure 8.3.) and illustrates the booking pace (Coleman, 2014), i.e. how bookings accrue for that particular date. The exemplar booking curve on Figure 8.3a shows that 91 days before check-in, less than 10% of the rooms for that date have been booked, 31 days before check-in – 25%, 14 days before check-in – 50%, and so on. The faster bookings accrue the better for the hotel because the uncertainty of the sales and occupancy rate decreases, although confirming too many rooms too early will limit hotel's opportunities to accept future more profitable booking requests. However, looking only at the curve in Figure 8.3a, one cannot conclude that the booking pace is slow, normal or high – one has to compare the booking curve for a particular date with the booking curve for the same date in the previous year (Figure 8.3b). If the booking curve for a particular date for the current year is below the curve for the same date in the previous year (curve *A* vs. curve *N* on Figure 8.3b), the hotel is performing worse than the previous year when bookings were accruing faster. In this situation the revenue manager might consider opening the lower price levels. Of course, the revenue manager should also take into account the differences in the day of the week the date was in the previous year, and is in the current year. If the date was a Thursday last year but a Friday this year, this would make a significant difference for the occupancy rate in a business hotel. In this case it would be better to compare the booking curve for the particular check-in date with the booking curve for the same day of the week in previous year, i.e. in our example to compare it with the curve for Friday (same day of the week) not Thursday (same date). Special events that took place in the previous year (e.g. Olympic Games, exhibitions, etc.) but are not being held in the current one should also be considered as they drive booking curves upward. Comparison with the booking curve from previous year might reveal a reverse situation – this year bookings are arriving earlier (curve *B* vs. curve *N* on Figure 8.3b), i.e. the hotel is performing well and no promotions are needed for the moment to stimulate the demand. Of course, the booking curves on Figures 8.3a and 8.3b are ideal versions – in practice a booking curve will look more like curve *C* on Figure 8.3c – sometimes it is ascending (bookings received) and sometimes is descending (bookings cancelled).

Figure 8.4 depicts a different perspective of the booking curves – booking curve at a particular date. It illustrates how many booked rooms the hotel has received up to a particular moment for various dates in the future. Similar to the previous type, the booking curve at a particular date for the current year must be compared with the same curve for the previous year (Figure 8.4.b). If the current curve is above the curve from the previous year (curve *B* vs. curve *N*) the hotel has received up to this date more bookings for future dates than last year, i.e. it is performing better. To the contrary, if the current curve *N* is below the previous year's curve *A* the revenue manager should pay attention to the reasons and undertake necessary actions. In practice, this booking curve would look more like curve *C* (Figure 8.4c) – more rooms booked for some dates, less for others.

The two booking curves are conceptually different. The booking curve for a particular check-in date (Figure 8.3) shows the dynamics of booked rooms for that check-in date, while the booking curve at a particular date (Figure 8.4) shows the future bookings the hotel has received so far to this date. Nevertheless, both types of curves could be used to analyse customers' booking behaviour – how many days in advance before check-in they make a booking at the hotel, i.e. the booking lead time. This provides information about the timing of promotions. Looking at curve *N* on Figure 8.3 we could definitely say that offering a promotional rate more than 91 days (3 months) before the check-in date would not be reasonable as it is too early – it might not be noticed and would not have significant impact on bookings. It would be better if the hotel times the promotion 14-45 days before the check-in date – not too early so it would be noticed by potential customers and not too late in order to allow them to use the promotion. Of course, the hotel might use a more rigorous pricing schedule and offer special prices for early bookings made a certain minimum number of days before check-in (so called 'early bird' rates), but they would be considered as part of hotel's regular pricing strategy rather than as promotions.

## Chapter 9

### REVENUE MANAGEMENT FORECASTING

#### *9.1. Overview of revenue management forecasting*

Forecasting is a key stage in the revenue management process as forecasts feed and determine the decision-making process (Figure 8.1). Therefore, a high proportion of the related research literature is dedicated to forecasting from a theoretical and methodological perspective (Burger *et al.*, 2001; Frechtling, 2001; Tranter, Stuart-Hill & Parker, 2008; Weatherford, Kimes & Scott, 2001; Weatherford & Kimes, 2003, among others), summarised in Table 9.1. Review of available literature on hotel revenue management reveals that most studies have dealt with two main topics: forecasting demand (e.g. Frechtling, 2001; Lim & Chan, 2011; Song, Witt & Li, 2009) and forecasting RM metrics and operational data (El Gayar *et al.*, 2011; Haensel & Koole, 2011; Morales & Wang, 2010; Zakhary *et al.*, 2011). This is justified since volume, structure and characteristics of demand and forecasts for occupancy rate, number of arrivals, cancellations, no shows, RevPAR, ADR and other operational statistics are of utmost importance to a hotel's revenue management system. However, revenue management decisions in a particular hotel are influenced by its competitors' decisions and actions and the developments in the external macro- and micro environment (see the impacts on the RM system on Figure 3.1). Therefore it is surprising that a limited number of papers, most notably Yüksel (2007), discuss issues related to forecasting competitive actions and the external environment which remains a neglected field of study.

#### *9.2. Levels of forecasting*

Forecasting is based on the results of the revenue management analysis. That's why we distinguish the same levels of forecasting as in the analysis – strategic, tactical and operational forecasting as depicted in Figure 8.1. On the other hand, forecasts help revenue managers make decisions on the same respective levels.



**Table 9.1.** Forecasting – review of selected papers

Research topic		Selected papers	
General theoretical and methodological issues in forecasting		Burger <i>et al.</i> (2001); Chen & Kachani (2007); Frechtling (2001); Nash & Nash (2001); Song, Witt & Li (2009); Tranter, Stuart-Hill & Parker (2008); Weatherford, Kimes & Scott (2001); Weatherford & Kimes (2003)	
Application of forecasting methods	Modelling and forecasting demand	Chen & Kachani (2007); Frechtling (2001); Law (2000); Lim & Chan (2011); Liu, Smith, Orkin & Carey (2002); Ng, Maull & Godsiff (2008); Nowman & van Dellen (2012); Onafowora & Owoye (2012); Pan, Wu & Song (2012); Rajopadhye <i>et al.</i> (2001); Song & Li (2008); Song, Witt & Li (2009); Vergori (2012); Yüksel (2007)	
	Forecasting competition and the external environment	Yüksel (2007)	
	Forecasting revenue management metrics and operational data (arrivals, cancellations, no shows, amendments, prices, etc.)	Brannas, Hellstrom, & Nordstrom (2002); El Gayar <i>et al.</i> (2011); Haensel & Koole (2011); Kimes (1999a); Morales & Wang (2010); Wu, Hsiao & Tsai (2008); Zakhary <i>et al.</i> (2011)	
Forecasting method applied (analysed)	Historical (time series)	Random walk (naïve)	Burger <i>et al.</i> (2001)
		Moving average	Burger <i>et al.</i> (2001); Weatherford & Kimes (2003); Yüksel (2007)
		Exponential smoothing	Burger <i>et al.</i> (2001); Chen & Kachani (2007); Rajopadhye <i>et al.</i> (2001); Weatherford & Kimes (2003); Yüksel (2007)
		Other autoregressive models (Box-Jenkins, ARMA, ARIMA, SARIMA, etc.)	Burger <i>et al.</i> (2001); Lim & Chan (2011); Lim, Chang & McAleer (2009); Nowman & van Dellen (2012); Onafowora & Owoye (2012); Pan, Wu & Song (2012); Vergori (2012); Yüksel (2007)
	Advanced booking	Additive (classical and advanced pickup)	Chen & Kachani (2007); Phumchusri & Mongkolkul (2012); Weatherford & Kimes (2003); Zakhary, El Gayar & Atiya (2008)
		Multiplicative	Phumchusri & Mongkolkul (2012); Weatherford & Kimes (2003); Zakhary, El Gayar & Atiya (2008)
	Combined	Regression	Burger <i>et al.</i> (2001); Chen & Kachani (2007); Weatherford & Kimes (2003)
		Combination of historical and advanced booking	Chen & Kachani (2007)
		Artificial neural networks	Burger <i>et al.</i> (2001); Law (2000); Padhi & Aggarwal (2011); Palmer, Montaña, & Sesé (2006); Zakhary, El Gayar & Ahmed (2010)
	Qualitative methods	Delphi	Yüksel (2007)

Source: adapted from Ivanov & Zhechev (2012) and expanded by the author

**Strategic forecasting** in the revenue management process includes forecasting the long-term dynamic of the following:

- ✓ *Demand* to the destination – number of arrivals and overnights, tourists' expenses (total and for accommodation), preferences, etc.
- ✓ *Room supply* at the destination – number of rooms, changes in room/bed capacity of the destination, changes in the structure of room/bed capacity by category and type of accommodation establishment.
- ✓ *Destination's attractiveness and accessibility* – changes in transport connections to the destination, opening/closing of major tourists resources driving tourism demand to the destination (theme park, convention centre, enterprise, pilgrimage centre, etc.), destination image.
- ✓ *Strategic forecasts of the revenue management metrics of the hotel* – RevPAR, ADR, occupancy, GOPPAR and other RM metrics used by the revenue manager.

The goal of strategic forecasting is to predict long-term competitiveness of the destination as a whole to attract and serve tourists rather than dealing with forecasts at property level. The reason is clear – if in the long run the destination as a whole is not competitive, it will be entering its decline stage and facing a decreasing number of arrivals and tourist expenditures, the revenue manager cannot hope that his hotel will be attracting more guests who will generate higher revenues at higher prices.

**Tactical forecasting** deals with forecasting the volume of demand to the particular hotel, demand structure by segments (see Tables 6.1 and 6.2) and distribution channel, occupancy, price levels, length-of-stay, competitors' prices and actions, distributor's behaviour, etc. The aim is to identify future periods with potential high and low demand in order to take necessary actions – avoid confirming low contribution group bookings for periods with high demand and stimulate demand during slow periods.

**Operational forecasting** has the shortest time horizon – several days up to a month ahead. Its final result is a forecast about the revenue management metrics (mostly ADR and occupancy) of the hotel by date, room type, market segment and distribution channel. Operational forecasts will reveal the need to use last minute promotions in order to attract guests.

## 9.2. Forecasting methods

Forecasting involves the application of different quantitative and qualitative methods to provide the revenue manager with prognoses about the future development of RM metrics, demand and supply. Weatherford & Kimes (2003) divide quantitative methods into historical, advanced booking and combined methods. Mostly used (or analysed) by researchers historical methods include: moving average (Burger *et al.*, 2001; Weatherford & Kimes, 2003; Yüksel, 2007), exponential smoothing (Burger *et al.*, 2001; Chen & Kachani, 2007; Rajopadhye *et al.*, 2001; Weatherford & Kimes, 2003; Yüksel, 2007), and other autoregressive models (Burger *et al.*, 2001; Lim & Chan, 2011; Lim, Chang & McAleer, 2009; Yüksel, 2007). Historical methods are based on time series analysis:

### ✓ *Simple moving average*

The simple moving average forecast  $f_t$  for moment (period)  $t$  is an unweighted average of the actual values  $x_i$  of the variable for the preceding  $n$  moments (periods).

$$(9.1) f_t = \frac{\sum_{i=t-n}^{t-1} x_i}{n}$$

It can be calculated with daily, weekly, monthly, quarterly or annual data, and with different number  $n$  of past values of the variable. The larger the  $n$ , the lower the variation in the values of the moving average. In the simple moving average every past value  $x_i$  used in the calculation is considered to have equal importance on the value of the forecasted value  $f_t$  and, therefore, weight, regardless of its temporal distance from the moment (period) of the forecast.

### ✓ *Exponential smoothing*

In the exponential smoothing the past values of the variable  $x_i$  have different weights – they decrease with the temporal distance of the past values from the forecast value  $f_t$ . The forecast  $f_t$  depends on the actual value  $x_{t-1}$  and the forecast  $f_{t-1}$  of the variable in the preceding period:

$$(9.2) f_t = f_{t-1} + \alpha(x_{t-1} - f_{t-1}) = \alpha x_{t-1} + (1 - \alpha)f_{t-1},$$

where  $\alpha$  ( $0 < \alpha < 1$ ) is the smoothing factor and illustrates the portion of the previous period's forecast error  $x_{t-1} - f_{t-1}$  included in the forecast for the new period  $f_t$ . The

lower  $\alpha$ , the more weight it gives to all values prior to the last one, summarised in the  $f_{t-1}$  component of equation (9.2) (Frechtling, 2001: 88).

✓ *Other autoregressive models*

Besides the simple moving average and exponential smoothing, forecasting theory and practice uses other more sophisticated econometric techniques such as autoregressive moving average (ARMA), autoregressive integrated moving average (ARIMA), seasonal ARIMA (SARIMA), autoregressive conditional heteroskedastic model (ARCH), generalised ARCH model (GARCH), etc., discussed in details in Montgomery, Jennings & Kulachi (2008), which are also based on time series analysis.

The main advantages of historical methods are the relatively easy application and minimal data requirements – they need only historical data on the analysed variable. On the other hand, they rely on the fact that knowing how a certain variable has changed over time (e.g. what was the occupancy of the hotel during the last twelve months) can provide information on how this variable will change in the future, i.e. as if the variable has memory, similar to technical analysis in financial markets forecasting. This is the main disadvantage of time series forecasting – they disregard other variables – demand, competitors' actions or special events at the destinations that stimulate demand. Albeit their shortcomings, time series methods remain widely used.

**Advanced booking models** forecast the number of booked rooms on a particular arrival day on the basis of the number of booked rooms on a previous day (called 'reading day') and the 'pickup' of rooms (increase in the number of booked rooms) between the reading day and the arrival day (Phumchusri & Mongkolkul, 2012; Weatherford & Kimes, 2003; Zakhary, El Gayar & Atiya, 2008). Weatherford & Kimes (2003: 403) divide advanced booking models into additive and multiplicative models.

✓ *Additive models*

Additive models assume that the number of reservations on hand on a particular day before arrival is independent of the total number of rooms sold. In these models, the number of booked rooms on the reading day is added to the average historical pickup between the reading and the arrival (check-in) day. If  $x_{i,j}$  is the number of booked rooms for  $i$ -th check-in date  $j$  days before arrival, then  $d_{i,j} = x_{i,j} - x_{i,j-1}$  represents the

additionally booked rooms for  $i$ -th check-in date  $j$  days before arrival. The forecast  $f_{i,t}$  for the  $i$ -th check-in date  $t$  days before arrival would be (Phumchusri & Mongkolkul, 2012):

$$(9.3) f_{i,t} = \sum_{j=1}^t \bar{d}_j + x_{ij},$$

where  $\bar{d}_j$  is the average pickup of rooms between  $j$  and  $j-1$  days prior to arrival.

✓ *Multiplicative models*

Multiplicative model forecasts are based on the number of bookings on the reading day multiplied by the average historical pickup ratio. If  $m_{i,j}$  is the ratio of the increased number of booked rooms for  $i$ -th arrival date  $j$  days before arrival:

$$(9.4) m_{i,j} = \frac{x_{i,j}}{x_{i,j-1}},$$

then the forecast  $f_{i,t}$  for the  $i$ -th check-in date  $t$  days before arrival would be (Phumchusri & Mongkolkul, 2012):

$$(9.5) f_{i,t} = \left(\prod_{j=1}^t m_j\right) \cdot x_{i,j},$$

where  $\bar{m}_j$  is the average pickup ratio between  $j$  and  $j-1$  days prior to arrival.

It is evident that both additive and multiplicative models include a historical component and in this regard share the same disadvantages as the time series models discussed above.

As **combined methods** Weatherford & Kimes (2003) identify regression models (Burger *et al.*, 2001; Chen & Kachani, 2007; Weatherford & Kimes, 2003) and weighted average between historical and advanced booking forecasts (Chen & Kachani, 2007). *Regression models* present the dependent variable (number of booked rooms in the hotel, occupancy, ADR, RevPAR, GOPPAR, etc.) as a function of different independent variables  $x_i$ :

$$(9.6) f_t = F(x_1, x_2, \dots, x_i, \dots, x_n)$$

Their greatest advantage is that they allow the inclusion of numerous variables in the forecasting models (e.g. day of the week, special events, tourism demand and number of flights to the destination, marketing expenses of the hotel, timing of promotions, price levels, inflation, etc.) and, therefore, might provide superior forecasts compared to the preceding ones. Regression models may be successfully applied for tactical and especially strategic forecasting because they require mostly aggregated data potentially available on a monthly, quarterly and annual, but not on daily or weekly basis.

The *weighted average forecast*  $f_t$  between historical ( $f_t^{hist}$ ) and advanced booking forecasts ( $f_t^{ab}$ ) is:

$$(9.7) f_t = w^{hist} \cdot f_t^{hist} + (1 - w^{hist}) \cdot f_t^{ab},$$

where  $w^{hist}$  is the weight put on the historical forecast ( $0 < w^{hist} < 1$ ).

In addition to the above combined method we can add the *artificial neural networks* (Zhang, 2004) which warrant growing attention in tourism, hospitality and revenue management forecasting (e.g. Burger *et al.*, 2001; Law, 2000; Padhi & Aggarwal, 2011; Palmer, Montañó, & Sesé, 2006; Zakhary, El Gayar & Ahmed, 2010). In essence the artificial neural network is a computer programme with a non-linear mathematical algorithm that emulates the behaviour of the human brain. Past data on different variables is used to 'train' the model and develop the relationships among them. The trained model is then fed with the new values of the same variables used for forecasting. The artificial neural networks are superior to the other forecasting methods due to their learning capabilities. They may be used for any level of forecasting but could be especially useful for operational forecasting due to the large datasets with operational data generated in hotels.

**Qualitative methods** like Delphi (Yüksel, 2007) are based on experts' opinions rather than quantitative data. In the field of revenue management, they have only marginal applicability because they rely on the subjective perceptions of experts rather than objective statistical data.

The revenue manager should use several forecasting methods and not rely on only one. This raises the question of the selection of the most suitable forecasting model. In order to select a forecasting model, the forecasting accuracy of each should be evaluated. In practice, the most common statistics used for forecasting model evaluation include:

✓ *Mean absolute error* – shows the average difference between the actual ( $x_i$ ) and forecasted ( $f_i$ ) values of the variable:

$$MAE = \frac{\sum_{i=1}^n |x_i - f_i|}{n}$$

✓ *Mean absolute percentage error* – illustrates the average forecasting error as a percentage of the actual values of the variable.

$$MAPE = \frac{\sum_{i=1}^n \frac{|x_i - f_i|}{x_i}}{n} \cdot 100$$

✓ *Root mean square error* is the standard deviation of the forecasting errors:

$$RMSE = \sqrt{\frac{\sum_{i=1}^n (x_i - f_i)^2}{n}}$$

The model with the lowest *MAE*, *MAPE* and *RMSE* is the best choice among the competing models used by the revenue manager but this is not necessarily the mathematically more complex model. As Song & Li (2008: 217) in their review of tourism demand forecasting studies conclude: while ‘more advanced forecasting techniques tend to result in improved forecast accuracy under certain circumstances, no clear-cut evidence shows that any one model can consistently outperform other models in the forecasting competition’.

In practice, the quantitative forecasting will be performed with the help of appropriate software (Excel, SPSS, STATA) or it could be embedded in the chosen revenue management software.

# Chapter 10

## VALUE CREATION

Value is much discussed in academic literature but also a very elusive and vaguely defined marketing concept. Neap & Celik (1999) state that the ‘value of a product reflects the owner(s)/buyer(s) desire to retain or obtain a product’. Therefore following their definition, the product has value for both the hotel and its guests. Woodruff (1997: 140) elaborates that the concept of customer value ‘takes the perspective of an organization’s customers, considering what they want and believe that they get from buying and using a seller’s product’. On the other hand, Kotler *et al.* (2009: 385) stipulate that customer-perceived value is ‘based on the difference between what the customer gets and what he or she gives for different possible choices’, i.e. the cost associated with obtaining the product should also be considered when discussing the customer value. In this book we adopt the **expected value framework** developed by Ng (2009a). The product value is divided into four types on the basis of two grouping criteria – *gross* or *net*, *expected* or *perceived* value. Gross value is associated with the benefits received by the customer from the consumption of the product without taking into account the costs for obtaining the product. On the other hand, the net value considers these costs:

$$Net\ value = Gross\ value - Costs$$

Expected value is the value the customer thinks he will receive from the product during/after its consumption, while perceived value is the actual value obtained by customer. Table 10.1 summarises the four types of value:

**Table 10.1.** *Types of value*

	<i>Gross value</i>	<i>Net value</i>
<i>Expected value</i>	Expected gross value (EGV)	Expected net value (ENV)
<i>Perceived value</i>	Perceived gross value (PGV)	Perceived net value (PNV)



The **benefits** provided by the hotel can be numerous – rest and relaxation, tranquillity, convenience, enjoyment, ego enhancement, saving money, meeting other people, spending time with the family, adventure, fulfilment of a dream/fantasy, etc. The more the benefits, the higher the gross value of the product. Benefits are created by the hotel product attributes and are one of the bases for market positioning of the hotel (Ivanov & Zhechev, 2011). The attributes may be divided into tangible and intangible:

- ✓ *Tangible hotel product attributes* – location, hotel facilities, room amenities, room view, design of the hotel, colours, odour, space utilisation, etc.
- ✓ *Intangible hotel product attributes* – servicemindedness of the personnel (helpfulness, responsiveness, friendliness, courtesy), speed of the service, service personalisation, safety, cleanliness, atmosphere, etc.

Tangible product attributes are easy to copy by competitors. That’s why they are seldom sources of a sustainable competitive advantage of the hotel. Emphasis should be put on the intangible attributes as they are more difficult to imitate. The marketing manager communicates the product attributes to the target markets to form in them expectations about the benefits guests will gain from booking in the particular hotel, but we should not forget that ‘buyers buy benefits, not attributes’ (Ng, 2009a: 27) – they do not care about the room itself but the relaxation it provides.

For each hotel service the marketing manager may develop a ‘product attributes-product benefits’ matrix showing the relationships among them (see Table 10.2 for an exemplary matrix). Such a matrix helps the managers identify the key product attributes and excel in their provision.

**Table 10.2.** *Product attributes-product benefits matrix*

		<i>Product benefits (perceived by the customer)</i>				
		B <sub>1</sub>	B <sub>2</sub>	B <sub>3</sub>	B <sub>4</sub>	B <sub>5</sub>
<i>Product attributes (provided by the hotel)</i>	A <sub>1</sub>	✓			✓	
	A <sub>2</sub>		✓	✓	✓	
	A <sub>3</sub>			✓		
	A <sub>4</sub>				✓	
	A <sub>5</sub>					✓
	A <sub>6</sub>		✓			

One product attribute may contribute to one or several benefits (e.g. A<sub>1</sub> contributes to B<sub>1</sub> and B<sub>4</sub>, while A<sub>6</sub> to B<sub>2</sub> only). Similarly, one benefit may be generated by one or several attributes (e.g. B<sub>3</sub> by A<sub>2</sub> and A<sub>3</sub>, while B<sub>5</sub> only by A<sub>5</sub>). Key attribute is the one that contributes to the greatest number of product benefits valued by hotel guests – in the case of Table 10.2 this is A<sub>2</sub>. The most composite benefit is the one created by the greatest number of product attributes – in our example this is B<sub>4</sub>. Companies manage the product attributes in order to deliver the expected product benefits sought by the hotel guests and their perceptions of these benefits.

The same product benefits, however, may be valued differently by the various market segments, i.e. the same benefit may be derived by different product attributes depending on the target market segment. Table 10.3 presents a sample incomprehensive list of product attributes associated with the same benefit ('convenience') for two distinct market segments – business travellers and families with small children. Each of the two market segments values the different product attributes differently and the hotelier should be familiar with this when preparing the 'right product' for the 'right customer'.

**Table 10.3.** *Product attributes by market segment of 'convenience' as a product benefit*

<i>Product benefit: Convenience</i>	
<i>Segment: Business travellers</i>	<i>Segment: Families with small children</i>
<i>Product attributes:</i>	<i>Product attributes:</i>
✓ Online booking	✓ Someone to organise the whole trip – hotel contracts with tour operators
✓ Various electrical sockets in the hotel room	✓ Babysitting
✓ Wi-Fi	✓ Kids club
✓ Working desk	✓ Pools
✓ Location in/near the central business district	✓ Location next to tourist resources
✓ Express check-in/check-out, etc.	✓ Large family rooms, etc.

One of the main concerns for hoteliers is the commodification of hotel product (Baker, 2014). As already discussed in Chapter 3, through the online travel agencies (*Booking.com, Venere.com, Expedia.com, Orbitz.com, etc.*) customers can easily check the prices for hundreds of hotels in a destination, and through meta search engines (*Kayak.com, Hotelscombined.com, Trivago.com, etc.*) they could compare the prices for the same hotel via different OTAs and select the lowest price. Therefore certain market segments become more interested in price rather than the value they would receive from the hotel product, thus forcing hotels to enter into price competition. The way to

counteract the process of commodification of the hotel product is through its differentiation from competing products and redefining the benefits it offers. A useful instrument a hotel may use for implementing differentiation is the adoption of the experience economy philosophy.

Developed at the end of the 1990s by Pine & Gilmore (1998, 1999) the concept of *experience economy* gained popularity in the tourism and hospitality industry as well (Andersson, 2007; Gilmore & Pine, 2002; Oh, Fiore & Jeoung, 2007). Experiences are perceived as products that are different from goods and services. Pine & Gilmore (2011: 17) emphasise that 'experience offerings occur whenever a company intentionally used services as the stage and goods as props to engage an individual. Whereas commodities are fungible, goods tangible, and services intangible, experiences are *memorable*' (Italics in original). In order to be competitive, the firm should offer positive, sensational, memorable, and long-lasting experiences, which stimulate the customers to talk about them and to repeat their purchases. Experiences are the basis of the entertainment business – theme parks, rock concerts, movies, virtual reality of the video/online games, kids' birthday parties (at McDonald's or specialised kids clubs), etc. Experiences do not result in the ownership of something – the customer 'buys' memories, which justify charging a higher price for 'participating' in the experience. Company employees create personalised services and influence the emotions of the guests. A key moment is the participation of the customer in the experience delivery process, i.e. he is transformed into a 'prosumer' (producer + consumer) – the customer is simultaneously a consumer of the experience and an actively engaged participant in its staging. The design of the service experience (Patricio *et al.*, 2011) requires that all elements of the company product and service delivery process be coordinated – the stages of the service delivery process, the level of customer participation in the service process, his interactions with other customers and employees, the atmosphere and physical environment of the hotel, the employee uniforms, the restaurant menu, the usage of all five senses to communicate the experience message (the value) to the customer.

In the hotel industry, the adoption of the experience economy philosophy leads to the development of experiential hotel product concepts. Table 10.4 provides multiple examples of different degrees of application of the experience economy philosophy adopted by hotels in various destinations worldwide. Experience effect is achieved by

unique design and shape of the hotel building, its location, specific target market segment, services, specific service delivery process, animation programme, etc. The table reveals that memorable experiences may be offered not only by deluxe properties, but also by hotels with modest facilities; not only by large hotels, but by accommodation establishments with a couple of rooms only too.

**Table 10.4.** *Application of the experience economy philosophy in hotels' product concepts*

<b>Hotel / website</b>	<b>Location</b>	<b>Experiential element in the product concept</b>
Arena di Serdica <a href="http://www.arenadiserdica.com">http://www.arenadiserdica.com</a>	Sofia, Bulgaria	Ancient amphitheatre in the lobby
Sokolovo monastery <a href="http://www.bulgarianmonastery.com">http://www.bulgarianmonastery.com</a>	Gabrovo, Bulgaria	Accommodation in the rooms of a working monastery
Helena Resort <a href="http://www.helenaresort.com">http://www.helenaresort.com</a>	Sunny Beach, Bulgaria	Elements of Bulgarian renaissance architecture, more than 1500 pieces of art
Ariau Amazon Towers Hotel <a href="http://www.ariauamazontowers.com">http://www.ariauamazontowers.com</a>	50 km from Manaus, Brazil	Several buildings located above the Rain Forest
Ashford Castle <a href="http://www.ashford.ie">http://www.ashford.ie</a>	Mayo, Ireland	Castle
Beckham Creek Cave Haven <a href="http://www.beckhamcavelodge.com/">http://www.beckhamcavelodge.com/</a>	Parthenon, Arkansas, USA	Located in a cave
Brunelleschi <a href="http://www.hotelbrunelleschi.it">http://www.hotelbrunelleschi.it</a>	Florence, Italy	Lobby integrating a Byzantine tower and museum
Cove Pocono Resort <a href="http://www.covepoconoresorts.com/">http://www.covepoconoresorts.com/</a>	Pennsylvania, USA	Theme: love and romance
Cedar Creek Treehouse <a href="http://www.cedarcreektreehouse.com">http://www.cedarcreektreehouse.com</a>	Ashford, Washington, USA	House located on a tree
Club Med <a href="http://www.clubmed.com">http://www.clubmed.com</a>	Various countries	All-inclusive holiday villages with rich animation programme
Controversy Tram Hotel <a href="http://www.controversy.nl">http://www.controversy.nl</a>	Hoogwoud, Netherlands	Accommodation in trams transformed into guest rooms
Four Seasons Resort Bali at Sayan <a href="http://www.fourseasons.com/sayan">http://www.fourseasons.com/sayan</a>	Bali, Indonesia	Theme: solitude, tranquillity and silence in the Rain Forest
Golden Bear Hotel <a href="http://www.goldenbear.nl">http://www.goldenbear.nl</a>	Amsterdam, Netherlands	Gay hotel
Harbour Crane Hotel <a href="http://www.vuurtoren-harlingen.nl">http://www.vuurtoren-harlingen.nl</a>	Harlingen, Netherlands	Harbour crane transformed into a hotel

Hotel / website	Location	Experiential element in the product concept
Harlingen Lighthouse <a href="http://www.vuurtoeren-harlingen.nl">http://www.vuurtoeren-harlingen.nl</a>	Harlingen, Netherlands	Lighthouse transformed into a hotel
Huvafen Fushi <a href="http://www.huvafenfushi.com">http://www.huvafenfushi.com</a>	Maldives	Wellness with an underwater spa centre
Ice Hotel <a href="http://www.icehotel.com">http://www.icehotel.com</a>	Jukkasjärvi, Sweden	Ice hotel
Jules Undersea Lodge <a href="http://www.jul.com">http://www.jul.com</a>	Key Largo, Florida, USA	Underwater hotel
Jumeirah International Hotels <a href="http://www.jumeirah.com">http://www.jumeirah.com</a>	United Arab Emirates	Luxury, iconic building design
Kremlin Palace <a href="http://www.wowhotels.com/kremlin">http://www.wowhotels.com/kremlin</a>	Antalya, Turkey	Copy of the Kremlin, Moscow
Library Hotel <a href="http://www.libraryhotel.com">http://www.libraryhotel.com</a>	New York, USA	The hotel houses a library with more than 6000 books
Luxor Hotel And Casino <a href="http://www.luxor.com">http://www.luxor.com</a>	Las Vegas, Nevada, USA	Pyramid shape
Plane Motel <a href="http://www.woodlynpark.co.nz">http://www.woodlynpark.co.nz</a>	Woodlyn Park, New Zealand	Airplane transformed into a 2-room hotel
Quinta Real Zacatecas <a href="http://www.quintareal.com.mx">http://www.quintareal.com.mx</a>	Mexico	Former corrida arena transformed into a hotel
Legoland Windsor Resort <a href="http://www.legoland.co.uk/">http://www.legoland.co.uk/</a>	United Kingdom	Theme: Lego toys
Walt Disney Hotels <a href="http://disneyworld.disney.go.com">http://disneyworld.disney.go.com</a>	USA, France, Japan	Theme: Walt Disney Movies
Erlebnishotel Jailhotel <a href="http://www.jailhotellowengraben.hotelswhiz.info">http://www.jailhotellowengraben.hotelswhiz.info</a>	Lucerne, Switzerland	Former jail transformed into a hotel
The Palace of the Lost City <a href="https://www.suninternational.com">https://www.suninternational.com</a>	Sun City, South Africa	Hotel resembles the palace of an ancient king
Vritomartis Hotel <a href="http://www.vritomartis.gr">http://www.vritomartis.gr</a>	Crete, Greece	Hotel for nudists

The **costs** associated with obtaining the hotel product could be monetary or nonmonetary. *Monetary costs* include the price and all financial expenses the customer must pay for to purchase and consume the hotel product (e.g. credit card charges). They are relatively easy to control by the revenue manager by changing the price of the hotel product. *Nonmonetary costs* do not have a financial equivalent but they might

determine whether or not the customer will make the effort to purchase and consume the product. In particular, nonmonetary costs include (Ng, 2009a):

✓ *Time* necessary for the customer to search for information, prices and room availability at suitable hotels in the destination he is going to visit, to evaluate the alternatives, to make a booking, to wait to receive confirmation, etc. The longer the time needed to be spent on the above activities, the higher the nonmonetary costs for the consumer.

✓ *Social costs* relate to the loss/gain of personal image by the customer and the answer to the question 'What would others think if they see me in this hotel'? If staying in a particular hotel would be perceived by customer's peers/colleagues/relatives/reference group members as inappropriate (e.g. a CEO of a large corporation staying in a 2-star property during a business trip), then the customer's perceptions about the social costs will be high.

✓ *Psychological costs* stem from the unknown and uncertainty – e.g. a highly sophisticated hotel product that causes psychological inconvenience because the customer does not know how to behave in the hotel or how to use its technology.

✓ *Opportunity costs* are associated with the costs to acquire a competing product. Booking in a particular hotel means that the customer rejected an alternative. If the other option was very attractive the customer faces high opportunity costs and vice versa – the less attractive the alternative, the lower the opportunity costs.

Relationships between expected and perceived benefits and costs influence the choice of a hotel by customers and their satisfaction from the stay. Figure 10.1 elaborates the **value framework of hotel selection**. The customer assesses the benefits he would receive from hotels A, B, C, etc. Following the definitions at the beginning of the chapter, these expected benefits form the expected gross values of the hotels:  $EGV_A$ ,  $EGV_B$ ,  $EGV_C$ . Each hotel product is associated with some expected costs (monetary and nonmonetary):  $EC_A$ ,  $EC_B$ ,  $EC_C$ . The difference between  $EGV$  and  $EC$  gives the expected net values of each competing hotel:  $ENV_A$ ,  $ENV_B$ ,  $ENV_C$ . The customer then compares the  $ENV$ s of the hotels in his consideration set and selects the one in which to book a room, considering his budget constraints. In order to be selected by the customer the  $ENV$  of the hotel must be higher than the  $ENV$  provided by competing hotels at the destination. Table 10.5 below summarises the situations when the  $ENV$  of a particular hotel is higher or lower than the  $ENV$  of its competitors.

Calculation of competing hotels' ENVs

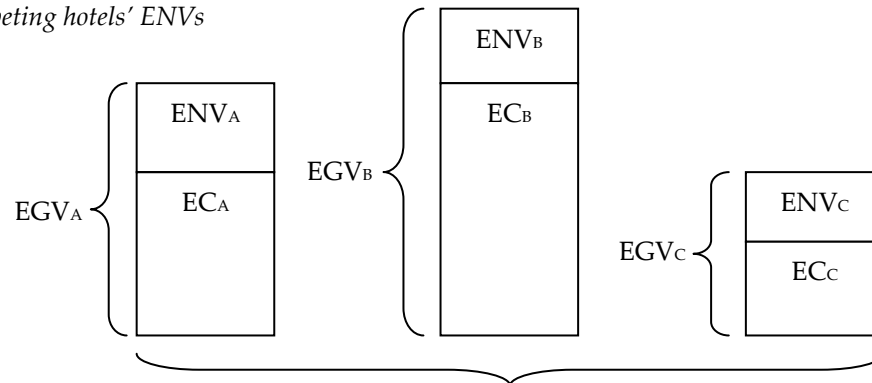

Comparison of ENVs

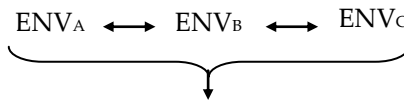

Choice of a hotel and purchase intentions

Hotel A

**Figure 10.1.** The value framework of hotel selection

**Table 10.5.** ENV competitive comparison

Situation	ENV <sub>A</sub> ↑		Situation	ENV <sub>A</sub> ↓	
	EGV <sub>A</sub>	EC <sub>A</sub>		EGV <sub>A</sub>	EC <sub>A</sub>
[1]	↑↑	↑	[5]	↑	↑↑
[2]	↑	=	[6]	=	↑
[3]	=	↓	[7]	↓	=
[4]	↓	↓↓	[8]	↓↓	↓

↑↑ - much higher than competitors

↑ - higher than competitors

= - same as competitors

↓ - lower than competitors

↓↓ - much lower than competitors

It should be noted that only hotels within the same price category may be considered as competing hotels and thus compared. A 5-star hotel will offer a very high EGV compared to a 2-star property, which although partially offset by its very high EC, will lead to a higher ENV than the ENV of a 2-star property. This, however, does not mean that a hotel with a higher ENV (in this case the 5-star hotel) will be booked by the customer due to budget limitations.

The value framework of hotel selection is important for revenue managers because it shows that the ENV of the hotel product could be changed by managing the expected benefits (EGV), the expected costs or both simultaneously. In order to avoid the

commodification of the product and the price competition, the revenue manager could increase the chances of his hotel to be selected by the customer by influencing customers' perceptions on the product benefits. When expected benefits increase provided constant expected costs or they increase faster than the costs, then the ENV of the product increases. This puts the emphasis on *communicating the value* of the product to the target customers, rather than decreasing the price. On the other hand, the ENV could be increased if the costs for the customer are lowered. If the price is kept at same level then the revenue manager should influence the nonmonetary costs for booking at his hotel:

*Tactics to decrease the time costs:*

- ✓ High market visibility and wide online presence of the hotel in different distribution channels (GDSs, OTAs, tour operators, chain's online reservation system, property's website, etc.).
- ✓ The hotel works on commitment, allotment or free sale basis with its distributors (see Chapter 13) so that customers could check availability in real time and receive instant confirmation.
- ✓ All booking inquiries are dealt in a timely manner with a sense of urgency.

*Tactics to decrease the social costs:*

- ✓ Clear and well communicated segmentation and market positioning strategies (customers would know whether the hotel is for them).
- ✓ Affiliation to a hotel chain (customers would know what to expect from the hotel).

*Tactics to decrease the psychological costs:*

- ✓ Provision of ample information on spot and on the website about hotel's services, facilities, technologies, product characteristics, etc.
- ✓ Advertising in order to utilise the 'I've-seen-it-on-TV' effect as people trust familiar products, although they might have never used them.
- ✓ Affiliation to a hotel chain.
- ✓ Provision of a 100% satisfaction guarantee

*Tactics to decrease the opportunity costs:*



- ✓ Clear communication of superior product benefits that distinguish the hotel from its competitors.
- ✓ Clear booking conditions to facilitate the easy comparison with competitors' booking conditions.

Figure 10.2 illustrates the **value framework of repeat purchases**. The customer evaluates the perceived gross value  $PGV_A$ , the perceived costs  $PC_A$  and the resultant perceived net value  $PNV_A$  received from consuming the hotel product. The  $PNV_A$  is then compared with the  $ENV_A$ :

- ✓ If  $PNV_A < ENV_A$  the customer is dissatisfied as he received less than expected;
- ✓ If  $PNV_A = ENV_A$  the customer is satisfied as he received the same as expected;
- ✓ If  $PNV_A > ENV_A$  the customer is delighted as he received more than expected.

*Calculation of PNV of the booked hotel*

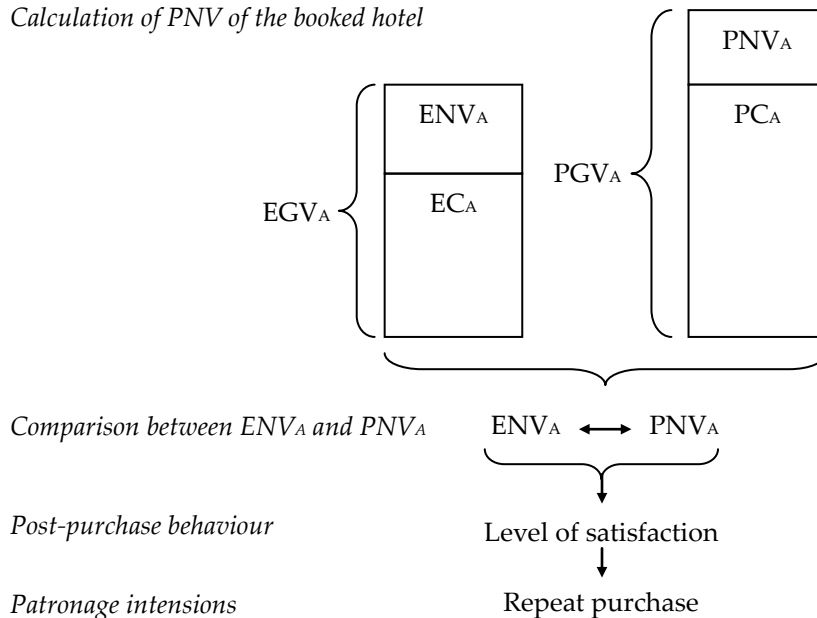

**Figure 10.2.** *The value framework of repeat purchases*

The perceived value received by the hotel guest would depend on several groups of factors, which influence the service delivery process in the hotel, the consumption of the hotel product by the customer and his mood, attitudes, and behaviour:

- ✓ *The hotel* – hotel facilities, room amenities, service process, employee appearance, employee attitude towards the customer, their attitude towards the other customers, provided information, etc.

- ✓ *The customer him/herself* – his/her mood, behaviour, attitudes, appearance, health, etc. as he is a prosumer in the process.
- ✓ *Accompanying persons, other guests in the hotel, other tourists in the destination* – their mood, behaviour, attitudes, appearance, health, etc.
- ✓ *External circumstances* – weather, events in the destination, behaviour and attitudes of local population towards the tourists.

Obviously, only part of the factors are completely (or nearly entirely) controllable by the hotel, while most are either partially controllable (the customer, his accompanying persons, other guests and tourist) or completely uncontrollable (external circumstances). Therefore, the PNV to be received by the hotel guest is uncertain which, increases the perceived risk for him. In order to mitigate this perceived risk some hotel chains, like Hampton, provide a 100% service satisfaction guarantee to their customers (Hampton, 2014) which will be discussed in details in Chapter 12.

From a revenue management perspective satisfied and delighted customers are more likely to repeat their purchase and stay again in the hotel. However, research shows that in case of a service failure by the company, a good service recovery (swift solution of customer problems with proper compensation) might transform the dissatisfied, angry and annoyed customers into satisfied and loyal ones (Skaalsvik, 2012). However, it should be emphasised that in order to come to the same hotel, tourists have to select the destination as a whole again. Therefore, *the repeat purchase of the tourist would depend not only on the net value provided by the hotel, but on the total net value of the destination product as a whole*, which mostly goes beyond the control of the revenue manager of the hotel (chain). This raises the necessity hoteliers, tour operators and travel agents, transportation companies, tourist attractions, destination management companies and all other destination stakeholders to work together in order to provide a memorable destination experience for the tourists and stimulate their loyalty, which would be beneficial for all economic agents in the destination, including the hotels.

## Chapter 11

### PRICING HOTEL REVENUE MANAGEMENT TOOLS

Price is a very important element of a hotel's marketing mix – it is the only one directly connected with hotel's revenues (see Figure 1.1). Many scholars have identified the importance of pricing and price strategy as a basis for creating sustainable competitive advantage (Cross, Higbie & Cross, 2009; Desiraju & Shugan, 1999; Nagle & Hogan, 2006; Ng, 2009a, b; Shy, 2008). In the hotel industry the most widely used pricing revenue management tools include price discrimination, dynamic pricing, lowest price guarantee, price presentation and, price parity and they have been extensively researched in academic literature (Choi & Kimes, 2002; Hanks, Cross & Noland, 2002; Koenig & Meissner, 2010; Lieberman, 2011; Mauri, 2012; Noone & Mattila, 2009; Schwartz, 2006, 2008; Steed & Gu, 2005; Tranter, Stuart-Hill & Parker, 2008; Tse & Poon, 2012) for both individual and group booking requests (Choi, 2006; Cross, Higbie & Cross, 2009; Schwartz & Cohen, 2003). In practice, price is one of the (strongest) instruments for market positioning of a hotel (Ivanov & Zhechev, 2011) as it is included in all market positioning models – the Bowman strategy clock (Bowman, 1991), the value positioning (Kotler *et al.*, 2002), and the positioning maps (Lovelock & Wright, 1999). Due to the information function of price (Chen, Ruseski & Schwartz, 2009), customers form expectations about the service quality according to service price (among other factors) and the higher price is an implicit promise for higher quality (Wilson, Zeithaml, Bitner & Gremler, 2012). Therefore, pricing also influences the expected value of the hotel product (see Chapter 10).

#### 11.1. Constellation of prices in the hotel industry

The hotel industry is famous for using a myriad of prices. Table 11.1 below summarises some of the criteria for differentiating the price. Room prices may vary according to the type of room, room standard, food board, room view, period of accommodation, time of booking, booking terms (cancellation, amendment and

payment terms), length-of-stay, distribution channel, guests' characteristics, their loyalty, group size, etc. In fact, revenue managers might develop more criteria for price differentiation as long as these criteria justify the application of different prices. It should be noted that price differentiation criteria cited in Table 11.1 have different practical applicability and importance for the hotel. While it is easily justifiable to use criteria based on product characteristics (board, room type, room standard, room view) leading to different service value expectations and perceptions among customers, it is not with some other criteria. Customer characteristics, for example, are highly controversial and disputable price differentiating factors as they raise the question of why some customers should pay higher prices than other guests in the hotel only because of their characteristics. When customers' age is concerned there is a general tacit consensus among hoteliers to provide discounts for children in order to attract families, and sometimes for senior customers. Nationality, however, causes much more concerns because it discriminates against some customers in favour of others on the basis of the issuer of their passport. That's why in some countries, like Bulgaria, it is illegal for hotels to charge different prices for domestic versus foreign guests.

**Table 11.1.** *Types of prices in the hotel industry*

<b>Price differentiation criteria</b>	<b>Type of prices</b>
<i>Type of services</i>	Prices in the various revenue centres of the hotel – rooms, restaurant, bar, minibar, sport facilities, parking, etc.
<i>Board</i>	Room only, Bed and breakfast, Half board, Full board, All inclusive
<i>Room type</i>	Single, double/twin, triple, family room, studio, suite, apartment
<i>Room standard</i>	Standard, superior, deluxe, executive rooms
<i>Room view</i>	Sea/Garden/Park/Mountain view
<i>Time-based criteria</i>	<ul style="list-style-type: none"> <li>• Weekday/weekend prices</li> <li>• Seasonal prices – main, shoulder, off-season prices</li> <li>• Booking lead period – discounts for early bookings</li> <li>• Length-of-stay – lower prices for longer stays</li> </ul>
<i>Payment terms</i>	Lower rates for bookings with immediate payment
<i>Cancellation terms</i>	Lower rates for bookings without free cancellation
<i>Distribution channel</i>	Rack rates, prices for the various categories of distributors
<i>Demographic characteristics of guests</i>	Age (prices for children, adults and senior guests) Nationality
<i>Specific characteristics of guests</i>	Special rates for government/municipal/army personnel, business travellers, honeymooners, participants in incentive trips, travel agency employees, etc.
<i>Group size</i>	Rate for individual guests and groups
<i>Guest loyalty</i>	Special rates (lower or free overnights) for guests participating in loyalty programmes

## 11.2. Factors, influencing pricing decisions in the hotel

Revenue management decisions in relation to pricing experience the impact of various factors from the macro, micro- and the internal environment of the hotel. Table 11.2 below elaborates on some of these factors that the revenue manager might consider and their potential impact on the price and/or the pricing process. The factors may have different impact magnitude and importance for every accommodation establishment depending on the situation.

**Table 11.2.** *Factors, influencing pricing decisions in the hotel*

<b>Factor</b>	<b>Impact on pricing</b>
<i>Category</i>	Higher prices for higher category properties
<i>Quality / value</i>	Higher prices for hotels delivering higher value to their customers
<i>Image</i>	Positive image leads to higher prices than competing hotels
<i>Product lifecycle stage</i>	Lower prices during introduction and decline stages, higher during maturity
<i>Additional services included in the price</i>	More included services lead to price escalation
<i>Location</i>	Hotels closer to tourist resources boast higher prices
<i>Competition</i>	Serves as a benchmark
<i>Sales volume</i>	Lower prices (discounts) for guests (distributors) booking more rooms
<i>Demand</i>	Higher prices during periods of high demand (e.g. special events)
<i>Demand elasticity</i>	Lower prices for price sensitive customers, higher prices for less price sensitive customers
<i>Affiliation to a hotel chain</i>	Payment of franchise/management fees increases costs and, thus, prices
<i>Bargaining power of distributors</i>	High distributor bargaining power leads to lower prices
<i>Company's marketing strategy and goals</i>	Focused differentiation strategy is related to high prices, while market penetration to low prices
<i>Organisational structure</i>	Determines who has the responsibility for pricing within the company
<i>Taxation</i>	Positive relationship with prices
<i>Government regulations</i>	Setting price ceilings (maximum prices) or price floors (minimum prices)
<i>Costs</i>	From an accounting perspective costs are a pricing factor. From a marketing perspective customers are interested in their costs (price, time, social costs, etc.) and the value they receive, not the costs of the company.

*Note:* developed by the author on the basis of Enz, Canina & Liu (2008); Hung, Shang & Wang (2010); Ivanov & Zhechev (2011); Kotler, Bowen & Makens (2006); Portolan (2013); Roper (2013)

### 11.3. Pricing revenue management tools

#### Price discrimination

Price discrimination is at the heart of pricing RM tools (Hanks, Cross & Noland, 2002; Ivanov, 2013; Kimes & Wirtz, 2003; Mauri, 2012; Ng, 2009b; Shy, 2008; Tranter, Stuart-Hill & Parker, 2008). In essence, price discrimination means that the hotel charges its customers different prices for the same rooms. The economic rationale for this is the difference in price elasticity of hotels' market segments (see Chapter 2) – e.g. business travellers are less price sensitive compared to leisure travellers and may afford to pay higher prices. Figure 11.1 graphically depicts the economic rationale behind price discrimination.

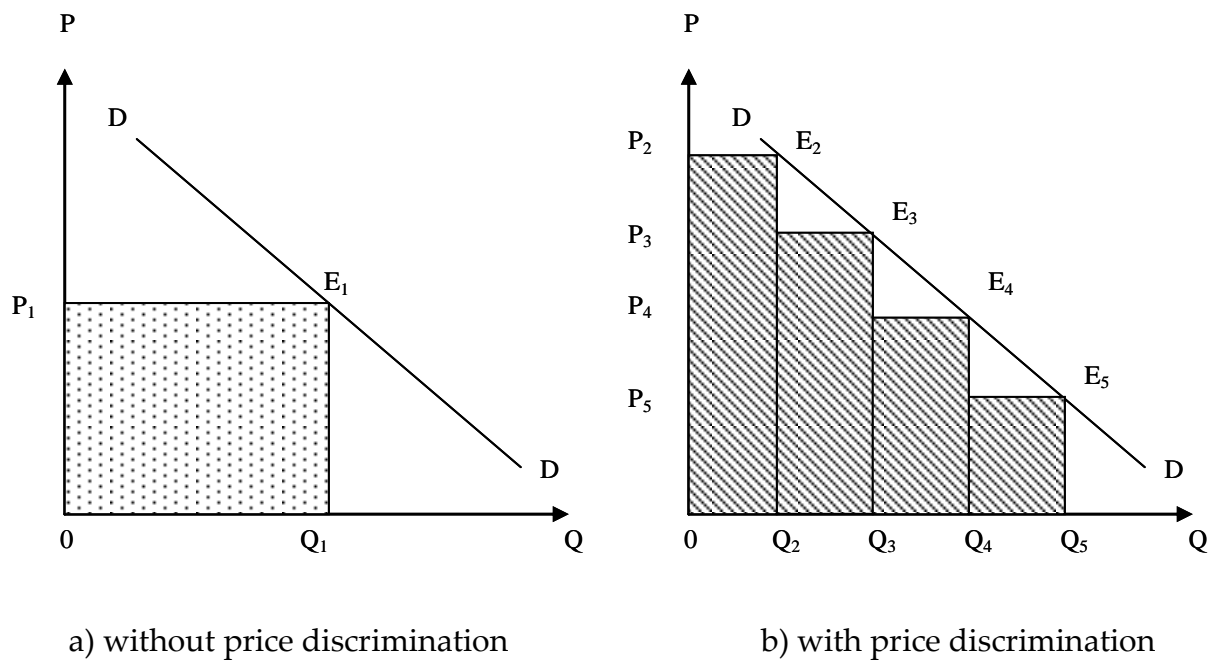

**Figure 11.1.** Hotel revenues without (a) and with (b) price discrimination

If the hotel charges its customers only one price (Figure 11.1.a), its total room revenues are represented by the dotted rectangle  $0Q_1E_1P_1$ . Price  $P_1$  is too high for some customers and they will not book at that hotel (the section of the  $DD$  demand curve to the right of  $E_1$ ), i.e. the hotel will lose revenues due to unsold rooms to these market segments. On the other hand, price  $P_1$  will be too high for other customers who may be willing to pay a higher price than they are actually charged (the section of the  $DD$  demand curve to the left of  $E_1$ ), i.e. the hotel loses revenues due to low

price for these market segments. If the hotel applies price discrimination (Figure 11.1.b) different market segments will be charged different prices –  $P_2, P_3, P_4, P_5$ , thus leading to higher total room revenues (the total area of the four striped rectangles) compared to the situation without price discrimination.

However, to avoid migration from high to low priced products, hotels introduce *price fences* (Zhang & Bell, 2010, 2012) defined as the conditions under which specific rates are offered on the market. Such hotel price fences may include day of the week, duration of stay, guest characteristics (e.g. belonging to a club, government employee), cancellation, amendment and payment terms, lead period, age and other criteria for price differentiation presented in Table 11.1 (Hanks, Cross & Noland, 2002; Ivanov, 2013; Kimes, 2009; Kimes & Chase, 1998). In practice, rate fences are integrated into the booking terms and conditions and determine the validity of the specific room rate.

The set of price levels and their associated booking terms are referred to as *price grid*. In order to avoid dissatisfaction and claims from customers, the price grid should be completely clear to the customer at the time of booking and be consistent. *Price consistency* (or *price integrity*) refers to the logic behind the set of prices and their associated booking terms. Price grid for a hotel is consistent if prices are:

- *Proportionate to the rights booking terms provide to the customers*: the higher the price a customer pays, the more rights to cancel and amend the booking he must have, and vice versa. For instance, prices without free cancellation should be lower than prices with free cancellation, while prices with compulsory full prepayment should be lower than prices with payment on the spot.

- *Stimulating customers who plan in advance*: providing discounts for early bookings rather than last-minute offers. Early bird rates stimulate customers to book their stay earlier rather than postpone their decision. They are an effective way to discriminate leisure from business travellers because leisure travellers have a longer planning horizon. Nevertheless, when the forecasted occupancy for a particular date is low, the revenue manager has greater incentive to provide very low rates for last minute bookings because the pure economic logic says that it would be better to get at least some revenues from the rooms that will otherwise remain vacant. However, offering deeply discounted last minute rates punishes the guests who have booked their rooms well in advance. Excessive use of last-minute offers by accommodation

establishments and the rise for specialised websites for last minute deals (like *Lastminute.com*) contribute to the commodification of the hotel product (see Chapter 10) and the increased emphasis on price when customers select accommodation. That's why last-minute offers should be less beneficial for the guests than early bird offers. They must be tied with restricting booking terms regarding offer validity, cancellations, amendments and/or requirements for advance payment to justify the low rate.

- *Stimulating customers who stay longer in the hotel*: providing discounts for longer stays either directly as a lower rate per night or as a free overnight (e.g. hotels' special offers 5=4/'Stay 5, pay 4 overnights'). Offering a free overnight is more acceptable from a revenue management perspective than the lower price because: a) the price remains unchanged and customers do not form unjustified expectations about future low rates at the hotel; b) customers stay longer in the hotel which provides greater opportunities to sell more additional services to them; and c) guests with shorter stays would not take advantage of the promotion.

- *Stimulating customers who pay for more services*: providing discounts to guests who use more services at the hotel. Some casino hotels provide heavily discounted or even free rooms to guests known to spend a lot in the casino.

- *Stimulating regular guests*: rates for guests participating in the loyalty programme of the hotel (chain) should be lower than or at least the same as rates for other guests with the same booking terms.

- *Providing price parity*: final prices for the customers are nearly the same regardless of the distribution channel used to book the room. When customers see excessive differences in the prices for the same hotel, room type, stay period and booking terms in different distribution channels, they feel uncertain about the price and the service value, and may postpone their booking or even switch to another property. In this regard, some hotels and hotel chains include in their contracts with tour operators a requirement for a minimum mark-up in order to decrease the difference between the selling price of the tour operators and hotels' special offers valid only for direct customers.

### *Dynamic pricing*

One of the integral concepts of pricing nowadays is dynamic pricing (Abrate, Fraquelli & Viglia, 2012; Aziz *et al.*, 2011; Bayoumi *et al.*, 2013; Palmer & Mc-Mahon-Beattie, 2008; Tranter, Stuart-Hill & Parker, 2008). It allows a hotel to maximise



RevPAR and yield by offering a price reflecting current level of demand and occupancy, and amend it according to changes in demand and occupancy rate. The revenue manager checks the RM metrics and opens or closes lower price levels depending on their values. Here the booking curves (Figures 8.3 and 8.4) are very helpful – if bookings accrue at a slower pace than for the same date during the previous year, the revenue manager will probably consider a lower price level in order to stimulate demand. As a result, customers frequently pay different prices even when they have one and the same booking details (period of stay, board basis, number and types of rooms) depending on the moment of reservation. In this regard, dynamic pricing is subject to criticism by customers. Nevertheless, from a financial point of view, dynamic pricing can provide higher profitability, but it should be applied carefully and accompanied by ample information about booking terms and conditions, similar to price discrimination.

#### *Lowest price guarantee*

Sometimes hotels provide to their customers a lowest price guarantee (Carvell & Quan, 2008; Demirciftci, Cobanoglu, Beldona & Cummings, 2010). According to it, if a customer finds a lower price for the same or similar hotel within a predetermined period of time after their booking (usually 24 hours), the hotel will match that lower price. Table 11.3 below illustrates the types of lowest price guarantee on the basis of two criteria – period of validity of the guarantee and the hotel whose price is used as a benchmark price for the guarantee.

**Table 11.3.** *Types of lowest price guarantee*

		<b>Benchmark hotel</b>	
		<i>Same</i>	<i>Similar</i>
<b>Validity</b>	<i>24 hours</i>	Type I	Type III
	<i>The whole period from booking date to check-in date</i>	Type II	Type IV

✓ *Type I guarantee* – if the customer finds a lower price for the same hotel within 24 hours of the booking, the hotel will match that price and probably provide further discount. Marriott, for example, promotes the *Look No Further® Best Rate Guarantee* with the following rules (Marriott.com, 2014):

– The customer books a room in a Marriott hotel using any Marriott reservation channel (Marriott.com, Marriott Hotel Telephone Reservations, or directly at a hotel).

– If within 24 hours of making the reservation, the customer finds a lower hotel rate for the same hotel, room type and reservation dates, and submits a qualified claim form, Marriott will match the rate and give an extra 25% discount on that price.

Carvell & Quan (2008) examine this type of lowest price guarantee by applying the financial option pricing model and determine that it has no practical value for the customers because the search period is too short and does not provide long enough time window for significant price volatility. For customers to benefit from lowest price guarantee, authors stipulate that the guarantee should cover the full period from the booking date until the arrival date, not just the period spanning 24 hours after the booking date, i.e. the Type II guarantee. Similarly, Demirciftci *et al.* (2010) negate the lowest price guarantee claim by several US hotel chains, advertised on their websites.

✓ *Type II guarantee* – the same as Type I guarantee but the period of validity of the guarantee covers the whole period between the booking and check-in dates. If it is not a last-minute booking, this time window provides enough time for significant price volatility and has financial value to the customers. If, for instance, the customer books three months before check-in and receives a Type II guarantee, then he would be eligible for the promotions offered by the hotel during these three months and valid for his period of stay. This means that the new promotions will have *retroactive validity* for bookings with the promotional period of stay but made before the promotion was even offered on the market. On one hand, this has a positive impact on customers' perceptions about *price integrity* – they booked in advance and are sure that they will pay the lowest price available during the period between the booking date and the check-in date. On the other hand, the Type II guarantee limits the opportunities for the revenue manager to offer promotions due to their retroactive validity on guests with a Type II guarantee. Nevertheless, as Carvell & Quan (2008) reveal, it is better than the Type I guarantee.

✓ *Type III guarantee* is based on Type I guarantee, but the revenue manager extends the benchmark price to a set of competing hotels. In this case, the customer may not only look at the prices of the hotel he initially booked but also of other hotels at the destination of the same category, location, room types. Type III guarantee assumes that customers are more interested in being accommodated at a given destination than at a particular hotel. To a certain degree, this guarantee

stimulates price competition among hotels and shopping based on price. In addition, the control over the reservation price is partially transferred to competing hotels (their pricing decisions will directly influence the prices of the already confirmed bookings for a particular hotel). That's why Type III guarantee is rarely applied in practice. However, it might give customers greater confidence in their booking decision than the Type I guarantee.

✓ *Type IV guarantee* goes even further than Type III guarantee. It extends the period of validity of the guarantee to the whole period between the booking date and the check-in date. From financial and marketing points of view, this guarantee is the best for the customer but presents the highest risk for the hotel due to the uncertainty of the pricing actions of competing hotels. That's why, to the author's best knowledge, Type IV guarantee is not applied in practice.

Figure 11.2 below illustrates the application of all four types of lowest price guarantee. The customer makes a booking at price level  $P_0$ . If the benchmark price (the price of the same or similar hotel) drops to  $P_1$  during the 24-hour window and to  $P_2$  after that, the customer will pay price  $P_1$  if he is given Type I or Type III guarantee, and  $P_2$  if he is given Type II or Type IV guarantee.

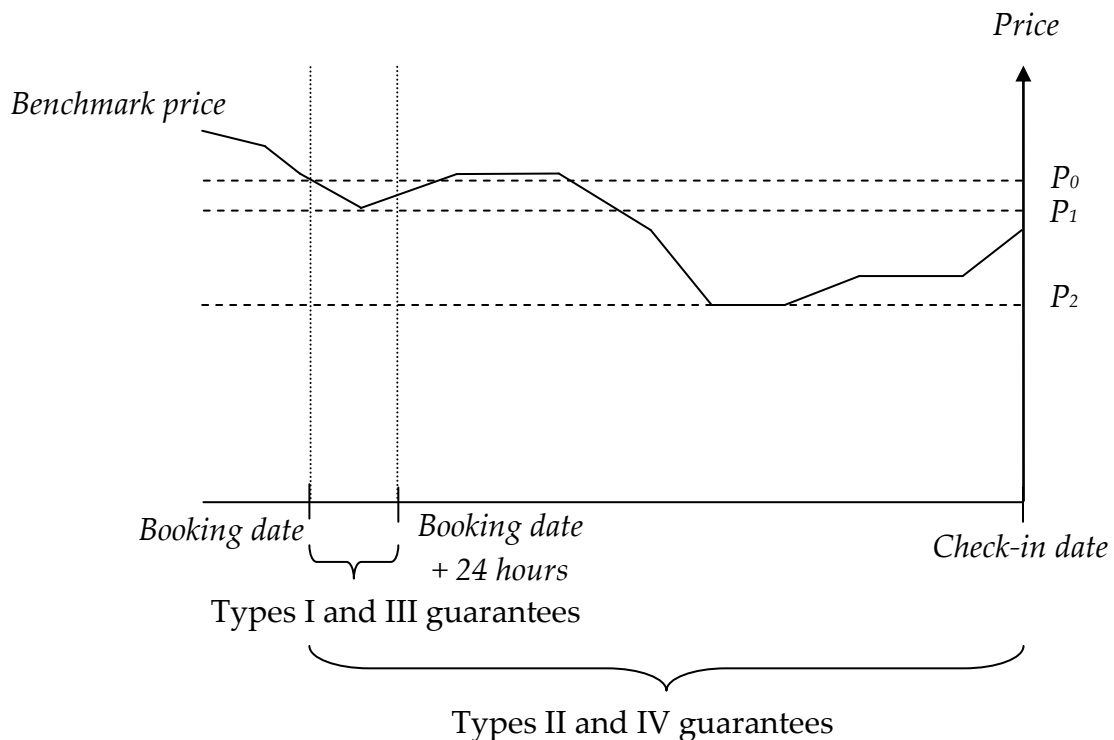

**Figure 11.2.** *Impact of lowest price guarantee validity on booking price*

### *Price presentation (price framing)*

Price framing refers to the way a price is presented to the customers. A lower price may be presented either directly as a low price or as a discount from a higher price. These concepts are different because they form a different expectation about the value of the product. In the value framework of hotel selection (Figure 10.1), the higher price serves as a reference price signalling greater gross value of the product (EGV), while the discount signals the financial benefits the customer will gain from booking now at the hotel (lower expected costs). When the price is not framed in the form of a discount, customers have to use the prices of competing hotels as a benchmark to form perceptions about the level of the price. Therefore, from a revenue management perspective, framing the low price as a discount from a higher price is preferable (see also Wirtz & Kimes, 2007). However, pricing research indicates that discounting in general might not have a significant long-term effect on hotel's financial performance (Croes & Semrad, 2012a, b) as the decrease in the prices may not be compensated by a respective increase in occupancy. In this regard Enz, Canina & Lomanno (2004) propose that hotels even keep their rates at normal levels when competitors are offering discounts.

### *11.4. General pricing strategies*

A hotel may apply various pricing strategies as summarised in Table 11.4 below. The specific strategic choice will depend on the type of accommodation establishment, its product and offered services, revenue management goals, competition and other pricing factors elaborated in Table 11.2.

**Table 11.4.** *Summary of general pricing strategies*

<b>General pricing strategy</b>	<b>Explanation</b>
<i>Demand (value) based pricing</i>	A hotel sets higher prices for market segments with higher willingness to pay, lower price elasticity and higher perceptions of product's value. This is consistent with the RM goal of revenue maximisation but might cause dissatisfaction among customers entitled to pay higher prices.
<i>Cost based pricing</i>	Price is set on the basis of costs – fixed and variable. It is easy to apply and comprehend but not related to the market factors and demand.
<i>Market penetration pricing</i>	Setting a low price for a limited period of time for newly opened accommodation establishments in order to attract demand. Applied also by existing properties when they aim at expanding their market share in a specific market segment.
<i>Market skimming pricing</i>	Opposite of market penetration pricing – setting a high price in order to capture the high demand for a novel product.
<i>Product bundle pricing</i>	Selling two or more services as a package at a single price – e.g. spa

General pricing strategy	Explanation
	hotels offering packages with accommodation, food and some spa procedures. The goal is to stimulate the consumption of additional services in the hotel. The price of the package should be lower than the sum of the prices of individual services included in the package.
<i>Optional product pricing</i>	The basic price includes accommodation only or accommodation and breakfast. All other services are paid for separately. Most widely applied pricing strategy.
<i>Psychological pricing</i>	Considers the psychological influence of numbers. For example, prices ending at 9 (e.g. 99) are considered as promotional, while prices ending at 0 (100) communicate value (see also (Collins & Parsa, 2006).
<i>Promotional pricing</i>	Temporarily lowering of prices in order to be more price competitive and attract bookings. The key point is that lower prices are valid for a limited period of time.
<i>Captive product pricing</i>	Applied when consumption of two or more products is interconnected (e.g. printer and cartridge). The company sets a high price on one product and a lower on the other – e.g. low price for the accommodation and high prices for additional services (golf, tennis, spa and wellness services, etc.)

### 11.5. 3D pricing model

Pricing is a complicated process and many factors need to be taken into account. This book proposes a 3D-pricing model that may be used by accommodation establishments when determining their prices, which is graphically depicted on Figure 11.3. The 3D-pricing model has three dimensions (hence its name):

✓ *Length* – price seasonality, i.e. prices vary depending on the period of stay. Price seasonality depends on the type of accommodation establishment, its product, category, served market segments, its geographic destination. Leisure hotels located in mass tourist destinations establish many seasons (periods of validity of their rates) with highest prices during the main tourist season and lowest prices during off-season periods. On the other hand, more hotel services and higher star ratings are associated with fewer seasonal variations in hotel prices (Espinet *et al.*, 2012).

✓ *Depth* – price levels according to the distribution channels. Hotels establish different rates for different distribution channels – direct sales, Global Distribution Systems, online travel agencies, tour operators, travel agents, group buying websites (see more details in Chapter 13).

✓ *Width* – the hotel establishes different prices for different booking terms.

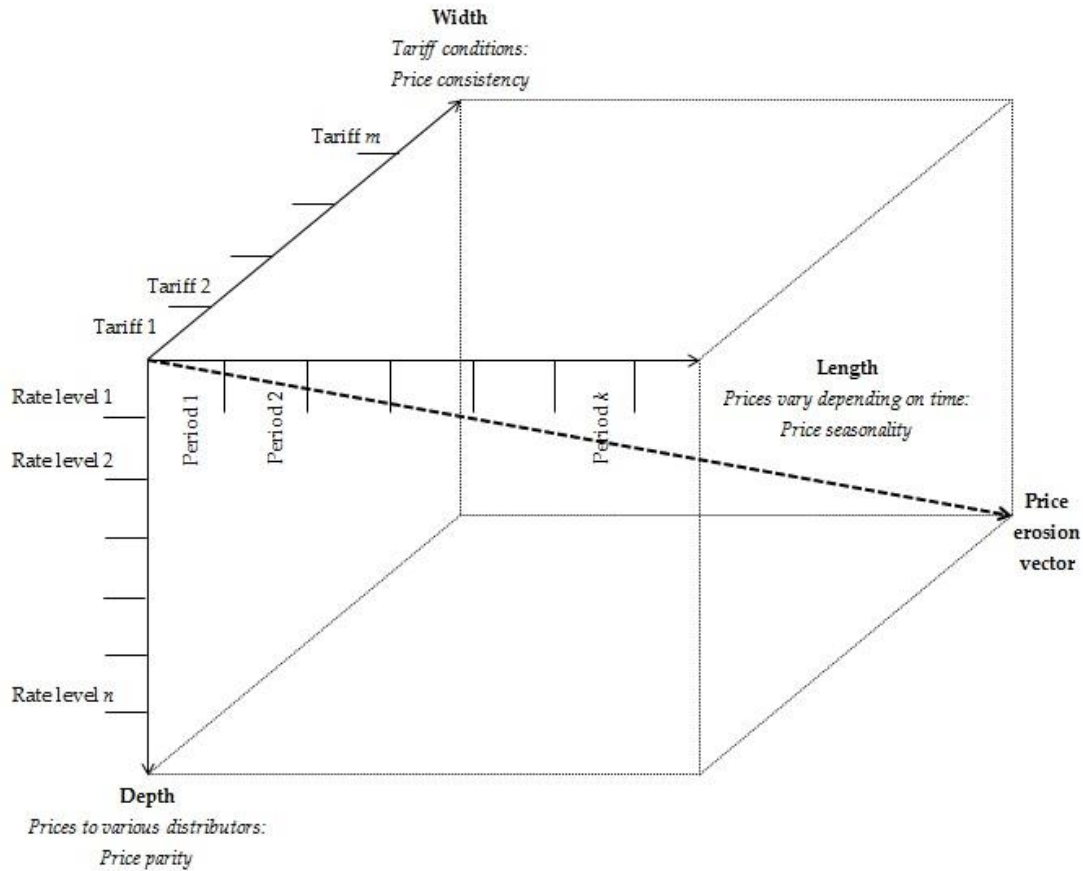
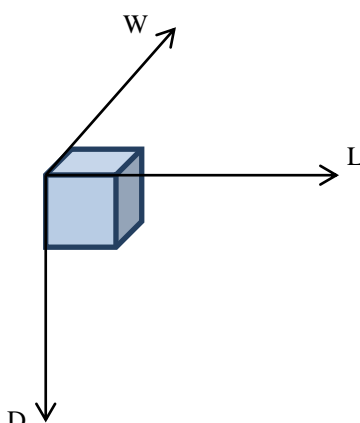
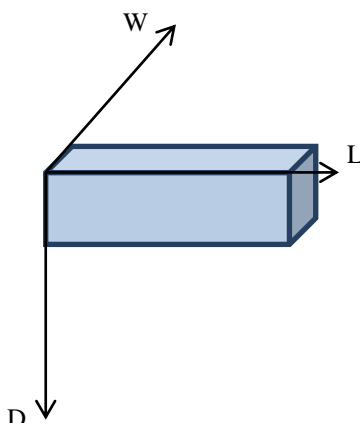

**Figure 11.3.** 3D-pricing model (author's elaboration)

The three dimensions form a 3D coordinate system. If the price decreases from *Period 1* to *Period k*, from *Price level 1* to *Price level n* and from *Tariff 1* to *Tariff m*, then the price will be highest at point (*Period 1; Price level 1; Tariff 1*) and lowest at point (*Period k; Price level n; Tariff m*). The vector connecting these two points we name 'price erosion vector' and it shows the direction of the decrease in room rates of the hotel. The specific combination of length, depth and width define several types of pricing strategies in the 3D pricing model graphically illustrated and explained in Table 11.5. Strategies vary from a *basic pricing strategy* (one season, one tariff, one price for all distributors) to a *full-scale/mature pricing strategy* (many seasons, many tariffs, many rate levels for distributors). They also have different applicability in the hotel industry. Most widely used are the basic, L-, LD-, LW- and mature pricing strategies, while D-, W- and WD- strategies have more limited application due to the importance of seasonality in pricing the hotel product. The main advantage of the 3D pricing model is that it provides a conceptual ground for the comparison and analysis of various pricing strategies applied by the accommodation establishments. It may be

further used by individual properties to benchmark their pricing strategies with competitors' and compare the number of seasons, tariffs and rate levels by distributor.

**Table 11.5.** *Theoretical types of pricing strategies in the 3D pricing model*

<i>Strategy type:</i>	<b>Basic strategy</b>
<i>Length:</i>	One season
<i>Width:</i>	One tariff
<i>Depth:</i>	One price for all distributors
<i>Graphical visualisation:</i>	
<i>Example:</i>	Guest houses, dormitories
<i>Strategy type:</i>	<b>L-strategy (long strategy)</b>
<i>Length:</i>	Prices vary throughout the year (seasonal pricing)
<i>Width:</i>	One tariff
<i>Depth:</i>	One price for all distributors
<i>Graphical visualisation:</i>	
<i>Example:</i>	Guest houses; hotels selling only directly or via OTAs

---

*Strategy type:* **D-strategy (deep strategy)**  
*Length:* One season  
*Width:* One tariff  
*Depth:* Prices vary by distributor  
*Graphical visualisation:*

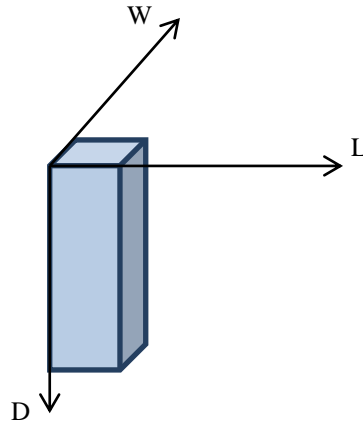

*Example:* Guest houses or family hotels working with tour operators

---

*Strategy type:* **W-strategy (wide strategy)**  
*Length:* One season  
*Width:* Many tariffs depending on purchase conditions  
*Depth:* Same price for all distributors  
*Graphical visualisation:*

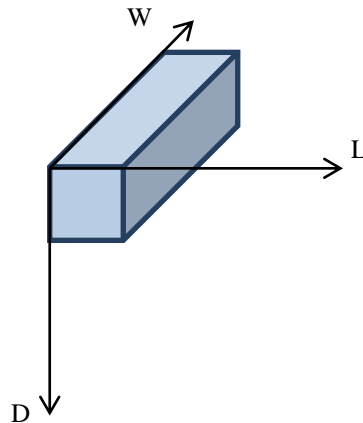

*Example:* A hotel selling only directly or via OTAs and differentiating room rates only on the basis of booking terms – e.g. with or without free cancellation.

---



---

<i>Strategy type:</i>	<b>LD-strategy</b>
<i>Length:</i>	Prices vary throughout the year (seasonal pricing)
<i>Width:</i>	One tariff
<i>Depth:</i>	Prices vary by distributor
<i>Graphical visualisation:</i>	

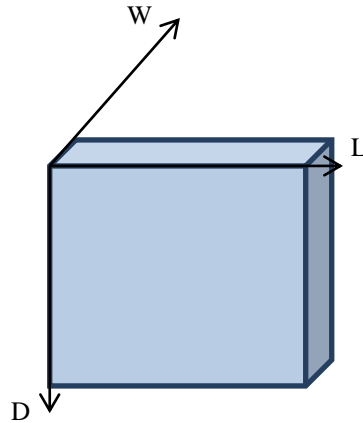

<i>Example:</i>	Most accommodation establishments
-----------------	-----------------------------------

---

<i>Strategy type:</i>	<b>LW-strategy</b>
<i>Length:</i>	Prices vary throughout the year (seasonal pricing)
<i>Width:</i>	Many tariffs
<i>Depth:</i>	Same price for all distributors
<i>Graphical visualisation:</i>	

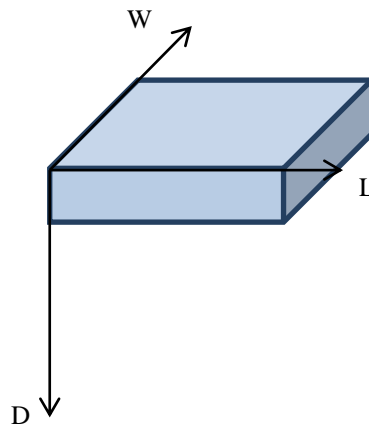

<i>Example:</i>	A hotel selling only directly or via OTAs with seasonal prices and differentiating room rates on the basis of booking terms (e.g. with or without free cancellation)
-----------------	--

---

---

*Strategy type:* **WD-strategy**  
*Length:* One season  
*Width:* Many tariffs  
*Depth:* Prices vary by distributor  
*Graphical visualisation:*

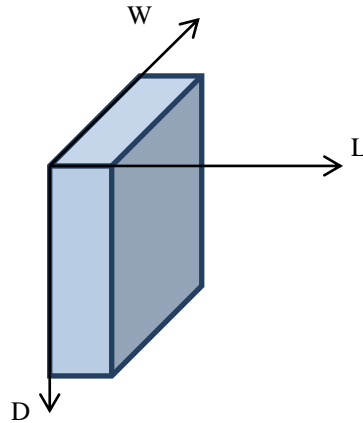

*Example:* A hotel working with different distributors and differentiating room rates only on the basis of booking terms

---

*Strategy type:* **Full-scale / Mature pricing strategy**  
*Length:* Prices vary throughout the year (seasonal pricing)  
*Width:* Many tariffs  
*Depth:* Prices vary by distributor  
*Graphical visualisation:*

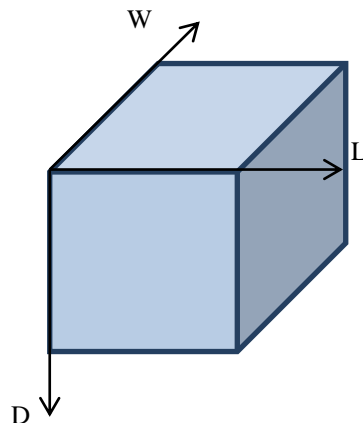

*Example:* Global hotel chains

---

## Chapter 12

### NON-PRICING HOTEL REVENUE MANAGEMENT TOOLS

In this chapter we shall concentrate on the non-pricing RM tools used in the Rooms Division of a hotel – the application of these tools in other departments of the hotel will be discussed in Chapter 14. Non-pricing revenue management tools concentrate on inventory management (i.e. the quantity of supply) and include capacity management, overcontracting and overbookings, room availability guarantee, length-of-stay control, and 100% satisfaction guarantee (see Figure 1.1.). Capacity management and overbookings are the two most influential techniques and, at the same time, the most controversial issues in revenue management (Karaesmen & van Ryzin, 2004).

#### *12.1. Capacity management*

Capacity management refers to the set of activities dedicated to a hotel's capacity control. Pullman & Rogers (2010) distinguish between strategic and short-term (tactical) capacity management decisions. The first include capacity expansion (e.g. number of rooms), carrying capacity (the optimal use of physical capacity before tourist's experience deteriorates, e.g. optimal occupancy rate), and capacity flexibility (a hotel's ability to respond to fluctuations in demand by changing its capacity by closing or opening wings/floors). Tactical decisions refer to the set of activities related to managing capacity on a daily basis – work schedules, guest arrival/departure times, service interaction time, application of queuing and linear programming models to service processes, customers' participation in the service process, etc.

From a narrow perspective, a hotel's capacity refers to the Rooms Division capacity only, i.e. the total number of overnights a hotel can serve on any given date (so called '*available room capacity*'). Due to various reasons (facility repairs or damage, accommodation of employees, etc.), some of the rooms may not be available for a particular date. That's why the available capacity of a hotel may vary on a daily basis

by a few rooms. A hotel can efficiently decrease its available room capacity (and save some fixed costs) by closing wings or floors, or expand it (and increase its revenue base) by offering day-let rooms, but in any case, room capacity has very limited flexibility as defined by Pullman & Rogers (2010). From a wider perspective, a hotel's capacity also includes the capacity of F&B outlets, golf course, function rooms and other revenue centres that provide greater options for capacity management. This will be analysed in the next chapter.

### 12.2. *Overcontracting and overbooking*

*Overcontracting* refers to the signing of contracts with distributors (GDSs, OTAs, tour operators, travel agents, etc.) for a greater number of rooms than the physical capacity of the hotel. Overcontracting is necessary because distributors do not utilise their entire allotments in hotels. Tour operators, for example, contract more rooms in hotels at a destination than the number of seats they have in (charter) flights in order to have greater flexibility and choice of accommodation establishments for their customers. However, such opportunistic behaviour from their side puts hotels in a vulnerable position where they are not sure whether the contracts with the tour operators will be fulfilled, or what percentage of the contracted rooms will effectively be booked and used by them. To protect themselves, *hotels fight overcontracting by tour operators with overcontracting on their side*. This is especially valid for seaside properties at mass tourism destinations where hotels are largely perceived as substitutable and their product is commoditised.

*Overbooking* relates to confirming to distributors and direct customers bookings for a greater number of rooms than the available capacity of the hotel. It is based on the assumption that some customers that have booked rooms will not appear for check-in (so called 'no show'), others will cancel or amend their bookings at the last minute, while still others will prematurely break their stay in the hotel (due to illness, personal reasons, traffic, bad weather, force majeure, or other reasons). To protect itself from losses the hotel confirms more rooms than its available room capacity with the expectation that the number of overbooked rooms will match the number of no shows, last minute cancellations and amendments. Overcontracting and overbooking as RM tools are closely connected as shown on Figure 12.1.

Section *A* on Figure 12.1 depicts the available room capacity of the hotel for a particular date. The sum of all sections  $A+B+C+D$  is the total number of contracted rooms, i.e. the sum of all allotments of distributors in the hotel for a given date. The difference between the contracted rooms and the available room capacity defines the *overcontracted rooms* ( $B+C+D$ ). The sum of sections  $A+B+C$  illustrates the number of rooms for which the hotel has received booking requests, leaving section *D* as the contracted but unrequested rooms. Some booking requests will be confirmed ( $A+B$ ) while others will not be granted (section *C*). The number of rooms (*B*) confirmed above the available room capacity defines the number of overbooked rooms.

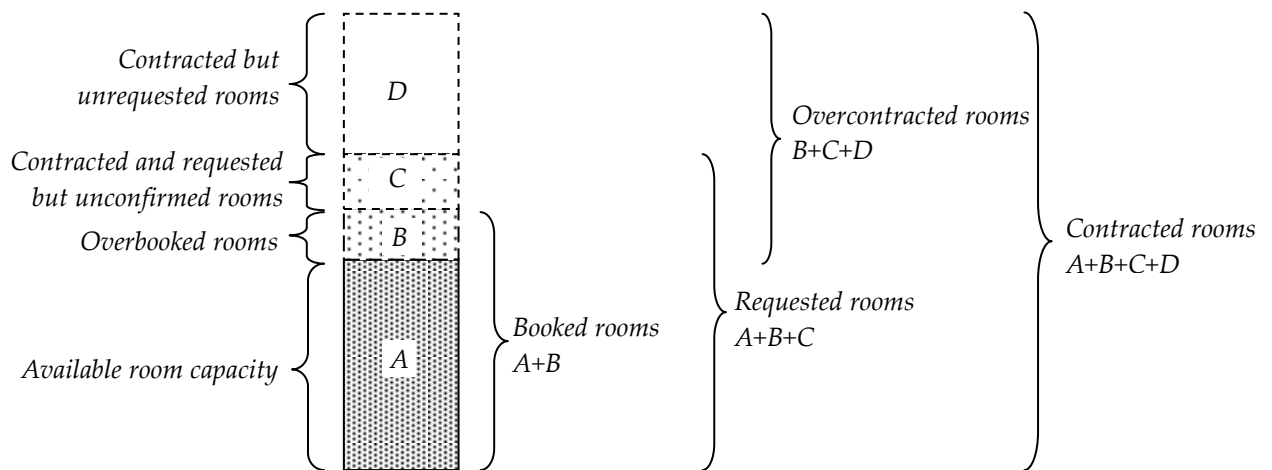

**Figure 12.1.** Relationship between overcontracting and overbooking of rooms

Overbookings are a widely analysed tool (Talluri & van Ryzin, 2005; Chiang *et al.*, 2007; Lan, Ball & Karaesmen, 2007), also in the framework of the hotel industry (Badinelli, 2000; Bitran & Mondschein, 1995; Guadix *et al.*, 2010; Ivanov, 2006, 2007a, 2014; Koide & Ishii, 2005; Netessine & Shumsky, 2002; Pullman & Rogers, 2010; Toh & de Kay, 2002; Tranter, Stuart-Hill & Parker, 2008). The great interest in management of overbookings is entirely justified because of the criticism overbooking policies receive, especially in its legal and ethical considerations, elaborated further in Chapter 15.

When managed properly, overbookings do not ordinarily cause serious problems. If, for instance, a hotel has confirmed *X* rooms on top of its available room capacity and the customers for the same number of rooms do not arrive for check-in, then the number of occupied rooms for this particular date will be equal to the available room

capacity of the hotel and the total room revenues from overnights, *ceteris paribus*, will be at maximum. However, if no shows, last-minute cancellations and amendments are fewer than the number of the overbookings (more customers arrive for check-in than the available room capacity), some of the guests will not be accommodated and should be walked to other hotels which thus incurs overbooking costs for the hotel. Overbooking costs have two elements: *a) direct financial expenses* for walking the guests to another property (cost of accommodation in the alternative hotel, transportation of guests to it, compensation for inconveniences caused); and *b) brand image (customer goodwill) losses* due to the walking of guests. While the former are easy to calculate, the latter are more important for the long-term relationships of the hotel with its customers, yet more difficult to calculate. On the other hand, if the number of no shows, last-minute cancellations and amendments is greater than the number of overbookings, part of the available capacity of the hotel remains unoccupied and it loses revenues. Lost revenue from non-guaranteed reservations equals the room rate, while lost revenue from guaranteed bookings is lower and equals the room rate deducted with the cancellation charges. Therefore, hotels must plan carefully the *optimal level of overbookings* (Hadjinicola & Panayi, 1997; Ivanov, 2006, 2007, 2014; Koide & Ishii, 2005; Netessine & Shumsky, 2002). Netessine and Shumsky (2002: 39) indicate that the optimal overbooking level balances the lost revenue from empty rooms with the overbooking costs. Appendices 12.1, 12.2 and 12.3 elaborate the mathematical models for calculating the optimal overbooking levels for one-, two- and three-room type hotels using the expected marginal room revenue technique.

Regardless how well a hotel plans its optimal level of overbookings, differences between planned and actual number of no shows, last-minute cancellations and amendments are inevitable. When more guests appear for check-in, the hotel must walk some of them to a different property. This requires the front office manager to make several decisions about walking guests (Baker, Bradley & Huyton, 1994; Ivanov, 2006):

✓ *Who to be walked?*

A suitable approach is to accommodate guests on a 'first come-first served' basis and walking late arrivals to other hotels. This approach, however, does not take into

account the different importance of hotel's customers. The front office manager should also consider:

- *Length-of-stay* – guests with shorter stays (one night) could be walked instead of those with longer stays. Resort hotels could offer to already accommodated guests to spend their last night at a luxury airport hotel for free (Wirtz *et al.*, 2003: 224).

- *Guests' loyalty* – walking a regular customer might incur more negative impacts than a first-comer. Therefore they should be walked last.

- *Room rate* – usually hotels walk guests who have paid the lowest rates. This means that hotels prefer to accommodate direct customers at the expense of those sent by tour operators and travel agents. Such an approach, although financially sound in the short-run, might cause the termination of the contract between the hotel and the tour operator/travel agent in the long-run, especially if the hotel regularly walks guests of tour operators and travel agents (Kotler, Bowen, Makens, 2006).

✓ *Where to walk guests?*

A hotel must redirect its guests to another establishment of the same or higher category. If this is impossible (there is no other similar hotel in the city/resort or no rooms are available), overbooked guests could be walked to a hotel of a lower category but they must receive a refund equal to the price difference between the two hotels. To face the overbooking situation prepared, it is recommended that the hotel has a contract (or at least a verbal agreement) with two or three other hotels in the area to which guests will be walked. The reverse situation is also possible – if other hotels are overbooked the hotel in question might receive bookings (and revenues!) from them provided rooms are available. Therefore, *each hotelier must keep good relationships with managers of competing hotels, because it is they who will help in case of a serious overbooking.*

At the practical level, hotel managers are required to establish service recovery programmes with standard procedures to be followed by their front office managers if they find that too many rooms have been overbooked. Baker, Bradley & Huyton (1994: 131-132) propose a detailed multi-step procedure for the front office manager:

- Define the number of booked rooms.
- Check the arrivals list, types of bookings (guaranteed or nonguaranteed), booking remarks and room status to identify possible late or early departures, no

shows, last-minute cancellations and amendments. This will show how many rooms are expected to be occupied for the particular date.

- Compare the number of booked rooms and the number of rooms expected to be occupied – the difference between them shows the excessive overbooking and the potential number of guests that need to be walked.

- Search for internal sources to increase available capacity of the hotel to accommodate guests – different room type in the same hotel (upgrade/downgrade), rooms used by hotel employees.

- Book necessary rooms in an alternate hotel in nearest vicinity.

- Decide who to walk.

- Arrange transportation to the alternative hotel and compensation for the inconvenience.

- Inform the general manager, revenue manager and everyone concerned in the hotel.

✓ *What compensation to provide?*

Obviously, when a guest is denied service and must be walked to another property, he has to receive monetary or non-monetary compensation, e.g. direct cash refund, complimentary meal, a free voucher for a spa centre or casino, bottle of wine/champagne, or other gift. The form of compensation is directly linked with the satisfaction level. Noone & Lee (2011) explain that cash-based overcompensation results in significantly higher satisfaction than normal compensation or voucher-based compensation.

Looking at the booking curve for a particular date (see Figure 8.3), the revenue manager might decide that the number of accrued bookings for that date is high enough and no more bookings should be confirmed. In this situation, the revenue manager has potentially two options:

- ✓ *Option 1:* Close the date for sale and inform the distributors about the closed date.

- ✓ *Option 2:* Do not close the date but increase the price significantly (e.g. 2-4 times above the normal rate – called '*prohibitive price*'). The aim is to deter bookings for that particular date but not close the date for sale, i.e. the hotel will show availability in GDSs, OTAs, and other hotel reservation systems. If, however, the demand is very high and there are sales at this high price, then the front office



manager may walk guests to alternative hotels with the lower prices (or on the basis of other possible criteria).

Obviously, the second option provides greater flexibility but hoteliers risk creating an image of a too-expensive property. It is possible that customers are dissuaded from making future bookings at the hotel (even at normal rates) due to their perceptions of it being too expensive. However, the opposite situation is also possible – the normal rates for the hotel being perceived as bargain prices compared to the prohibitive price. Further research is needed in this field to understand the reaction of potential customers to such price dynamics as no definite answer may yet be given from a theoretical perspective. In any case, great care must be taken when prohibitive pricing is applied.

### *12.3. Room availability guarantee*

Walking guests with confirmed bookings to another hotel creates stress for them and loss of brand image/customer goodwill for the hotel. To eliminate their perceived risk from potential overbooking, hotel chains provide a *room availability guarantee* to selected guests (e.g. members of a loyalty programme) according to which guests will be accommodated in the hotel, regardless of its occupancy rate, provided the guests made the booking a certain minimum number of days before check-in. Intercontinental Hotel Group, for instance, gives a room availability guarantee to its Platinum Elite Rewards Club members subject to the following conditions (IHG, 2014):

- Requires 72 hours advance notice.
- Platinum Elite members are guaranteed one guest room for personal use for reservations made at least 72 hours prior to the date of arrival, except during special events that result in extraordinary demand, as determined solely by the hotel.
- Guaranteed room availability is not valid for Reward Nights.
- These reservations can only be made through the IHG Rewards Club Service Center.

Room availability guarantee does not result in direct revenues for the hotel but it decreases the perceived risk for the guest. It is not provided to all guests because walking guests in case of an overbooking then becomes impossible – the hotel cannot walk guests with a room availability guarantee.

#### *12.4. Length-of-stay control*

Length-of-stay control is a much neglected area of research (Ismail, 2002; Kimes & Chase, 1998; Vinod, 2004), yet widely applied in hotel business practice. Through it, hotels set limits on the minimum and, rarely, maximum number of nights in the customer bookings. Length-of-stay control allows hotels to protect themselves from losing revenues when customers book rooms for short stays in periods of huge demand (e.g. during special events such as exhibitions, fairs, congresses, sport events, etc.). It also provides the possibility to generate additional revenues from overnights in days when demand is historically low (e.g. when a business hotel requires compulsory stay over Saturday nights for all bookings that include a Friday night). Vinod (2004) highlights that length-of-stay control has one major disadvantage – it is static and, therefore, not very flexible. In practice, limitation on the length-of-stay should be explicitly stated in the pricing section of hotel's website and hotel rate's conditions in OTAs'/GDSs'/tour operators' websites. However, it is also possible that the length-of-stay is not explicitly stated but implied – this is the case when the hotel does not appear at all in the list of hotels in the OTAs'/GDSs'/tour operators' websites for booking requests for stays shorter than the minimum required number of overnights during a particular period. The maximum length of stay is very rarely used by hotels – usually when a hotel would be closed after a particular date due to the start of renovation works or the end of the season.

Length-of-stay control may be successfully implemented only if it is applied by most of the hotels at a destination during a given period. If, for example, only a handful of properties out of many hotels available require that guests spend a minimum number of nights during a particular period of time, they will not be competitive because potential customers would very easily find and book rooms in properties that do not impose such limitations. Cooperation among hotels at a destination proves, again, to be a prerequisite for successful revenue management.

#### *12.5. 100% Satisfaction guarantee*

A service guarantee promises the customer that if the service delivery system does not meet certain performance standards, he is entitled to an economic and/or noneconomic payout (Baker & Collier, 2005: 197). Some hotel chains like Hampton Inn (Hampton Inn, 2014) provide their customers a 100% satisfaction guarantee. If

guests are not completely satisfied with their stay, they do not pay for it. However, in order to protect the financial interests of the chain and dissuade opportunistic behaviour of some customers, this guarantee may be used by a customer only once. The idea behind this limitation is that, if a customer is really dissatisfied and wants a refund, he would not make a booking in the same hotel chain again. If, however, he does this it means that the previous time he wasn't entirely dissatisfied but wanted to take advantage of the guarantee. That's why when he makes a booking in any hotel of the chain *after* the guarantee has been used, the customer is explicitly advised in writing that he cannot be provided a 100% satisfaction guarantee. Considering its serious financial implications and relatively low loyalty of customers to particular hotels, this guarantee is not feasible for application by individual properties but by chains only. The 100% satisfaction guarantee does not directly increase the revenues of a hotel, but decreases the risk perceived by the customer in his choice of an accommodation establishment (see Chapter 10).

## Appendix 12.1. *The basic model of overbookings*<sup>1</sup>

This appendix presents the derivation of the optimal number of overbooked rooms by applying the expected marginal room revenue technique (Ivanov, 2006; Netessine & Shumsky, 2002).

Let the random variable  $X$  be the number of rooms of guests, holding confirmed bookings for a specific date, that do not arrive at the hotel (no shows, last minute cancellations, last minute amendments of reservations of already accommodated guests). For simplicity we assume that the hotel sells all its rooms at one rate  $r$  (in Appendices 12.2 and 12.3 this assumption would be removed and the situation of two and three types of rooms would be analysed, respectively). If the hotel sells all its rooms without overbookings, but guests for  $X^*$  rooms do not arrive, the hotel will have missed revenues of  $X^*.r$ . Therefore the hotel can increase its revenues if it confirms  $X^*$  rooms above its available capacity. If the guests for  $X^*$  rooms do not arrive the number of the occupied rooms will be equal to its available capacity and the total revenues  $TR$  will be maximum.

If the actual number of last minute cancellations, amendments and no shows is  $X_1 < X^*$ , the number of rooms of guests holding confirmed bookings is greater than the available capacity of the hotel and some of them ( $X^* - X_1$ ) should be walked to other hotels, for which the hotel incurs overbookings costs  $c$  per room/night, or total  $c.(X^* - X_1)$ . If the last minute cancellations, amendments and no shows are  $X^* < X_2$ , the hotel will have missed revenues of  $r.(X_2 - X^*)$  although less than compared with the situation without overbookings.

In order to calculate the optimal number of overbookings  $X^*$ , we must define the marginal revenues  $MR_{ob}$  and marginal cost  $MC_{ob}$  associated with the overbookings. Let  $F(X)$  be the distribution function of  $X$ , showing the probability of guests holding confirmed bookings for  $X$  number of rooms that do not arrive at the hotel and their rooms remain unoccupied. The total costs of the overbookings  $TC_{ob}$  include the net costs and missed revenues. There are two possible situations:

---

<sup>1</sup> Some of the text and the formulas in this appendix have been adapted from Ivanov (2006) with the permission of the publisher

- ✓ If  $X \leq X^*$ ,  $TC_{ob}(X \leq X^*) = c \cdot F(X) \cdot (X^* - X)$
- ✓ If  $X^* < X$ ,  $TC_{ob}(X^* < X) = r \cdot [1 - F(X)] \cdot (X - X^*)$

Therefore, the total costs of overbookings  $TC_{ob}$  are:

$$(1) TC_{ob} = TC_{ob}(X \leq X^*) + TC_{ob}(X^* < X) = c \cdot F(X) \cdot (X^* - X) + r \cdot [1 - F(X)] \cdot (X - X^*)$$

Marginal costs of the overbookings  $MC_{ob}$  are found through differentiating (1):

$$(2) MC_{ob} = \frac{\partial TC_{ob}}{\partial X} = r \cdot [1 - F(X)] - c \cdot F(X)$$

On the other hand, the hotel does not receive any revenues from the unoccupied rooms, as well as from walking guests to other hotels due to overbookings (this assumption would be removed later in this appendix). Thus, its marginal revenues are null:

$$(3) MR_{ob} = 0$$

The hotel can afford to overbook until the marginal revenues from the overbookings exceed the marginal costs from them:

$$(4) MC_{ob} \leq MR_{ob}$$

In microeconomic analysis total revenues are maximum when  $MR=MC$ , but because we look for an integer solution, the equation may not be kept. Substituting (2) and (3) in (4) leads to:

$$(5) r \cdot [1 - F(X)] - c \cdot F(X) \leq 0$$

$$(6) r - r \cdot F(X) - c \cdot F(X) \leq 0$$

$$(7) r \cdot F(X) + c \cdot F(X) \geq r$$

$$(8) F(X) \geq \frac{r}{r+c}$$

The optimal number of overbookings  $X^*$  is the smallest integer for which inequality (8) is fulfilled (Ivanov, 2006; Netessine & Shumsky, 2002).

Inequality (8) may be illustrated with the following empirical example:

*Example 12.1:* Let a hotel have a capacity of 230 rooms. The revenue manager finds that the number of last-minute cancellations, amendments and no shows have a normal distribution with a mean  $\bar{X} = 10$  rooms and a standard deviation  $\sigma=7.5$  rooms. The price of one room at the hotel is  $r=130$  EUR and the net costs of walking a guest are  $c=165$  EUR. Substituting the initial data in (8) we get:

$$(9) F(X) \geq \frac{130}{130+165} = 0.4407$$

With the help of Excel through the function “=NORMINV(0,4407;10;7,5)” we find that to  $\bar{X} = 10$ ,  $\sigma=7.5$  and  $F(X)=0.4407$  corresponds  $X=8.88104$ . Therefore, the optimal number of overbookings is  $X^* = 9$  rooms, and the maximum number of confirmed bookings for a particular date should not exceed  $230+9=239$  rooms. Of course, in practice the statistical distribution of  $X$  for a particular hotel might not be normal but some other type and this other type of distribution should be used in the calculation of  $X^*$ .

#### *Additional considerations of the basic model*

1. The basic mathematical model assumes that a hotel offers all its rooms at only one rate, which will not be the case in reality. As discussed in details in Chapter 11, hotels differentiate room rates on the basis of kind of room (single, double, triple), type of room (standard, deluxe, studio, suite, apartment), days of the week, market segments, market intermediaries etc. This complicates the price structure and calculation of the optimal number of overbookings. Appendix 12.2 overcomes this weakness of the basic model by elaborating the optimal overbooking limits for a hotel with two room types, while Appendix 12.3 illustrates the case of a 3-room type hotel.
2. Some hotels have a joint reservation policy with other hotels belonging to the same owners – they act as one hotel, have the same rates and guests are accommodated at any of them (they learn the name of the exact hotel at the day of arrival). The Hotels Center 1, Center 2 and Center 3 in Rome are an excellent example (<http://www.centerhotelrome.com>). In this situation, we must calculate a joint optimal number of overbookings for the participating hotels which might be different

from the sum of the separate optimal numbers. For simplicity we shall examine the situation of two hotels, but it is easily generalisable for three and more hotels.

Let  $X_1$  be the discrete random variable of last-minute cancellations, amendments and no shows at the first hotel. Its specific values are  $X_{1i}$  with probabilities  $P(X_{1i})$  and cumulative probabilities  $F(X_{1i}) = \sum_{k=1}^i P(X_{1k})$ . We denote with  $X_2$  the discrete random variable of last-minute cancellations, amendments and no shows at the second hotel. Its specific values are  $X_{2i}$  with probabilities  $P(X_{2i})$  and cumulative probabilities  $F(X_{2j}) = \sum_{m=1}^j P(X_{2m})$ .

The joint discrete random variable of last-minute cancellations, amendments and no shows at both hotels is  $X = X_1 + X_2$ . Its specific values are  $X_n \in [\min\{X_{1i}; X_{2j}\}; \max\{X_{1i}\} + \max\{X_{2j}\}]$ . The probabilities are:

$$(17) P(X_n) = \sum_i \sum_j P(X_{1i}) \cdot P(X_{2j}), \forall i, j: X_{1i} + X_{2j} = X_n$$

The cumulative probabilities of  $X$  are:

$$(18) F(X_n) = \sum_{s=1}^n P(X_s)$$

The total optimal number of overbookings for both hotels  $X^*$  is the smallest integer for which inequality (8) is fulfilled, given the cumulative probabilities of (17). It can be greater, equal to or less than the sum of the separate optimal numbers  $X_1^* + X_2^*$  [(see Ivanov (2006) for illustrative examples)].

3. The basic model assumes that the marginal revenue from the unoccupied room is null (see Equation (3) in this Appendix). While this is valid for non-guaranteed bookings, in practice, hotels actually do receive some revenue  $m$  in the form of a cancellation charge in case of late cancellations of their guaranteed bookings. The total revenues from cancellation charges for the unoccupied rooms will be:

$$(19) TR_{ob}(X^* < X) = m \cdot [1 - F(X)] \cdot (X - X^*)$$

Differentiating (19) we find the marginal revenues of the unoccupied rooms to be:

$$(20) MR_{ob} = m. [1 - F(X)]$$

Substituting (20) in (4) leads to:

$$(21) r. [1 - F(X)] - c. F(X) \leq m. [1 - F(X)]$$

$$(22) F(X) \geq \frac{r-m}{r-m+c} = 1 - \frac{c}{r-m+c}$$

Inequality (22) is similar to (8) but, instead of  $r$  (room rate), it includes net lost revenue or the opportunity cost of not having overbooked the room – the difference between the room rate and the cancellation charge ( $r - m$ ). It also suggests that the *optimal level of overbookings is inversely related to the amount of the cancellation charge* – the closer the cancellation charge to the room rate, the lower the missed benefit from the unoccupied room, and the less the stimuli to overbook. If hotels accept both guaranteed and non-guaranteed bookings, then the optimal number of overbookings must be set separately for each booking type and will change depending on the ratio between the guaranteed and non-guaranteed bookings – see Ivanov (2007a) for a discussion of the issue.

4. The basic model disregards the lifetime value of the customer and the potential loss of future revenues, caused by the fact that guests with overbookings might not make future bookings at the same hotel. Walking customers to other properties influences their perceptions of service quality in the hotel they have initially booked and their patronage intentions. They might choose not book again at the particular hotel thus leading to loss of all future revenue generated by them. However, the uncertainty of the customer's lifetime value makes research of the issue quite complicated. The customer lifetime value is discussed in Chapter 15.

5. The statistical distribution of last-minute cancellations, amendments and no shows is influenced by special events – fairs, exhibitions, congresses, sport events, etc. During special events, the demand for hotel accommodation increases significantly, corresponding to a lower number of last-minute cancellations and no shows, which coupled with high occupancy rates and limiting the possibilities to walk guests, means that the optimal number of overbookings is very low, if not equal to zero.



## Appendix 12.2. Overbooking model for a two-room type hotel<sup>2</sup>

As mentioned in Appendix 12.1., the basic overbooking model disregards the fact that hotels have more than one type of room. When a hotel offers two or more types of rooms at different prices, then upgrades and downgrades become possible. This appendix deals with the mathematical model for overbookings in hotels with two types of rooms.

Let a hotel have two types of rooms: high priced (denoted with index  $H$ ) and low priced (denoted with index  $L$ ) and downgrade from  $H$  to  $L$  rooms and upgrade from  $L$  to  $H$  rooms are possible. Prices for the two room types are  $r_H$  and  $r_L$ , the costs for walking guests are  $c_H$  and  $c_L$ , the random variables of the no shows, late cancellations and amendments are  $X_H$  and  $X_L$  with distribution functions  $F(X_H)$  and  $F(X_L)$ , and the optimal numbers of overbookings are  $X_H^*$  and  $X_L^*$ . We have the following four situations summarised in Figure 12.2.1:

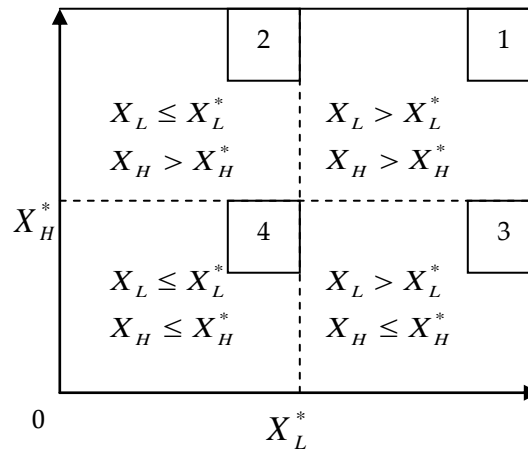

**Figure 12.2.1.** Possible situations of last-minute cancellations, amendments and no shows for a hotel with two types of rooms with different rates

In situations [1] and [2] last-minute cancellations, amendments and no shows for the more expensive rooms are higher than their optimal level ( $X_H > X_H^*$ ). The hotel misses revenues  $r_H \cdot [1 - F(X_H)] \cdot (X_H - X_H^*)$  in both cases from the unoccupied expensive rooms. In [1] the hotel also loses revenue from the unsold cheaper rooms  $r_L \cdot [1 - F(X_L)] \cdot (X_L - X_L^*)$ . In [2] some of the guests who have arrived with confirmed

<sup>2</sup> Some of the text, the figure and the formulas in this appendix have been adapted from Ivanov (2006) with the permission of the publisher

overbookings for the  $L$  rooms can be accommodated in the available  $H$  rooms causing a loss of revenues  $(r_H - r_L) \cdot F(X_L) \cdot (X_H - X_H^*)$ . The rest of the guests in [2] will be walked to another hotel incurring costs  $c_L \cdot F(X_L) \cdot (X_L^* - X_L - X_H + X_H^*)$ . The sum of the four elements of the costs and missed benefits gives the total costs of the overbookings given  $X_H > X_H^*$ :

$$(1) TC_{ob}(X_H > X_H^*) = r_H \cdot [1 - F(X_H)] \cdot (X_H - X_H^*) + r_L \cdot [1 - F(X_L)] \cdot (X_L - X_L^*) + (r_H - r_L) \cdot F(X_L) \cdot (X_H - X_H^*) + c_L \cdot F(X_L) \cdot (X_L^* - X_L - X_H + X_H^*)$$

In situations [3] and [4]  $X_H \leq X_H^*$  which causes costs of walking guests  $c_H \cdot F(X_H) \cdot (X_H^* - X_H)$  in both cases. In [4] this is combined with costs of walking guests with confirmed overbookings for the  $L$  rooms  $c_L \cdot F(X_L) \cdot (X_L^* - X_L)$ . In [3] some of the guests will be accommodated in the cheaper rooms, causing a refund  $(r_H - r_L) \cdot F(X_H) \cdot (X_L - X_L^*)$ . The rest of the guests will be walked to another hotel incurring costs  $c_H \cdot F(X_H) \cdot (X_H^* - X_H - X_L + X_L^*)$ . Thus, the total overbooking costs when  $X_H \leq X_H^*$  are:

$$(2) TC_{ob}(X_H \leq X_H^*) = c_H \cdot F(X_H) \cdot (X_H^* - X_H) + c_L \cdot F(X_L) \cdot (X_L^* - X_L) + (r_H - r_L) \cdot F(X_H) \cdot (X_L - X_L^*) + c_H \cdot F(X_H) \cdot (X_H^* - X_H - X_L + X_L^*)$$

The sum of (1) and (2) gives the total costs of the overbookings for both types of rooms:

$$(3) TC_{ob}(X_L; X_H) = TC_{ob}(X_H \leq X_H^*) + TC_{ob}(X_H > X_H^*) = r_H \cdot [1 - F(X_H)] \cdot (X_H - X_H^*) + r_L \cdot [1 - F(X_L)] \cdot (X_L - X_L^*) + (r_H - r_L) \cdot F(X_L) \cdot (X_H - X_H^*) + (r_H - r_L) \cdot F(X_H) \cdot (X_L - X_L^*) + c_H \cdot F(X_H) \cdot (X_H^* - X_H) + c_L \cdot F(X_L) \cdot (X_L^* - X_L) + c_L \cdot F(X_L) \cdot (X_L^* - X_L - X_H + X_H^*) + c_H \cdot F(X_H) \cdot (X_H^* - X_H - X_L + X_L^*)$$

Total costs  $TC_{ob}(X_L; X_H)$  are minimum when marginal costs of the overbookings are equal to the marginal revenues from them for both room types:

$$(4) \begin{cases} \frac{\partial TC_{ob}(X_L; X_H)}{\partial X_L} = 0 \\ \frac{\partial TC_{ob}(X_L; X_H)}{\partial X_H} = 0 \end{cases}$$

Substituting (3) in (4) and performing the mathematical operations leads to:

$$(5) \begin{cases} r_H - F(X_H) \cdot (r_H + 2c_H) - F(X_L) \cdot (r_L + c_L - r_H) = 0 \\ r_L - F(X_L) \cdot (r_L + 2c_L) - F(X_H) \cdot (r_L + c_H - r_H) = 0 \end{cases}$$

If  $F(X_L^0)$  and  $F(X_H^0)$  are solutions of (5) the optimal numbers of overbookings  $X_L^*$  and  $X_H^*$  are the smallest integers such that:

$$(6) \begin{cases} F(X_L^*) \geq F(X_L^0) \\ F(X_H^*) \geq F(X_H^0) \end{cases}$$

### Appendix 12.3. Overbooking model for a three-room type hotel<sup>3</sup>

This appendix focuses on optimal overbooking limits for a three-room type hotel with upgrade and downgrade constraints. Let a hotel have three types of rooms denoted as  $H$  (high-priced rooms),  $M$  (mid-priced) and  $L$  (low-priced) rooms. Their respective room rates are  $r_H$ ,  $r_M$  and  $r_L$ , such as:  $r_H > r_M > r_L$ . When overbooking happens and guests must be walked to another property, the hotel incurs overbooking costs  $c_H$ ,  $c_M$  and  $c_L$ , which fulfil the condition:  $c_H > c_M > c_L$ . The assumption is that overbooking costs are higher than the respective room rates, i.e.  $c_H > r_H$ ,  $c_M > r_M$  and  $c_L > r_L$  because the hotel incurs additional expenses for those guests (paying for the second hotel, transportation, free food vouchers, free bottle of wine, souvenirs/gifts, etc.) to compensate them for the inconveniences caused, and may therefore experience some brand image losses (see Appendix 12.1).

When the hotel does not overbook or has overbooked less than the optimal level and some rooms remain unoccupied, the hotel has missed benefits in the form of missed revenues which are equal to the respective room rates for those rooms –  $r_H$ ,  $r_M$  or  $r_L$  (for simplicity, we disregard the missed revenues from additional services in the hotel). We denote with  $X_H$ ,  $X_M$  and  $X_L$  the random variables of the number of confirmed  $H$ ,  $M$  and  $L$  rooms, respectively, for a specific date that remain unused due to no-shows, last-minute cancellations and amendments of reservations of already accommodated guests. Their respective distribution functions are  $F(X_H)$ ,  $F(X_M)$  and  $F(X_L)$ , showing the probabilities of guests holding confirmed bookings for  $X_H$ ,  $X_M$  and  $X_L$  number of rooms that do not arrive at the hotel and their rooms remain unoccupied. The optimal level of overbooking for each room type is denoted with  $X_H^*$ ,  $X_M^*$  and  $X_L^*$ .

We assume that *the demand for each room type is independent from the demand for the other 2 room types*, i.e. the market segments for the 3 room types are quite distinct. In practice, the customers for apartments and suites (high-priced rooms) will be different from the customers for business rooms (mid-priced rooms) and the guests in standard (low-priced) rooms. We further consider that an upgrade to a higher room category and downgrade to a lower category is possible, but with some limitations as presented by the following rules:

---

<sup>3</sup> For the full mathematical model and the derivation of the functions see Ivanov (2014)

*Rule 1:* An upgrade to a higher room category is acceptable but by one step only: we can upgrade  $L$  to  $M$  (denoted with  $L \rightarrow M$ ) and  $M \rightarrow H$ , but not  $L \rightarrow H$ , in order to avoid overcompensation of customers.

*Rule 2:* A downgrade to a lower room category is acceptable but by one step only: we can downgrade  $M$  to  $L$  (denoted with  $L \leftarrow M$ ) and  $M \leftarrow H$ , but not  $L \leftarrow H$ , in order to minimise the negative consequences from the downgrade.

*Rule 3:* A downgrade to a certain category has an advantage over an upgrade to the same category, i.e.  $M \leftarrow H$  is preferred to  $L \rightarrow M$ , in order to retain higher paying customers at the hotel and avoid having to walk them to another property.

*Rule 4:* An upgrade from a certain category has an advantage over a downgrade from it, i.e.  $M \rightarrow H$  is preferred to  $L \leftarrow M$ .

*Rule 5:* Accommodating customers who have a booking for a certain room category has an advantage to upgrades and downgrades to that category, i.e.  $L \rightarrow L$  is preferred to  $L \leftarrow M$ ,  $M \rightarrow M$  is preferred to  $L \rightarrow M$  and  $M \leftarrow H$ ,  $H \rightarrow H$  is preferred to  $M \rightarrow H$ .

Downgrading from a particular category to the lower one requires that the guest be compensated. Obviously, the customer should be refunded the difference between the price paid for the more expensive room and the rate of the cheaper room in which he is accommodated. The hotel will incur downgrading costs denoted with  $d_H$  and  $d_M$  for the downgraded  $H$  and  $M$  rooms respectively, so that  $d_H > d_M$ . The downgrading costs consist of two elements: *a*) direct financial expenses for compensating the downgraded customer (free dinner, drinks, fruits, vouchers for free spa services up to a limit predetermined by the hotel management), and *b*) brand image losses. Similar to the overbooking costs  $c$ , the financial expenses as an element of downgrading costs are easier to calculate than brand image losses. However, the latter may have detrimental effect on customer satisfaction and loyalty. Considering the facts that in downgrading the hotel does not pay to another hotel for walking guests but accommodates them in a lower category room, provides financial compensation on top of the difference between the two room rates and suffers brand image losses, then

the relationship between the room rates  $r$  and the downgrading costs  $d$  is as follows:  
 $d_H > r_H - r_M$  and  $d_M > r_M - r_L$ .

The optimisation model is:

$$(1) \min (MR_{ob} - MC_{ob})$$

Subject to:

$$(2) (MR_{ob} - MC_{ob}) \geq 0$$

$$(3) MR_i > MC_i$$

$$(4) F(X_i) \in [0; 1], i=H, M \text{ or } L$$

Marginal overbooking costs for a particular room category are the partial derivative of the total overbooking costs  $TC_{ob}$ :

$$(5) MC_H = \frac{\partial TC_{ob}}{\partial X_H} = (-2r_H + 2r_M - c_H - d_H) \cdot F(X_H) + (r_H - 2r_M + 2r_L - c_M - c_L - d_M) \cdot F(X_M) + (-2r_L + c_L + c_M + d_H + d_M) \cdot F(X_H) \cdot F(X_M) + (r_M - r_L - c_L) \cdot F(X_H) \cdot F(X_L) + (r_M - 2r_L + c_L + d_M) \cdot F(X_M) \cdot F(X_L) + (-2r_M + 3r_L - d_M) \cdot F(X_H) \cdot F(X_M) \cdot F(X_L) + r_H$$

$$(6) MC_M = \frac{\partial TC_{ob}}{\partial X_M} = (r_H - r_M - c_H + d_H) \cdot F(X_H) + (-2r_M + 4r_L - 2c_M - 2d_M) \cdot F(X_M) + (r_M - r_L - c_L) \cdot F(X_L) + (-r_H + r_M - 2r_L + c_H + c_M - d_H + d_M) \cdot F(X_H) \cdot F(X_M) + (2r_M - r_L - c_L) \cdot F(X_H) \cdot F(X_L) + (r_M - 2r_L + c_M + c_L + 2d_M) \cdot F(X_M) \cdot F(X_L) + (-3r_M + 3r_L - c_M + c_L - d_M) \cdot F(X_H) \cdot F(X_M) \cdot F(X_L) + r_M$$

$$(7) MC_L = \frac{\partial TC_{ob}}{\partial X_L} = (2r_M - r_L - c_M - c_L + 2d_M) \cdot F(X_M) + (-r_L - c_L) \cdot F(X_L) + (-r_M + c_L - d_M) \cdot F(X_H) \cdot F(X_M) + r_L \cdot F(X_H) \cdot F(X_L) + (-2r_M + c_M + c_L - 2d_M) \cdot F(X_M) \cdot F(X_L) + (r_M - c_L + d_M) \cdot F(X_H) \cdot F(X_M) \cdot F(X_L) + 2r_L$$

Total marginal costs for overbooking are:

$$(8) MC_{ob} = MC_H + MC_M + MC_L = (-r_H + r_M - 2c_H) \cdot F(X_H) + (r_H - 2r_M + 5r_L - 4c_M - 2c_L - d_M) \cdot F(X_M) + (r_M - 2r_L - 2c_L) \cdot F(X_L) + (-r_H - 4r_L + c_H + 2c_M + 2c_L) \cdot F(X_H) \cdot F(X_M) + (3r_M - r_L - 2c_L) \cdot F(X_H) \cdot F(X_L) + (-5r_L + 2c_M + 3c_L + d_M) \cdot F(X_M) \cdot F(X_L) + (-4r_M + 6r_L - c_M - d_M) \cdot F(X_H) \cdot F(X_M) \cdot F(X_L) + r_H + r_M + 2r_L$$

If  $(X_H^0)$ ,  $F(X_M^0)$  and  $F(X_L^0)$  are the solution of (1), then the optimal number of overbooked rooms  $X_H^*$ ,  $X_M^*$  and  $X_L^*$  are the smallest integers for which (9) is fulfilled:

$$(9) \begin{cases} F(X_L^*) \geq F(X_L^0) \\ F(X_M^*) \geq F(X_M^0) \\ F(X_H^*) \geq F(X_H^0) \end{cases}$$

## Chapter 13

### COMBINED HOTEL REVENUE MANAGEMENT TOOLS

Combined hotel revenue management tools include channel management and optimal room-rate allocation (Figure 1.1). We denote them as combined RM tools because they include activities that influence both the price and the quantity of offered services simultaneously.

#### *13.1. Channel management*

As a combined RM tool, channel management has not received its deserved attention in academic literature, in contrast to its profound importance in hotel RM practice. Although the structure of intermediaries used by a hotel and the terms and conditions in contracts with them significantly influence the ADR, RevPAR and the whole RM system of the hotel, only few authors discuss the distribution channels utilised by a hotel from an RM perspective (e.g. Choi & Kimes, 2002; Hadjinicola & Panayi, 1997; Tranter, Stuart-Hill & Parker, 2008). Cross *et al.* (2009), for example, state that after 9/11 hotels looked for wider exposure to guests and were eager to work with third party websites and online merchants against big discounts. However, the huge discounts clients were getting from them, rather than the hotel itself, eroded the relationship between hotels and their guests, and people began to shop third party sites first. Furthermore, Myung, Li & Bai (2009) investigated the impact of e-wholesalers on hotel distribution channels and found that hotels were generally satisfied with the performance and relationships with e-wholesalers despite the conflicts with them. However, Choi & Kimes (2002) concluded that applying RM strategies to distribution channels might not help hotels that are already optimising their revenues by rate and length-of-stay. This might explain the lower interest in channel management as an RM tool compared to the plethora of operations research on overbookings.

In practice, channel management as a combined RM tool includes several activities:



✓ *Choice of distribution channels*

The primary decision to be made in relation to distribution channel management is the choice of distribution channels. A hotel has a great variety of distribution channels from which to choose: direct sales (without the use of intermediaries), GDSs (*Amadeus, Sabre, Travelport* with the brands *Worldspan* and *Galileo*), OTAs (*Booking.com, Venere.com, Expedia.com, Orbitz.com*), and tour operators and travel agents. The more the distributors a hotel works with and the more websites it is presented in, the greater the market visibility of the hotel and the greater the chance that a potential customer will find it and make a booking. Therefore, hotels have incentive to work with many distributors. However, each group of intermediaries has specific **characteristics** which should be considered before signing a contract with them:

- *Global Distribution Systems* serve as electronic platforms connecting accommodation establishments and other intermediaries. A hotel inputs in the GDS the available rooms, prices and booking terms for a particular period, and travel agencies (tour operators/travel agents) or other companies with access to the GDS platform make bookings in the hotel via the GDS platform. The booking is guaranteed either with a corporate credit card or the IATA number of the agency. The customer pays directly to the hotel on the spot. The GDS receives a fee from the hotel for the used bookings, while the travel agency – a commission. The greatest advantage for a hotel to join a GDS is that it does not need to sign separate contracts with thousands of intermediaries – the hotel signs only one contract with the GDS and, through it, it reaches thousands of GDS users. A disadvantage is the high commissions and fees for maintaining the distribution channels, making it suitable for medium to large, and from middle to high category accommodation establishments. It is a very popular distribution channel for hotel chains and all major chains are present in the GDSs.

- *Travel agencies*, depending on their license, can be tour operators or travel agents. *Tour operators* work on a merchant model. They receive net rates from hotels, add their mark-up, and sell to customers (directly or via travel agents), or to other tour operators. The hotel receives the payment for the accommodation from the tour operator, not from the customer. *Travel agents* work on an agency model. They sell to final customers at prices fixed by hotels and, in exchange, receive a commission. A travel agency with both licenses may work with some hotels as a tour

operator and with others as an agent. Travel agencies that work exclusively online via their own websites for hotel reservations are usually referred to as *Online Travel Agencies*. They may operate on both merchant and agency models. Different from GDSs, OTAs target predominantly direct customers and provide great flexibility to hotels regarding changes in prices and allotments. Although commissions received by some OTAs are high (for instance, *Booking.com* charges 15% regular commission and 18% if the hotel is to appear on top of the search results list), the fact that customers pay on the spot directly to the hotel decreases the risk for the hotel – it does not need to wait for payment from the intermediary. OTAs are therefore very suitable for every type of accommodation establishments, regardless of size or category.

Furthermore, GDSs and many OTAs have developed *white labels* – the booking engine of the website of the GDS/OTA is integrated into the website of another travel agency. The user makes a hotel booking on the website of the travel agency and it goes directly to the reservation system of the GDS/OTA. This strategy increases the market coverage of the GDS/OTA providing the white label to its partner travel agencies. This also indirectly benefits the hotel because it even appears on websites of travel agencies with whom it does not have a contract. The direction of payments by the customer depends on the types of contracts between the GDS, the OTA, the hotel and travel agency.

- *Group buying websites* are electronic platforms used for connecting sellers and buyers on which sellers promote highly discounted rates (often above 50% discount) that are valid for limited period of time (e.g. less than 7 days). The original idea of group buying websites was that in order to take advantage of an offer, there must be a minimum number of customers who buy the same product, and guarantee a purchase with their credit cards. However, in recent years, many group buying websites have lifted the requirement for a minimum number of customers and they were transformed into websites for special offers. In the hotel industry, group buying websites (e.g. *Groupon.com*, *Grabo.bg*) connect accommodation establishments with direct customers (not with other distributors). Similar to global distribution systems, a hotel inputs its rates, available rooms and booking terms, but in difference to the GDSs, offers on group buying websites have limited validity in order to stimulate customers to act quickly and make the decision to book rather than postpone and look for offers elsewhere. Group buying websites are useful when a hotel targets

price-sensitive customers. While they attract customers with heavily discounted rates and are financially efficient in the short run, they might have detrimental effect on hotel's image in the long run because the low-priced special offers may create unfavourable customer expectations about the future price of the product – it would be difficult for a hotelier to persuade a customer to pay the full or slightly discounted price for the accommodation when for his previous stay he paid a heavily discounted rate via a group buying website. Therefore, special offers via group buying websites (and special offers in general) should be managed carefully in order to eliminate unjustified customer expectations about the prices. On the other hand, discussing the impact of discounts on destination image Sheridan, Lee & Roehl (2013: 607) stipulate that 'heavily discounted rate deals in a specific destination do not dampen the image of the destination, but rather lead potential visitors to perceive the hotel deal as a great value; consequently, the discount deal positively influences their perceptions about the destination and visit intentions. This can lead to persuading people to come to the city that may have never been before.'

Choice of a distribution channel is influenced by several groups of **factors**:

- *Characteristics of hotel's product* – specialised hotel products (golf, casino, spa & wellness, themed hotel) imply the use of specialised intermediaries (usually tour operators) that have a customer base (the 'right customers') and knowledge to sell such products.

- *Characteristics of the company and its marketing strategy*. Large hotel chains have developed their own reservation systems and customers may book accommodation directly on their websites in hundreds of chain members. The sheer number of properties available on a chain's website makes it competitive and attractive to customers (Ivanov, 2008). Moreover, some of the promotional rates or room availability guarantees are only valid for direct bookings via the chain's website. This makes chains less dependent on intermediaries compared to individual hotels. The marketing objectives also influence the choice of distribution channels. If the aim of a hotel is to achieve very high market visibility, it must be present in many online reservation systems or in several OTAs with large customer bases and/or a white label network.

- *Characteristics of distributors* – size, market coverage, marketing strategy, purchasing/booking criteria. If a seaside hotel wants to attract tourists from Russia, it must make contracts with travel agencies that operate in that market. If a tour

operator is positioned as low-cost, it will not be the 'right' distribution channel for a boutique hotel offering an exclusive product. Furthermore, if a distributor competes on price, it will press the hotel to charge a low price, which is often a source of conflicts between accommodation establishments and intermediaries (see for example Buhalis, 2000; Myung, Li & Bai, 2009) and leads to perceptions of a commoditised product (see Chapter 10).

- *Characteristics of the target market* – type and particular distribution channels target customers prefer to use. If customers prefer to book online then the hotel should be present in various online reservation systems. If they prefer to travel with tour operators, then the hotel should sign contracts with them.

- *Competition* – the revenue manager should consider the distribution channels of competing hotels. They may be used as a benchmark to assess effectiveness and efficiency of hotel's own distribution network. Of course, competitors' contracts with intermediaries are considered a trade secret, but a simple check of online hotel reservation systems regarding the offered hotels at the destination will provide a good idea about the distribution channels used by the competitors. It must be emphasised that it is not necessary for a hotel to use the same distribution channels as competitors. On the contrary, the revenue/marketing manager must concentrate on *the distribution channels that help the hotel reach its target customers*, and these are not necessarily the channels used by its competitors. The latter may provide an idea of what other channels could be used by the hotel (if competitors use channels not applied by the hotel) or, they may identify potential for opportunistic behaviour by the distributor (if a tour operator works with many competing hotels at the destination which it may confront against each other in case of low demand).

Two special issues must be emphasised in relation to choice of a distribution channel:

- It is possible that the increase in the sales of a hotel through one channel is at the expense of sales through another one. This phenomenon is known as *distribution channel cannibalisation* (Ivanov, 2007b). Cannibalisation is inevitable when a hotel uses many channels to reach its target market. It is not a problem if adding one additional channel leads to an increase in total bookings/sales in the hotel – part of the sales are cannibalised (i.e. instead of one channel some customers book at the hotel through another one), but other part of the sales has been generated by customers not previously reached through the existing distribution system of that

hotel. If, however, total sales do not increase, perfect cannibalisation occurs – no new potential customers have been reached by adding the additional distribution channels to the network. Identifying and measuring distribution channel cannibalisation is very difficult and that's why it has been neglected by both academics and practitioners.

- Many leisure hotels at seaside and mountain mass tourism destinations rely on charter tour operators to sell their rooms. Some of them even sign exclusive contracts with single tour operators, leaving themselves entirely at the mercy of those distributors. During negotiations some hoteliers experience what we call the '*large tour operator syndrome*' – they prefer to work with tour operators that bring many tourists to the destination, although this does not necessarily mean that they will bring many tourists to that particular hotel. Tour operators use the number of tourists they bring to the destination as an argument to negotiate for lower prices at hotels. However, they have brought many tourists to the destination because in the previous year they were given low prices by the hotels. This led to their high price competitiveness in tourist generating countries/regions. Therefore, *providing low hotel rates to large tour operators in one year will lead to their increased bargaining power the next year.*

✓ *Determination of prices and booking conditions by distribution channel*

After a hotel has identified the channels it will work with, it must determine the prices and the booking conditions for each. Obviously, not all distribution channels are equal and do not receive the same prices and booking conditions. The prices distributors are given are usually inversely related to the number of overnights they book in the hotel, i.e. the intermediary that sends more guests to the hotel receives lower prices. However, this hotel practice has very flawed logic because *prices must stimulate future bookings, not to serve as a bonus for past sales.* Hotel's pricing decisions determine the distribution channels from which it would actually receive bookings. When a hotel provides low prices to particular intermediaries, it usually receives more bookings from these same distribution channels because they become more price competitive and attract more customers compared to other intermediaries, i.e. we observe a situation of *self-fulfilling prophesy*. Therefore, the revenue manager should be very careful when deciding which channels to stimulate by determining lower prices for them. This decision should be coupled with price parity as discussed in Chapter 11 – the price for the final customers must be nearly the same regardless of

the distribution channel they use. Otherwise, distribution channel cannibalisation will be observed (see above).

**Booking conditions** include:

✓ *Release date* – the number of days before check-in when the distributors (usually the tour operators) must release the unsold rooms from their allotments. Tour operators are interested this release date to be as close to the check-in date as possible to be able to capture any late bookings. To the contrary, hoteliers prefer an earlier release date in order to decrease their risk and have enough time to sell unsold rooms from tour operators' allotments themselves. The intense competition among hotels and extreme bargaining power of intermediaries (especially the tour operators at mass tourist destinations) has led to very short release dates – from 7 days during the main season in holiday destinations to 6 p.m. on the arrival day/check-in date for business hotels. By managing the release date, a hotel may or may not stimulate last-minute bookings through a particular distribution channel.

✓ *Cancellation and amendment terms* – the number of days before check-in until when a customer/distributor can cancel/amend a booking free of charge. The closer the free cancellation deadline to the check-in/stay-over date, the better for the distributor. The cancellation deadline depends on the type of hotel (later for business hotels, earlier for holiday properties), period of the year (earlier during high season, later during off-season), types of customers (earlier for groups, later for individual guests), distributors, etc. It is possible that a hotel applies a uniform cancellation policy regardless of the above criteria. The free cancellation deadline is usually after the release date but it is possible that they may coincide. Figure 13.1 below depicts the relationships between these booking terms dates.

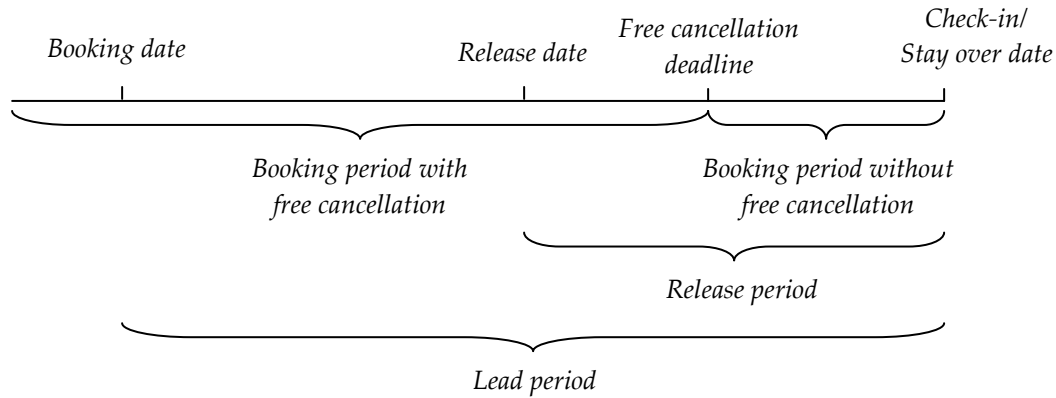

**Figure 13.1.** Relationships between booking term dates

✓ *Payment terms* determine who and when a booking must be paid for to a hotel. A booking payment will be made either by a distributor (OTAs, tour operators, travel agents) or directly by a customer (GDSs, OTAs, travel agents). If a distributor is paying the bill, we can identify different options regarding the timing of the payment:

- Full prepayment – a distributor pays for the booking in advance, before check-in.
- Partial prepayment – a distributor pays part of the booking in advance before check-in (50%, first overnight or other portion determined by the contract with the hotel). The remaining amount is paid after check-out.
- Payment after check-out – a distributor pays for the booking entirely after check-out from the hotel.

Hotels predominantly apply payment after check-out, but at holiday destinations, periods of high demand or for groups, they could request full or partial prepayment.

When a customer is paying directly to the hotel, the booking is usually guaranteed with his credit card (less often by the IATA number of the travel agency or its corporate credit card). On the free cancellation deadline the hotel blocks on the credit card an amount of money equal to the total amount of the booking or at least the first overnight. Payment then takes place at the time of check-in or check-out. The distributor who made the booking receives the commission within a predetermined period after guest check-out – *Booking.com*, for example, issues the invoice for the outstanding commission on the booking made through its website two days after guests' check-out.

✓ *Allotment management by distribution channel*

Allotment management includes the allocation of rooms for sale across different distribution channels. We can identify the following types of contracts between a hotel and intermediaries (see for more details Ivanov, 2008):

– *Commitment* – applied with distributors working on a merchant model. The tour operator prepays for the rooms regardless of whether they are used or not. It is possible that a tour operator pays one price for used/unused rooms or a higher price for used rooms and lower rate for the unused. The hotel cannot sell the rooms blocked for the distributor. The advantage for the hotel is that it receives advance payment regardless of whether the tour operator sells the rooms or not, which could be used for renovations. However, the rates in commitment contracts are the lowest. The advantage for the tour operator is that it is guaranteed the rooms, especially in periods of high demand, but it has to invest a lot of resources to prepay the rooms which limits its financial and operational flexibility. Currently, commitment contracts are rarely used due to the intense competition between accommodation establishments.

– *Allotment* – a contract similar to the commitment, but the tour operator does not prepay for all the rooms, only the rooms used. Unsold rooms allocated to the tour operator have to be released up to the release date. This contract has greater flexibility than the commitment contract for both sides and is widely used. It is often accompanied by an overcontracting strategy by hotels (see Chapter 12). A version of the allotment contract involves the hotel manually making changes in the rooms available for sale in the OTAs working on an agency model.

– *Free sale* – a hotelier gives the intermediary the non-exclusive right to sell free rooms. It is used for both merchant and agency models. A distributor confirms the bookings with its customers/agents at the very moment they are received and must periodically inform the hotel (usually every day) of the confirmed bookings. The bookings are input into hotel's computer reservation system and the revenue/marketing manager informs the distributor of the closed dates immediately (usually on the same day) which the distributor inputs in its own system. The main advantage of the free sale for the hotel is that it can work with many distributors and it can sell the rooms by itself. The advantage for the distributor is that it can show availability of rooms in its system without the need to prepay for any rooms or deal with release periods. However, the free sale has one major disadvantage for both the



hotel and the intermediaries. There is a time gap between the moments the distributor confirms the rooms to its customers/agents, it informs the hotel, these bookings are input in the hotel's computer reservation system, the revenue/marketing manager makes the decision to close a date for sale, the distributor is informed of the closed date, and the date is closed in distributor's reservation system. This whole process can take several hours, especially when the hotel and distributor are located in different time zones. This may create a time window when a customer may make a booking for dates closed for sale and the distributor confirms the booking to that customer without knowing that the dates are actually closed. Applying free sale therefore requires careful planning by the revenue manager. It is recommended that free sale be used only by mid- to large-sized properties (so there are enough rooms in the hotel) and a limitation be set on the maximum number of rooms to be confirmed by a distributor with one booking in order to provide incremental growth of bookings for a particular date.

– *Upon request* – a distributor has not been given any allotment in a hotel, or the rooms from its allotment for a particular date have already been sold out. It sends a booking request to a hotel and the latter confirms or denies it. However, in the modern world, the customers want real-time information about room availability in hotels and instant confirmation of their bookings. In this regard, intermediaries want hotels included in their online reservation systems to show available rooms due to the maxim that '*what is available, that is sellable*'. That's why hoteliers usually work on an upon request basis with smaller intermediaries, e.g. with travel agents.

The type of contract is closely related with the room rate and degree of financial interdependence between the hotel and the distributor. Figure 13.2 below depicts the inverse relationship between the price and the degree of financial interdependence, different for each type of contract. The price is lowest for the commitment contract and highest for the upon request contract, while the financial interdependence between the hotel and the distributor is highest for the commitment contract and is lowest in the upon request one.

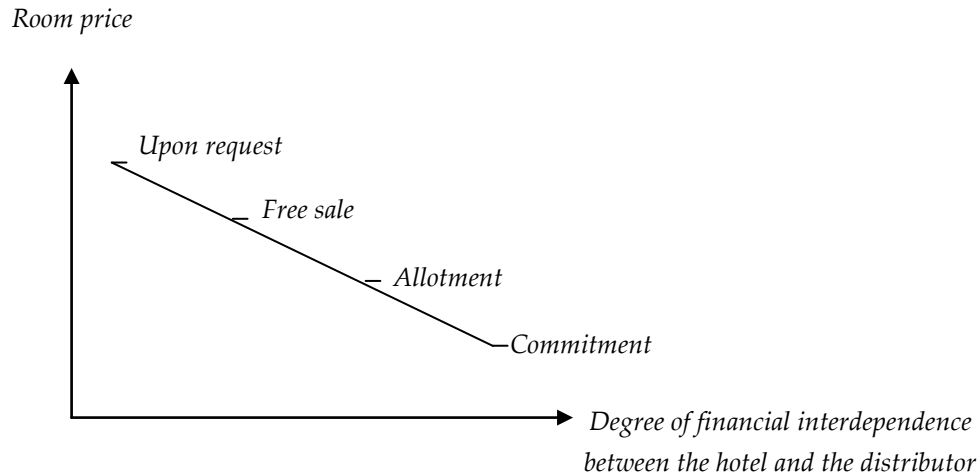

**Figure 13.2.** Relationship between room price and degree of financial interdependence between the hotel and the distributor

✓ *Evaluation of distribution channels*

The final element of channel management is the evaluation of the efficiency of distribution channels. The revenue manager may use the following indicators for channel/distributor evaluation that may be calculated on an annual, quarterly or monthly basis for the hotel as a whole and by room type:

- Sales volume – number of sold rooms and overnights;
- Room revenues from the channel/distributor;
- Total revenues from the channel/distributor – includes revenues from rooms and additional services in the hotel (restaurant, function rooms, casino, spa, golf, etc.)
- Average room rate:

$$(13.1) \text{ Average room rate} = \frac{\text{Room revenues}}{\text{Number of rooms sold}}$$

- Average length of stay:

$$(13.2) \text{ Average length of stay} = \frac{\text{Number of overnights}}{\text{Number of guests}}$$

- Allotment utilisation – sold rooms as percent of total number of rooms in the allotment of the distributor:

$$(13.3) \text{ Allotment utilisation} = \frac{\text{Number of rooms sold}}{\text{Number of rooms in the allotment}} \cdot 100$$

- Channel maintenance expenses – average commission/discount given to a channel/distributor;
- Lead period – the average number of days before check-in when guests make a booking at the hotel with the particular distributor/channel.

Revenue managers may use additional indicators according to the specific characteristics of the accommodation establishment. As information sources for channel evaluation they may use:

- The *property management system* of the hotel that generates various reports containing the above indicators.
- *Distributors' websites* – provide information about the completeness and accuracy of a hotel's description, quality of photographs, up to date prices and promotions, competing hotels. Some distributors provide access to accommodation establishments to their own profiles so hoteliers could easily and timely input current information about their properties.
- *Visit to the office of the distributor* – may generate information regarding the offered competing products, knowledge of current promotions, location of hotel's promotional materials in the office.

The outcome from distribution channel evaluation may include:

- Contract renewal under the same conditions
- Changes in contract prices (increase or decrease)
- Changes in number of rooms in the allotment
- Changes in commissions/discounts
- Change of release periods
- Change of cancellation deadlines
- Termination of the contract with the distributor

### 13.2. Optimal room-rate allocation (room distribution)

The optimal room-rate allocation (e.g. El Gayar *et al.*, 2011; Guadix *et al.*, 2010) refers to the determination of the maximum number of rooms to be booked at different price levels, i.e. the hotel actively limits its available room capacity that may be booked at a given price. Obviously, the number of allocated rooms is inversely

related to price level (i.e. the ‘fare class’) – hotels allocate very few rooms that may be booked at the lowest price in order to attract the attention of customers while they set no limit on the number of rooms bookable at the rack rate. The more rooms that are available at lower fare classes, the higher the sales and occupancy but the lower the ADR. The impact on RevPAR and GOPPAR depends on the relative changes in the occupancy and the ADR. If ADR decreases less than the increase in occupancy, then RevPAR and GOPPAR will increase, and vice versa. On the other hand, if fewer rooms are allocated to lower fare classes, occupancy may drop but ADR will be higher. The impact on RevPAR and GOPPAR will depend on the elasticity of demand. In any case, optimal allocation of number of rooms to fare classes requires the revenue manager to forecast room demand for a particular date at market segment level, and to evaluate the price elasticity of the segments.

Allocation of rooms to different fare classes could be without or with overlapping of the capacities allocated to them which is referred to as *partitioned fare class* or *nesting*, respectively, graphically illustrated in Figure 13.3 below (see also Mauri, 2012: 80).

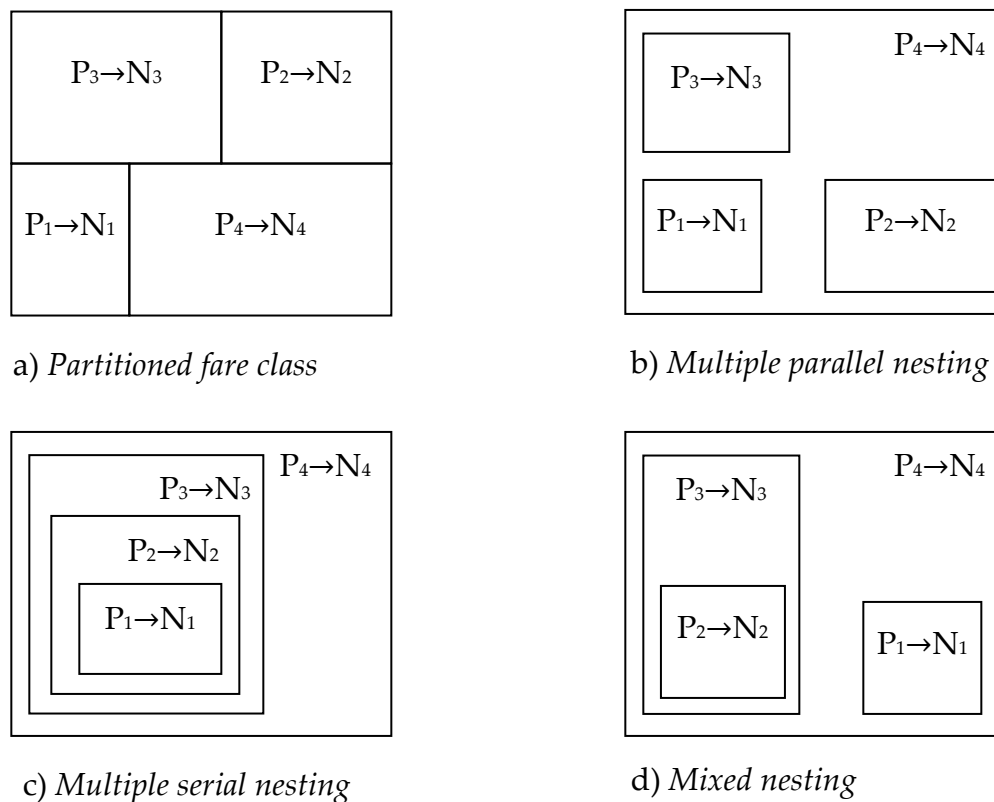

**Figure 13.3.** *Types of room-rate allocation*

Let's assume that the revenue manager of a hotel fixed four price levels  $P_1$ ,  $P_2$ ,  $P_3$  and  $P_4$  so that  $P_1 < P_2 < P_3 < P_4$ . The manager allocates to them the maximum number of rooms that may be booked for each level –  $N_1$ ,  $N_2$ ,  $N_3$  and  $N_4$ . If a particular room capacity  $N_i$  can be sold only at the specific price level  $P_i$  we observe *partitioned fare classes* (Figure 13.3.a). It is simple to apply but contradicts the revenue management's goal to maximise the revenues and the gross operating profit of the hotel – a booking request at a higher price may be declined or confirmed at a lower rate because the number of rooms allocated to that price level have been depleted.

Nesting occurs when for the same room capacity different price levels are applicable. It has three versions. In *multiple parallel nesting* (Figure 13.3.b), room capacities  $N_1$ ,  $N_2$  and  $N_3$  are bookable either at their respective price levels  $P_1$ ,  $P_2$  and  $P_3$  or at the highest price  $P_4$ . It is impossible to book  $N_1$  at rates  $P_2$  or  $P_3$ ,  $N_2$  at rates  $P_1$  and  $P_3$  or  $N_3$  at rates  $P_1$  or  $P_2$ . Furthermore, room capacity remaining after  $N_1$ ,  $N_2$  and  $N_3$  have been sold is only possible to book at rate  $P_4$ . In *multiple serial nesting* (Figure 13.3.c), each room capacity is available at its designated or any higher rate, i.e.  $N_1$  can be booked at rates  $P_1$ ,  $P_2$ ,  $P_3$  or  $P_4$ ,  $N_2$  at  $P_2$ ,  $P_3$  or  $P_4$ ,  $N_3$  at  $P_3$  or  $P_4$ , while the difference between  $N_4$  and  $N_3$  is only bookable at  $P_4$ . *Mixed nesting* (Figure 13.3.d) is a combination of the *parallel* and the *serial nesting*. Nesting as a way for room-rate allocation is better than partitioned fare classes because it allows the room capacity allocated to a particular lower price level to be sold at higher price.

\* \* \*

Pricing, non-pricing and combined revenue management tools are commonly discussed together in research literature. This is a result of the notion that hotel RM is an integrated system that must provide solutions to RM problems for price levels, price fences, booking conditions and overbookings simultaneously through optimal room-rate allocation. Furthermore, the optimal level of overbookings is influenced by room rate (see the model of Netessine & Shumsky (2002) and Ivanov (2006)) which shows the interconnectedness of pricing and non-pricing tools. Finally, hotels try to achieve price parity among and within the different distribution channels they use (Demirciftci *et al.*, 2010; Maier, 2011, 2012) which requires simultaneous application of pricing and non-pricing RM tools (channel management, price discrimination, dynamic pricing, etc.). In practice, pricing, non-pricing and combined RM tools are used simultaneously in order to achieve the RM goals of the hotel.

## Chapter 14

### MANAGING REVENUES IN VARIOUS HOTEL REVENUE MANAGEMENT CENTRES

The *total hotel revenue management* concept discussed in previous chapters is based on the optimisation of the revenues of the hotel from all departments as a whole, not only from its Rooms Division. The revenue manager should think beyond room revenues and consider the total revenues generated by the guest from purchases of additional services. In this regard, this chapter concentrates on revenue management practices in the various hotel departments besides the Rooms Division.

#### *14.1. Revenue management in the F&B department*

Revenue management practices of F&B outlets have received considerable attention in the literature in recent years (Hayes & Miller, 2011; Heo, 2013; Heo, Lee, Mattila & Hu, 2013; Kimes, 1999b; Kimes *et al.*, 1998; Kimes & Robson, 2004; Kimes & Thomson, 2004, 2005; Thomson, 2010; Thomson & Sohn, 2009), but the analysis is predominantly from the perspective of independent outlets needing to optimise only their own revenues and have a high level of independence in revenue management decisions. F&B outlets located in an accommodation establishment have a revenue management strategy subordinate to the RM strategy of the hotel as a whole, especially if the total hotel revenue management concept is fully embraced by the hotel management team.

Usually the F&B department has the greatest potential for revenue generation (besides the Rooms Division) either as provision of regular services (breakfast, lunch, dinner, etc.), banqueting and events (e.g. weddings, conferences, seminars), or catering outside the hotel facility. In the context of accommodation establishments, revenue management in the F&B department is on two levels – 1) the accommodation establishment (property) level and 2) the F&B outlet level. At the *property level*, hoteliers and owners should make several strategic revenue management decisions: number of F&B outlets, types of F&B outlets (breakfast room, restaurant, bar, lobby

bar), room board (RO, BB, HB, FB, AI), type of service (à la carte, buffet), additional F&B services (catering, room service, in-room minibar). The All Inclusive board, for example, limits opportunities for additional revenues from F&B, even if the hotel offers an à la carte restaurant. Room service and minibar extend the capacities of the restaurant and the bar, respectively, providing convenience for the hotel guests and more options for revenue generation.

At the *outlet level*, major restaurant revenue management tools include:

✓ *Capacity management*

The capacity of a restaurant is defined as the number of customers that can be serviced during its working hours. Therefore, restaurant capacity is determined by several factors: physical number of seats, table mix (number of tables with different seating capacity), number of working hours, and average time spent by customers in the restaurant. Table mix (Kimes & Thomson, 2004, 2005) is important because it limits the physical capacity of the restaurant. For example, if a couple is dining at a table for four, the other two seats remain unused as customers usually do not want to sit at the same table with people they do not know. Therefore, the restaurant must conduct an empirical marketing research to determine its prevalent customer group sizes. If results from the research show that half of the guests come in couples, a third in groups of 3-4 guests and the rest customer groups are of 5 or more, then the optimal table mix might be as follows: 50% of the seats on tables for two, 30-35% on the tables for four, and 15-20% on the tables for six. In this way, the structure of seating capacity in the table mix would reflect the structure of group sizes. The maître d'hôtel has the operational responsibility of assigning a table with appropriate seating capacity to each group of customers arriving at the restaurant. Utilisation of seating capacity at a restaurant is positively related to its revenues but, as Heo (2013) indicates, working at high capacity might negatively influence the quality of customers' experience, and may cause stress among employees and operational mistakes.

✓ *Meal duration management*

Meal duration shows how much time customers spend in a restaurant from arrival to departure. The longer the duration, the lower the table turnover and the number of customers served. That's why restaurant managers are keen on decreasing the time spent on serving customers. Part of the meal duration is controllable by the restaurant staff (time needed to accommodate guests at a table, take an order, serve meals,

provide a bill) and proper operations management could make these stages of the customer service process very efficient. However, other stages of the service process are not entirely controllable by restaurant staff – how much time guests would need to consume their food. Limiting customer duration-of-stay in a restaurant might be possible in case of advance bookings only, which are not the norm in F&B outlets located in accommodation establishments. Therefore restaurant managers need to find other ways to control meal duration without leaving customers with an impression that they are being pressed to finish their meals. Kimes *et al.* (1998) identified different measures to decrease the uncertainty of meal duration and improve operational planning in a restaurant: menu design with meals that do not cause customers to linger, better labour scheduling in order to reduce the time to serve guests, pre-bussing of tables, quick check delivery, separate coffee and dessert bar, visual signs, reduced time between customers.

✓ *Menu design and pricing*

From a revenue management perspective, menu design influences the revenues of the F&B outlet in three main ways: meal duration, average check, food expenses of the outlet. Menu items, requiring a lot of time to prepare or consume may cause customers to stay longer in the restaurant without contributing more to revenues because table turnover decreases. Greater choice of menu items requires customers to spend more time before ordering meals but also provides a good opportunity for the waiter to invite customers to order drinks while choosing their meal and offer recommendations about menu items, the daily menu or special offers. The menu structure and its prices will impact the average check (see Chapter 5) – a greater share of expensive items on the menu will increase the average check but might also create the impression that the restaurant is too expensive. Menu items require different costs to prepare which directly impacts total food costs and the gross operating profit of the restaurant.

Menu items are priced differently. Some entries (appetizers, salads, sweets) and beverages have higher mark-ups and contribute significantly to gross operating profit while others (the main course) have deliberately low mark-ups in order to attract customers (see also Davis, Lockwood & Stone, 2006: 112-119). From an RM perspective besides differential mark-ups, a restaurant may add a service, cover or minimum charge (Davis *et al.*, 2006: 113). A service charge is a fixed percent added to a bill which is (supposedly) distributed among employees on duty during that



working day. A cover charge is similar but is a fixed amount for bread, butter or other menu item. A minimum charge is used to dissuade customers who intend to spend only small amount for a cheap menu item or a drink. While contributing to revenues, these types of charges may arouse customer dissatisfaction. If applied, charges must be explicitly and clearly explained with text on the menu.

#### *14.2. Revenue management in a fitness, spa or wellness centre*

Fitness, spa and wellness facilities are often a differentiation factor in the hotel industry. Research in spa revenue management has been marginal (Kimes & Singh, 2009; Modica & Scanu, 2014) and, similarly to restaurant RM, its research has concentrated on independent operators. Similar to RM in the F&B department in hotel, fitness, spa and wellness revenue management should be implemented on two levels: 1) property (hotel) and 2) facility. At the *property level*, strategic revenue management decisions include: whether to offer fitness, spa and wellness facilities at all; what types of fitness, spa and wellness facilities/services to offer [(fitness centre, swimming pool(s), spa, Turkish bath, sauna, massage, jacuzzi, aroma therapy, etc.)]; whether hotel guests are to be charged for the use of fitness, spa or wellness facilities, or they would be included in the room price. These decisions will determine the revenue management potential of the fitness, spa and wellness facilities and services in the accommodation establishment.

At the *facility level*, fitness, spa and wellness revenue management tools include:

##### ✓ *Capacity management*

Capacity of a fitness, spa or wellness facility depends on physical size/number of each (or part of the) facility, working hours, number of employees (for massages), service duration, time interval between customers served. If a massage takes 45 minutes, one masseur works eight hours a day and needs a 15-minute break between massages, and an hour for lunch, he would be able to provide the service to maximum of seven guests per day. If the hotel has two masseurs, the maximum number of available time slots for massages will be 14. The very limited capacity of spa and wellness facilities may cause guest dissatisfaction at all-inclusive resort hotels if the facilities are free of charge but guests cannot use them due to extremely high demand compared to the capacity. Therefore, the capacity of fitness, spa and wellness facilities must be based on the forecasted demand for them by hotel guests and external customers not accommodated in the hotel (e.g. local residents).

✓ *Advance bookings*

Advance bookings decrease the uncertainty of arrivals to fitness, spa and/or wellness facilities and contribute to better operational planning in that department. They may be coupled with prepayment or deposit to guarantee the reservation.

✓ *Service duration management*

Some spa and wellness services have fixed (e.g. massages) while others have more varying service duration (e.g. use of the fitness centre or swimming pool). To provide greater predictability of service duration, spa and wellness treatments are offered in blocks with fixed duration (Kimes & Singh, 2009). Analysis of service operations would help to identify possibilities to decrease the time between customers, and more efficient ways to provide the service.

✓ *Prices*

As a swimming pool and a fitness centre have high fixed costs and very low variable costs, they are usually offered to hotel guests free of charge or at low prices, while external customers (not accommodated at the hotel) must pay regular rates. Other spa and wellness facilities are fee-based due to their high variable costs. The hotelier might use price discrimination and charge different prices for fitness, spa and wellness services during high and low demand periods of the day or week. Lower prices should be framed as discounts from regular prices.

### *14.3. Function rooms revenue management*

Function rooms provide a hotel with an opportunity to attract organisers of various special events (see Table 6.2) and are a major source of revenue for some business and resort hotels. Revenue management research and hotel practice reveals that RM concepts are applicable to managing hotel function rooms as well (Kimes & McGuire, 2001; Orkin, 2003). At the *property level*, the number, size and seating layout in function rooms will determine what type of special events a hotel may host and how many of these events may be hosted simultaneously. Special events like congresses, conventions, balls require very large conference/ball rooms which few hotels can provide. On the other hand, corporate meetings, conferences and seminars require small (up to 50 seats) to medium sized (up to 200 seats) venues and may easily be hosted by hotels. Accommodation establishments without function rooms located near congress centres benefit from the organisation of special events there by providing accommodation to participants in these events.

At the *function room* level revenue management decisions include:

✓ *Capacity management*

While the total area of function rooms is limited, their seating capacity is variable depending on seating layout – banquet, cocktail, boardroom, U-shaped, classroom or theatre style. As seats are usually portable chairs, a function room may be prepared in different seating layout styles, depending on the preferences of the customers. Furthermore, large function rooms may have a foldable (removable) wall in the middle allowing to be transformed into two smaller rooms when necessary. Therefore, although function rooms have limited area, their capacity in terms of the number of people they may accommodate simultaneously in them is flexible.

✓ *Duration management*

Function rooms are rented for different periods of time. However, shorter renting periods (e.g. a room rented for one hour only) might prevent a hotel from selling them to customers who would like to rent function rooms for longer periods. That's why function rooms are normally rented for fixed periods – half day or full day. Per-hour rent may also be possible during periods of low demand.

✓ *Price*

Pricing strategy for the function rooms is subordinate to the general revenue management strategy of the hotel. Services related to function rooms might be priced separately (i.e. rent for the function room, beamer, flipchart, laptop computer) or as one package price. It should be noted that in most cases the use of the function rooms is accompanied by catering and guest rooms bookings, which provides additional revenue opportunities for the hotel. That's why it is also possible that the function room is provided by the hotel free of charge in order to attract the organisers of special events – the lost revenue is offset by the revenues generated by the sale of rooms and catering the event.

#### 14.4. *Casino revenue management*

Research of casino revenue management and operations (Hendler & Hendler, 2004; Kilby, Fox & Lucas, 2005; Kuyumcu, 2002; Norman & Mayer, 1997; Peister, 2007; Zhuang & Li, 2012) is growing as a result of the importance of gambling as a travel motive and its role for revenue generation especially in destinations like Las Vegas and Macao. At the *property level*, strategic casino revenue management decisions relate to: types of games offered in a casino, number and location of tables and slot machines, hours of operation. These decisions influence the revenue potential of the

casino. Casino hotels offer a wide variety of games with highly varying betting levels (from slot machines with a minimum bet of 0.01 USD to roulettes with bets of several hundred USD) in order to attract different market segments.

At the *game/table/slot machine level*, revenue management levers available to casino managers include:

✓ *Capacity management*

For table games, capacity is fixed – it depends on the number of seats available for players around the table. The capacity of slot machines is equal to their number. However, slot machines might be located in different areas of the hotel (in the restaurant, bar, corridors, even in toilets), provided local government regulation allows it, leading to expansion of a casino's physical capacity and more encounter points of the potential players with the slot machines.

✓ *Managing average bets*

Slot machines and table games at casinos allow players to choose their bet within a certain range. A minimum bet protects the financial interests of the casino, while the maximum – of customers. Messages on slot machines show potential wins depending on bet size to stimulate players to increase their bets.

✓ *Managing game pace*

Slow game pace means fewer hands per hour played on a table which lowers a casino's win. It is the role of the croupier to accelerate the pace of a table game. Music, sound and lights serve the same role for slot machines.

✓ *Time management*

The longer players stay in a casino, the larger the amount of money they will gamble. Casinos do not have clocks or windows so players will lose track of time and play longer.

✓ *Managing house advantage*

For some games, like roulette, the house advantage is fixed. For others, like slot machines, the house advantage is flexible. Casinos have to balance the house advantage they set for their slot machines – too low an advantage will attract players but will generate low revenues; too high a house advantage will generate higher revenues from individual players but will dissuade them from playing the slot machines. To balance both objectives (attracting players and generating high revenues) casinos set different house advantages on different slot machines, locate slot machines with a high advantage next to others with low advantage, and regularly change the

advantage of every slot machine in order to avoid pattern recognition of the results by players.

Gambling is an important revenue source for casino hotels and it may well be their major source of revenue. As the gambling revenues depend on the number of players, casino hotels often tend to have large number of guest rooms (above 1000) sold at prices much lower than the prices for non-casino hotels of the same category and similar standard of service. Casino hotel revenue managers attract customers to their hotels with low prices for accommodation who will then spend more for gambling, food and beverages, shopping, entertainment, etc.

#### *14.4. Golf course revenue management*

Golf course revenue management (Barth, 2002; Kimes, 2000; Kimes & Schruben, 2002; Licata & Tiger, 2010; Rasekh & Li, 2011) is based on the same principles as RM in the other hotel departments. Golf revenue management tools include:

##### ✓ *Membership fees*

One of the main sources of revenues for golf clubs and golf hotels are the annual membership fees. Club membership gives a player the right to use a golf course for an unlimited number of rounds during a club's membership period. Members are also entitled to discounts for room accommodation, in F&B outlets, spa centre, etc. To stimulate loyal members, golf resort hotels often provide discounts for early renewals (i.e. before a specific date). If a golf resort hotel includes chalets/houses sold to players but managed by the hotel, discounts are provided to homeowners as well. It is possible that discounts for joint membership in two or more golf resorts of the same chain/owner to be offered (a joint membership programme is offered by *Lighthouse Golf & Spa Resort* and *BlackSeaRama Golf & Villas Resort* in Bulgaria: <http://www.lighthousegolfresort.com/Golf-in-Bulgaria/Membership>).

##### ✓ *Green fees*

Green fees are paid by non-members for the right to use a golf course at specific tee times. Green fees may vary on the basis of:

- Number of holes – usually green fees are set for 9 or 18 holes.
- Time of the day – higher green fees during busy periods of the day and lower fees during periods of low demand.
- Day of the week – lower green fees (discounts) during weekdays.

– Customer characteristics – discounts for guests accommodated in the hotel or owning a chalet/house at the golf resort.

✓ *Fees for additional services*

Golf courses generate revenues for additional services like:

– Golf lessons – prices can vary for a single lesson or a package of several (e.g. 10) lessons, individual or group lessons, lessons for junior players or private playing lessons of 9 or 18 holes.

– Rentals of trolley, golf cart, clubs, golf shoes, etc.

Some or all of the above services may be included in the club membership fee or the green fee.

✓ *Capacity management*

A golf course's capacity depends on its hours of operation and tee time intervals. A golf course open ten hours a day with ten minutes of tee time intervals will have 60 available rounds (600 operational minutes : 10 minutes tee time interval). During high demand periods of the day, the tee time might be decreased to nine or even eight minutes to accommodate more players wishing to use the course.

✓ *Duration management*

The speed with which golfers play influences tee time intervals – a slower play requires longer intervals which decreases the revenue potential of the golf course. Therefore, the management team must know the average play duration of different market segments which would help better plan tee time intervals. Juniors need more time to play a round or certain number of shots than adults and more experienced players and, that's why, the intervals between them must be longer.

✓ *Advance bookings*

Advance bookings help the golf club/hotel better plan the utilisation of the golf course. A hotel may require full or partial prepayment or at least credit card guarantee in exchange for a price discount. Normally club members bookings will have priority over bookings by non-members.

This chapter has revealed that revenue management practices could (and should) be adopted by the various departments in the hotel. It is necessarily that a total hotel revenue management strategy is applied so that the RM decisions taken in each department are in line with the general RM strategy of the hotel.

## Chapter 15

# HOTEL REVENUE MANAGEMENT, ETHICS AND RELATIONSHIP MARKETING

### 15.1. *The role of revenue management in relationship marketing*

With its focus on pricing and inventory management tools, revenue management is closely connected with *customer relationship management* (CRM) (Butscher, Vidal & Dimier, 2009; Iyengar & Suri, 2012; Milla & Shoemaker, 2008; Noone, Kimes & Renaghan, 2003; Wang & Bowie, 2009; Wang, 2012a, 2012b, 2013) as they both aim at maximising revenues although through different means. CRM aims at achieving higher profitability for a company by establishing and sustaining long-lasting and mutually beneficial relationships with its customers. In this sense, CRM has a long-term time horizon while RM is more short-term oriented. Therefore, inevitably CRM and RM may seem as opposing business practices not typically followed by companies simultaneously. Nevertheless, as Noone, Kimes & Renaghan (2003) and Wang (2013) show, CRM and RM should be perceived as *complimentary* business strategies and RM tools can be effectively used in CRM practices. Accommodation establishments, for example, should determine their price levels and booking terms in relation to customer loyalty. As discussed in Chapter 12, the Intercontinental Hotel Group provides room availability guarantee to its Platinum Elite Rewards Club members if certain advance booking conditions have been met. Furthermore, hotel chains provide special rates valid only to their loyalty programme members, thus rewarding them for their patronage. Finally, enrolling guests in loyalty programmes positively influences their spending (Voorhees, McCall & Carroll, 2014) and, therefore, contributes to the improved financial performance of the hotel.

One of the main concepts in CRM is *customer life-time value* (CLTV). In essence, it shows the monetary value of the long-term relationship with a particular customer. In financial terms it can be calculated as the net present value of the gross operating

profit generated by a customer during the whole period of his relationship with the company:

$$(15.1) CLTV_j = \sum_{i=1}^n \frac{GOP_j}{(1+k)^i} \cdot r - AC_j,$$

where:  $CLTV_j$  – lifetime value of customer  $j$ ;  $GOP_j$  – gross operating profit generated by customer  $j$ ;  $AC_j$  – initial customer acquisition costs;  $n$  – duration of the relationship between the customer and the company;  $r$  – retention rate of the customers;  $k$  – discount rate (required rate of return from investments of the company).

The lifetime value is dependent on the customer retention rate  $r$  – the probability that a customer will be retained by the company and will not defect to competitors. Satisfied customers are more likely to repeat their purchases and book again with the same hotel (chain) than those unsatisfied (see Figure 10.2). The lifetime value is also positively influenced by the duration of the relationship between the company and the customer – the longer the relationship, the higher the total gross operating profit generated by the customer. The latter might also increase on a per annum basis as a result of:

- ✓ Increased purchase quantity – e.g. more frequent and/or longer stays in the hotel(s) of the chain);
- ✓ Increased prices of purchased products – e.g. stays in higher standard rooms;
- ✓ Increased purchases of additional services in the hotel;
- ✓ Decreased operating costs to serve hotel guests due to better knowledge about their preferences;
- ✓ Attracted new customers due to positive word-of-mouth generated by current/past customers – e.g. reviews in *Booking.com*, *Tripadvisor.com*, *Foursquare*, comments in *Facebook* and *Twitter*, personal recommendations to friends, relatives, colleagues and acquaintances.

Of course, in order to maintain the relationships with its loyal customers the hotel will provide rooms and/or additional services free of charge or at heavily reduced rates which will decrease the short-term gross operating profit but increase customer satisfaction, retention rate and the lifetime value of the customer. Similar to revenue management, CRM, through the customer lifetime value concept, acknowledges that



different customers have different profitability and importance for the company (see Chapter 1). The hotel (chain) should target only market segments with a positive lifetime value and avoid segments that are too costly to serve.

The above discussion confirms that the concepts of CRM and RM are closely connected. In any case, RM tools play a *supportive* role to CRM in the process of establishing and maintaining long-lasting profitable relationships between the hotel and its customers.

In recent years the concept of customer relationship management has been further developed with the introduction of the concept of *gamification* (Werbach & Hunter, 2012) and *engagement economy* (Palmer, Lunceford & Patton, 2012). According to Werbach & Hunter (2012: 22), external gamification involves existing or prospective customers and is a way to improve relationships between businesses and customers, producing increased engagement, identification with the product, stronger loyalty and, ultimately, higher revenues. In the hotel industry, the concept of gamification is embodied in the collection of points via chain's loyalty programme and the different levels of membership in the programme leading to different customer status and access to different rewards (e.g. free overnights, complimentary services in member hotels of the chain, or exchange for free miles and flight tickets). Additionally, the hotel (chain) might actively use social media for RM purposes (Noone, McGuire & Rohls, 2011), and involve customers through its pages (*Facebook, Foursquare, Twitter, Pinterest, etc.*) and various competitions and quizzes it organises there.

Besides with customers, the hotel (chain) must maintain good relationships with its *distributors* too as elaborated in Chapter 13. In this context the concept of distribution channel cannibalisation, resulting from a hotel's opportunistic behaviour, plays a key role. The prices the hotel charges its direct customers serve as a ceiling for the prices that its distributors may charge their customers. If a hotel charges its direct customers prices that are lower or the same as its distributors' prices, the latter will avoid working with that hotel. This will lead to distribution channel cannibalisation (Chapter 13) and vertical conflicts within the distribution network. Furthermore, relationships with the distributors will be affected by the overbooking practices of the accommodation establishment. When hotels are faced with the necessity to walk guests due to overbooking, they must choose who to walk (Chapter 12). If they walk

a guest sent by a distributor, this decision and the way it is implemented may negatively influence the relationship between the hotel and the distributor.

### *15.2. Ethical issues in hotel revenue management*

Despite their perceived positive impacts on a hotels' bottom line, revenue management techniques have received a huge amount of criticism in terms of grievances and lack of sensible benefits (Bitran & Caldentey, 2003; Koide & Ishii, 2005). This is especially valid for price discrimination and overbooking. Customers feel belied if they discover that they have paid a higher price than other guests for the same room, or if they have to be moved to another hotel. This influences their perception about the *fairness* of revenue management practices in the accommodation establishment (Beldona & Namasivayam, 2006; Beldona & Kwansa, 2008; Choi & Mattila, 2003, 2005, 2006; Heo & Lee, 2011; Hwang & Wen, 2009; Kimes, 2002; Kimes & Wirtz, 2003; Mauri, 2007; Rohlf's & Kimes, 2007; Taylor & Kimes, 2011; Wirtz & Kimes, 2007), their patronage intentions and, ultimately, their future bookings at the same hotel (chain) (see Figure 3.1). Guests might form negative perceptions about the fairness of RM practices as a result of the lack of or incomplete information about prices, rate fences, price dynamics, cancellation, amendment and payment terms, insufficient compensation when being walked, and many other reasons. Kimes (2002: 28-30) pinpoints the RM practices that customers consider acceptable or unacceptable:

#### *Acceptable revenue management practices:*

- ✓ Providing customers with all information regarding prices and booking conditions because hiding information destroys trust.
- ✓ Deep discounts in booking rates in exchange for stricter cancellation / amendment conditions.
- ✓ Different prices for products perceived by customers as different – e.g. weekend and weekday prices.

#### *Unacceptable revenue management practices:*

- ✓ Insignificant discounts in exchange for stricter cancellation/amendment conditions.
- ✓ Changes in booking terms without informing the customer.

Obviously, when information about prices and booking terms is available and understood by guests or when different prices are charged for products perceived by them as different, customers are more inclined to accept revenue management practices. In the other cases, when discounts are insignificant compared to booking amendment/cancellation restrictions or the latter are changed after the booking has been confirmed, customers will be dissatisfied. Furthermore, Choi & Mattila (2005) specify that only informing customers about a hotel's rates is not enough to improve their perceived fairness of revenue management – they have to know the basis for rates variability (i.e. the rate fences) and the booking conditions. Price consistency (integrity), discussed in Chapter 11, contributes positively to guest perceptions of fairness. In any case, the hotel should provide clear, simple, straightforward, understandable information about its prices and promotions because the use of jargon and complicated legal language might create mistrust. Furthermore, hotels should have clear policies and procedures regarding overbookings, walking guests, and compensation. Staff training is essential because their actions on the operational level (who to be walked, what discount/compensation to give) will determine the satisfaction of customers and their feelings and perceptions about the revenue management system of the hotel as a whole.

## Chapter 16

### REVENUE MANAGEMENT PRACTICES OF ACCOMMODATION ESTABLISHMENTS IN BULGARIA

This chapter analyses revenue management practices applied by accommodation establishments in Bulgaria. It first provides a brief overview of the development of Bulgaria's hotel industry in the period 2010-2013. The second section of the chapter elaborates the methodology, section three analyses the results while the last section provides recommendations to accommodation establishment owners, general, marketing and revenue managers for improving applied RM practices.

#### *16.1. Empirical setting*

Bulgarian tourism industry expanded rapidly during the last 15 years and in 2013 it boasted 302433 beds (a 6.6% increase from 2010) as official data from the National Statistics Institute indicate (see Table 16.1). The category of beds is balanced, with roughly one-third of the beds with 1-2, 3 and 4-5 stars, with slight advantage of the highest categories. Regarding the number of accommodation establishments, the situation is a bit controversial. In 2012 the NSI changed its methodology for counting accommodation establishments. In March 2013 the author contacted the NSI for an explanation regarding those changes but their answer was that the NSI did not intend to and would not recalculate the data for the years prior to 2012 according to the new methodology. That's why the statistics calculated on the basis of number of accommodation establishments are not truly comparable over time.

The total number of tourists and number of overnights grew steadily during the analysed period. From a structural perspective, in 2013 4-5 star accommodation establishments accounted for nearly half of the tourists and the overnights. Average revenues from one overnight remained nearly constant for all lodging categories. The average stay was about 3-4 overnights with slightly longer stays at 3- and 4-5 star compared to 1-2 star properties. The average capacity of accommodation

establishments varies greatly – from 54 beds for lower categories to 329 beds for higher categories (in 2013). This was expected, considering the high concentration of 4-5 star hotels on the Black sea coast relying on the economies of scale to stay profitable on the mass 3S tourist market.

**Table 16.1.** *Key statistics of Bulgarian hotel industry*

		2010	2011	2012*	2013*
<i>Number of accommodation establishments</i>	Total	3540	3776	2758	2953
	1-2 stars	2423	2615	1568	1698
	3 stars	823	868	867	904
	4-5 stars	294	293	323	351
<i>Number of beds in accommodation establishments</i>	Total	283641	283251	301140	302433
	1-2 stars	91200	94032	92700	92261
	3 stars	89779	90685	93951	94637
	4-5 stars	102662	98534	114489	115535
<i>Average capacity of the accommodation establishments (in beds)</i>	Total	80,12	75,01	109,19	102,42
	1-2 stars	37,64	35,96	59,12	54,34
	3 stars	109,09	104,48	108,36	104,69
	4-5 stars	349,19	336,29	354,46	329,16
<i>Number of overnights in accommodation establishments</i>	Total	16261170	18855331	20252038	21617474
	1-2 stars	3326381	3753555	4354331	4524469
	3 stars	5135842	6307012	6420223	6671313
	4-5 stars	7798947	8794764	9477484	10421692
<i>Number of tourists spending at least one night in accommodation establishments</i>	Total	4411899	5045332	5494014	5847289
	1-2 stars	1043171	1165774	1364709	1407858
	3 stars	1369715	1597840	1666452	1728036
	4-5 stars	1999013	2281718	2462853	2711395
<i>Revenues of the accommodation establishments from overnights (in BGN)</i>	Total	653736875	733053423	836210287	906305593
	1-2 stars	74148025	86190578	115131158	110696302
	3 stars	176693474	218093171	226198301	238008396
	4-5 stars	402895376	428769674	494880828	557600895
<i>Average revenues of the accommodation establishments from one overnight (in BGN)</i>	Total	40,20	38,88	41,29	41,92
	1-2 stars	22,29	22,96	26,44	24,47
	3 stars	34,40	34,58	35,23	35,68
	4-5 stars	51,66	48,75	52,22	53,50
<i>Average length of stay (number of overnights)</i>	Total	3,69	3,74	3,69	3,70
	1-2 stars	3,19	3,22	3,19	3,21
	3 stars	3,75	3,95	3,85	3,86
	4-5 stars	3,90	3,85	3,85	3,84

Source: NSI (2013b) and author's calculations.

Note: 1 EUR=1.95583 BGN;

\* The data for 2012 and 2013 are according to the new methodology and for 2010 and 2011 – according to the old one.

## 16.2. Methodology

### 16.2.1. Research method 1: Survey of accommodation establishments in Bulgaria

#### *Data collection*

Data collection took place in January-February 2014. Although it was during the winter months, this was not a hindrance for seaside properties to participate in the study, because although they do not serve tourists during that period, their general/marketing/revenue managers work and regularly check their correspondence. An online questionnaire was developed and sent by email to 1991 (67.42%) out of 2953 accommodation establishments operating in Bulgaria in 2013 (NSI, 2013b) whose emails were successfully identified. Two reminders were sent to the potential respondents about two and four weeks after the initial invitation to participate in the study. No more reminders were sent in order to avoid classifying the email as spam and causing negative reactions by potential respondents.

To stimulate the response rate, the author offered an incentive to survey participants (as advised in Illum, Ivanov & Liang, 2010). Every respondent who completed the online questionnaire received a link to a trade press article, co-authored by the researcher discussing sustainable tourism practices in accommodation establishments in Bulgaria. Permission was obtained from the publisher of this closed-access article to use its full text as a reward to survey respondents prior to the distribution of the questionnaire. As a second incentive, the researcher offered an option to survey respondents to participate in a lottery for two complimentary copies of a textbook on hotel marketing co-authored by the researchers. Permission to use this incentive was granted by the textbook publisher. Winners were announced in February 2014. Hoteliers were informed about the winners in order to create trust and stimulate their participation in future research projects. Furthermore, other industry contacts have been fully utilised to stimulate the response rate. The author contacted the Bulgarian Hotel and Restaurant Association, tourist chambers in the two districts with largest number of accommodation establishment in the country (Varna Chamber of Tourism and Bourgas Regional Tourist Chamber), as well as three tour operators working with many hotels in Bulgaria with request for them to distribute the questionnaire to their members/partners. The final sample included 102 accommodation establishments, yielding a 5.12% response rate. This was not surprising as similar small numbers of respondents from the Bulgarian tourism industry were reported by Ivanov, Ivanova & Iankova (2012), Ivanova & Ivanov (2014), Lucas, Marinova & Vodenska (2009).

Sample hotel characteristics are presented in Table 16.2.

**Table 16.2.** *Research method 1: Sample characteristics*

		Number of respondents	Percent
<b>Category</b>	<i>1 star</i>	5	4.9%
	<i>2 stars</i>	25	24.5%
	<i>3 stars</i>	48	47.1%
	<i>4 stars</i>	19	18.6%
	<i>5 stars</i>	5	4.9%
<b>Size</b>	<i>Up to 50 rooms</i>	68	66.7%
	<i>51-100 rooms</i>	17	16.7%
	<i>101-150 rooms</i>	6	5.9%
	<i>Over 150 rooms</i>	11	10.8%
<b>Location</b>	<i>Seaside</i>	34	33.3%
	<i>Mountain</i>	21	20.6%
	<i>Urban</i>	42	41.2%
	<i>Countryside</i>	5	4.9%
<b>Chain affiliation</b>	<i>Chain member</i>	9	8.8%
	<i>Independent</i>	93	91.2%
<b>Total</b>		<b>102</b>	

### *Questionnaire*

The questionnaire included 7 sections. The *first section* collected demographic data about the accommodation establishments – category, size, location, and chain affiliation. The *second section* asked respondents to identify the revenue-generating services in their establishments – rooms, restaurant, bar/lobby bar, minibar, parking, fitness/sauna/spa centre, golf/tennis court and other sport facilities, internet/wi-fi, function rooms, casino. The *third section* concentrated on revenue management tools applied at the hotel – price discrimination, price parity, dynamic pricing, last-minute offers, early bird offers, overcontracting, overbooking, length-of-stay controls, lowest price guarantee, cross selling, upselling, and room availability guarantee. Respondents were asked to evaluate how often they apply specific RM tools (assessed on a 5-point scale from 1-not applied to 5-very often), how important is the application of a tool (from 1-extremely unimportant to 5-extremely important) and what is its impact on the establishment’s revenues (from 1-no impact to 5-very high impact). Responses of establishments which did not apply a particular tool or its impact on sales was not measured were excluded from the analysis of a tool’s impact on sales. Additional questions were asked for each RM tool depending on its specifics. The *fourth, fifth and sixth sections* included questions regarding the revenue management team, RM software and distribution channel management, respectively.

The *last section* was devoted to the revenue management process – RM metrics and forecasting methods. This section also aimed at assessing the level of agreement of respondents (on a 5-point scale from 1-completely disagree to 5-completely agree) with various statements related to the RM process. In general, the questionnaire took about 10-15 minutes to complete.

#### *Data analysis*

The study investigated the impact of category, size, location and chain affiliation on the application of various revenue management practices of accommodation establishments in Bulgaria. The non-parametric Mann-Whitney U-test and Kruskal-Wallis  $\chi^2$  test were adopted to identify the influence of these factors on respondents' answers to the dichotomous questions (applied/not applied). The Kolmogorov-Smirnov z-test revealed that the responses to the 5-point scale questions have a normal distribution. That's why the parametric test ANOVA was used in their analysis (Baggio & Klobas, 2011). Tukey's HSD and Scheffe's post-hoc tests were used for further analysis of the differences identified by ANOVA.

#### *16.2.2. Research method 2: Pricing data about accommodation establishments in Sofia from an OTA*

The aim of this second study was to investigate the impact of different factors on the level of accommodation establishment prices (see also Becerra, Santalo & Silva, 2013; Portolan, 2013). Data were collected regarding rates for 149 accommodation establishments in Sofia in Booking.com for the check-in dates 19<sup>th</sup> February and 22<sup>nd</sup> February 2014 at ten time points during the period December 2013-February 2014 to discover the factors that influence prices. *Booking.com* was chosen as a source of the prices data because this OTA works on the agency model, i.e. the managers of the accommodation establishments determine the prices for the final consumers published on *Booking.com*. That's why the prices and their changes in *Booking.com* reflect the revenue management decisions of hotel management teams and not of the OTA. In this regard, this website was considered as a reliable source of primary data on room prices. In a similar vein, Schütze (2008) used *Hrs.com* for collecting pricing data on hotels in Vienna.

For this study, the capital city of Bulgaria was selected because it has more than 100 accommodation establishments in the chosen OTA from very diverse categories and,



thus, provided more robust results. Because of the time-consuming process of data collection, the study was limited to hotels in Sofia only. Two check-in dates were deliberately chosen because they were outside special event periods in order to investigate the impact of the number of days before check-in on prices. It was assumed that rates during special events would be high but would not change very often, while during slow periods revenue managers are more inclined to use dynamic pricing and change prices weekly, if not daily. Furthermore, one of the dates (19<sup>th</sup> February 2014) was a weekday and the other (22<sup>nd</sup> February 2014) was a weekend day, allowing the author to investigate the factors influencing the prices separately for weekday and weekend dates. Data for each check-in date were collected at the beginning of the study period with a 7-day step which shortened to 3, 2 and ultimately 1 day before check-in in order to capture the effect of last-minute offers. Price data were collected separately for standard double/twin rooms on BB with and without free cancellation. The latter allowed investigation of the impact of cancellation terms on price levels. In addition to prices, data were also collected on various characteristics of the establishments: location, category, *Booking.com* rating, number of guest rooms, number of F&B outlets, presence of a parking facility, swimming pool, air-conditioning, number of function rooms. Table 16.3 provides a summary of the variables with their coding while Table 16.4 presents the characteristics of the accommodation establishments in Sofia used in the research.

**Table 16.3.** *Research method 2: Variables and coding*

Variable	Coding
Price for a double/twin room on BB with free cancellation	In Price
Price for a double/twin room on BB without free cancellation	In Price
Location	1-central, 2-near centre, 3-suburban
Category	1 to 5
<i>Booking.com</i> rating	<i>Booking.com</i> rating from 0.0 to 10.0
Number of guest rooms	Number of guest rooms
Chain affiliation	1-affiliated, 0-independent
Parking	1- available, 0-not available
Air-conditioning	1- available, 0-not available
Swimming pool	1- available, 0-not available
Number of conference rooms	Number of conference rooms
Number of days before check-in	Number of days before check-in

**Table 16.4.** *Research method 2: Sample characteristics*

		Number of respondents	Percent
<b>Category</b>	<i>1 star</i>	34	22.8%
	<i>2 stars</i>	19	12.8%
	<i>3 stars</i>	51	34.2%
	<i>4 stars</i>	35	23.5%
	<i>5 stars</i>	10	6.7%
<b>Size</b>	<i>Up to 50 rooms</i>	108	72.5%
	<i>51-100 rooms</i>	23	15.4%
	<i>101-150 rooms</i>	8	5.4%
	<i>Over 150 rooms</i>	10	6.7%
<b>Location</b>	<i>City centre</i>	71	47.7%
	<i>Near centre</i>	33	22.1%
	<i>Suburban</i>	45	30.2%
<b>Chain affiliation</b>	<i>Chain member</i>	20	13.4%
	<i>Independent</i>	129	86.6%
<b>Total</b>		<b>149</b>	

### 16.3. Discussion of findings

#### 16.3.1. Research method 1: Survey of accommodation establishments in Bulgaria

##### *Revenue management system*

Accommodation establishments were asked to identify their **revenue centres** (see Appendix 16.1). Services that were offered free of charge by the establishments were not considered as revenue centres, because they didn't contribute to hotels' revenues, although they contributed to their competitiveness. Not surprisingly the Rooms Division is the main source of revenues and generates on average 76.86% of establishments' revenues without any significant differences among hotels on the basis of their category, size, location and chain affiliation (Appendix 16.1.b). The analysis, on the other hand, revealed statistically significant differences in the existing revenue centres (Appendix 16.1.a). Not surprisingly, higher category (4-5 stars), larger (above 100 rooms), chain affiliated, seaside and urban properties are more likely to offer and charge for particular services. Results regarding the chain affiliation, however, should be treated with caution. Previous research shows that Bulgarian chain affiliated hotels are mostly large, high category, seaside and urban properties (Ivanova & Ivanov, 2014) – i.e. they have the same profile as the establishments that have more revenue centres. Therefore, we suppose that in this case it is mostly the category, size and location that drive the differences between properties in their revenue centres, and not so much the affiliation to hotel chains. In fact one might argue that large, high category, seaside and urban properties with many revenue centres are more likely to join hotel chains.

**Revenue management metrics** most commonly used by hotel owners/managers in Bulgaria are reported in Table 16.5. Occupancy and average daily rate are most often applied due to their simple calculation, while RevPAR and GOPPAR have been reported to be used by only half of the respondents. Only 6% of the accommodation establishments have reported employing a **revenue manager or a revenue management team** (Table 16.6). In two-thirds of the cases, revenue management is the responsibility of the general manager and in 15% – of the marketing manager. Furthermore, respondents do not think it is likely that they will hire a revenue manager. When asked ‘*If your hotel does not have a revenue manager or revenue management department/team, would you consider hiring a revenue manager?*’ 60.4% of the respondents answered with ‘no’ or ‘definitely no’, while only 10% gave a positive reply. Considering the small average size of accommodation establishments in Bulgaria (Table 16.1), these findings were expected – a separate position of revenue manager is financially feasible only at large properties.

**Table 16.5.** *Revenue management metrics used*

<b>Metric</b>	<b>Number of respondents (N=102)</b>
Occupancy	96
ADR	82
RevPAR	56
GOPPAR	50

**Table 16.6.** *Revenue management responsibility*

<b>RM responsibility</b>	<b>Number of respondents (N=102)</b>
General manager	67
Marketing manager	16
Revenue manager	5
Revenue management team	1
Other manager	1
Owner	5
Not defined as a responsibility of a particular position	8

A great majority of respondents (83.3%) reported that they do not use any specialised **software** for managing the revenues of their accommodation establishments. The rest reported using of general hotel property management software developed by local companies – Clock, Orak, Elit™ Hotel. The use of Opera was mentioned by only two respondents. Nevertheless, respondents acknowledged that specialised RM software (would) help them manage the revenues of the accommodation establishments better,

but they are not willing to spend the money for it (Table 16.7). Chain hotels are willing to pay more for RM software than independent properties and 5-star hotels are willing to pay more than 2- (Tukey's HSD  $p < 0.01$ ) and 3-star establishments ( $p < 0.05$ ). This is natural, considering the larger revenues of higher category properties which make the investment in a specialised software financially feasible.

**Table 16.7.** *Revenue management software*

	Mean	Standard deviation	ANOVA			M-W U test
			Category	Size	Location	Chain affiliation
Do you think a specialised software helps (would help) you manage better the revenues of your accommodation establishment? <sup>1</sup>	3.61	1.036	0.874	0.307	0.371	328.5
How much would you pay annually for specialised RM software? <sup>2</sup>	308.82	486.42	3.603***	2.842**	0.937	231.5**

Notes: \*\*\*Significant at 1% level; \*\* Significant at 5% level; \*Significant at 10% level

<sup>1</sup> measured on a 5-point scale (1-completely disagree; 5-completely agree)

<sup>2</sup> in euros

### *Revenue management tools*

Appendix 16.2.a elaborates on the pricing revenue management tools applied by accommodation establishments in Bulgaria, Appendix 16.2.b – the non-pricing tools, while Appendix 16.3 analyses the distribution channel management. Results reveal that price discrimination and price parity are most often used **pricing RM tools**, while last-minute offers and early bird rates are used less frequently. All pricing tools exhibit above average level of importance (i.e. above 3.00). Contrary to general belief, last-minute offers are perceived as having a lower impact on sales compared to price discrimination, price parity and even early bird rate. This may partially explain the low level importance attributed to group buying websites (like Grabo.bg) for of the accommodation establishments' revenues (see Appendix 16.3.a). Property category influences the use of price parity and the perceptions of its importance and impact on sale. Five-star hotels are more concerned about price parity than 1- (Tukey's HSD  $p < 0.05$ ), 2- ( $p < 0.1$ ) and 3-star properties ( $p < 0.1$ ) and the application of early bird rates is having greater impact on their sales than at the lowest category properties ( $p < 0.1$ ). Mid-sized properties (51-100 rooms) are more likely to pursue price parity (Tukey's HSD  $p < 0.1$ ) and apply early bird rates ( $p < 0.05$ ) than smallest ones (up to 50 rooms). Seaside hotels are much more likely to apply early bird rates than mountain (Tukey's HSD  $p < 0.05$ ), urban ( $p < 0.01$ ), and countryside/rural properties ( $p < 0.05$ ). Chain hotels

are slightly more inclined to use price discrimination and early bird rates than independent hotels, which is expected considering the well-developed revenue management strategies of hotel chains.

Accommodation establishments have indicated the use of various rate fences (Table 16.8). Rate fences related to product characteristics (guest room type, room board, room category), consumption characteristics (length-of-stay, individual/group bookings, period of stay), customer loyalty and booking lead period have greatest adoption and were reported being applied by more than half of the respondents. On the other hand, cancellation and amendment terms, day of the week and room view are less applied. Mostly urban hotels use day of the week as a rate fence, while room view is applied mostly by seaside hotels. Surprisingly, nationality was reported by six respondents, although charging customers different prices on the basis of nationality is forbidden by Bulgarian legislation.

**Table 16.8.** *Rate fences used by accommodation establishments*

<b>Rate fence</b>	<b>Number of respondents (N=102)</b>
Room type (single, double, triple, studio, apartment)	96
Length of stay	90
Individual/group bookings	85
Room board (RO, BB, HB, FB, AI)	80
Customer loyalty	79
Period of stay (seasonality)	66
Lead period	62
Room category (standard, deluxe)	61
Distributor	55
Cancellation and amendment terms	40
Day of the week	29
Room view	18
Nationality	6

Respondents were also asked to report the frequency of changing their prices for a particular date once they were published (Table 16.9). Most of the hotels reported that they keep their prices constant or change them less often than once a month. Only five properties seem to be aggressive and amend their prices at least once a week. Therefore, we may conclude that accommodation establishments in Bulgaria prefer a conservative price strategy and not risk with often price changes.

**Table 16.9.** *Price dynamics: frequency of price changes*

Frequency	Number of respondents (N=102)
Two or more times a week	2
Once a week	3
Once/twice a month	17
Less often than once a month	41
Prices kept constant	39

**Non-pricing revenue management tools** have not received wide acceptance and application by Bulgarian accommodation establishments – only cross-selling and room availability guarantee have average frequency of application (Appendix 16.2.b). Moreover, some non-pricing RM tools have not been recognised as important for the hotel industry – overbookings, length-of-stay controls, lowest price guarantee were reported as having below average (3.00) level of importance. Therefore it seems that hotel owners and managers in the country are very conservative in terms of application of non-pricing RM tools. It may be also that they are not quite familiar with the proper application of these tools which hinders their application.

Category has marginal impact on the application, perceptions of importance and impact on sales of the non-pricing RM tools. Four-star hotels use overbookings more frequently than 1- (Tukey's HSD  $p<0.1$ ), 2- ( $p<0.05$ ) and 3-star ones ( $p<0.1$ ), 1-star properties are least likely to use minimum length of stay compared to higher categories ( $p<0.05$ ), while 3- and 4-star hotels use more often cross-sales ( $p<0.05$ ) than 2-star ones. Unsurprisingly, smallest properties (up to 50 rooms) are least likely to use overcontracting (Tukey's HSD  $p<0.05$ ) and overbooking ( $p<0.05$ ) in comparison to the larger properties (above 100 rooms). Seaside hotels use overcontracting more often than urban hotels (Tukey's HSD  $p<0.01$ ) and are more likely to use overbookings than mountain establishments ( $p<0.05$ ). Chain affiliation impacts positively the use of overbookings, minimum length of stay controls and upselling, which is explained again with the elaborate revenue management strategies of hotel chains.

Online Travel Agencies appear to be the second most important **distribution channel** for accommodation establishments after direct sales (regardless of whether offline or via the website of the hotel/hotel chain). Expansion of OTAs (like *Booking.com*) in Bulgaria, especially during the last five years, with their convenient agency model, explained in Chapter 13, has definitely contributed to the increased importance of

OTAs for the revenues of accommodation establishments in the country. Tour operators and travel agents rank third and fourth in importance, followed by group buying websites, while GDSs are the least important. Evaluation of the various distribution channels seems quite uniform among respondents with few notable exceptions. Tour operators are evaluated as more important by 3- (Tukey's HSD  $p < 0.01$ ) and 4-star ( $p < 0.05$ ) than 2-star hotels, by largest (above 150 rooms) above smallest hotels ( $p < 0.05$ ), by seaside over urban ( $p < 0.01$ ) and countryside ( $p < 0.05$ ) properties. Results are logical, considering that hotels with higher category and larger number of rooms that are located in mass tourism destinations are more attractive to tour operators.

The most widely used types of contracts are those with greatest flexibility for both accommodation establishments and distributors – upon request and free sale, followed by allotment, while commitment has not been widely applied, probably due to its very strict terms for both parties (Appendix 16.3.b). Category influences the frequency of use of various contracts. Three- and four-star hotels are more likely to use allotment than 2-star properties (Tukey's HSD  $p < 0.1$  and  $p < 0.05$ , respectively), 1-star establishments are least likely to use free sale ( $p < 0.01$ ) and upon request contracts ( $p < 0.05$ ) than 3- and 4- star hotels. Logically, the smallest properties less frequently use commitment than large (101-150 rooms) ( $p < 0.1$ ) and the largest (151+ rooms) properties ( $p < 0.01$ ). Counterintuitively, mid-sized (51-100 rooms) reported more often using an upon-request type of contract than the smallest hotels ( $p < 0.05$ ) – one would expect that the smallest properties would not be able to devote rooms to allotments and prefer to work exclusively or predominantly on an upon-request basis. Location-wise, naturally, seaside hotels serving the mass tourism market work more often on commitment contract than urban ones which service mostly unorganised individual tourists (Tukey's HSD  $p < 0.05$ ). Length of the average release period of distributors' allotments stated by the respondents is presented in Table 16.10. It is curious that more than a third of respondents indicated that their average release period is up to one day before check-in. Such short release periods provide too short time window for hotels to sell the unused rooms from distributors' allotments. In this light, overcontracting and overbooking receive greater importance than currently acknowledged by the Bulgarian hotel industry.

**Table 16.10.** *Release period of allotments*

<b>Release period</b>	<b>Number of respondents (N=77)</b>
Same day	9
1 day before check-in	18
2 days before check-in	5
3 days before check-in	8
4-6 days before check-in	18
7 and more days before check-in	19

*Revenue management process*

Past data and personal experience are used most often to **forecast** the RM metrics (Table 16.11). Statistical methods are not widely applied probably due to the specific numerical skills required by managers for their application.

**Table 16.11.** *Forecasting methods used*

<b>Method</b>	<b>Number of respondents (N=90)</b>
Past data	75
Personal experience	64
Statistical methods	22

Appendix 16.4 presents the level of agreement of respondents with various statements some of which related with the revenue management process in the accommodation establishments, their competitive behaviour and perceptions about their customers. Results reveal that hotel owners/managers perceive customers as equally important ( $m=4.39$ ) and try to attract every potential customer ( $m=4.49$ ). However, as discussed numerous times in this book, not all customers are equal and they are not equally important to accommodation establishments. Therefore hotels in Bulgaria fail to recognise their 'right customers'. Moreover, there is a tendency to compete on the basis of price – if competitors decrease prices accommodation establishments would most likely follow suit ( $m=3.25$ ) but would probably not do so if competitors increase their prices ( $m=2.85$ ). The difference in the behaviour in the two situations is statistically significant (paired samples t-test:  $t=4.143$ ,  $p<0.01$ ). Furthermore, when occupancy is low, establishments consider lowering their prices as the best counteraction ( $m=3.82$ ). Few differences between respondents have been identified: seaside properties are more likely to increase their prices following competitor's actions than mountain (Tukey's HSD  $p<0.05$ ) and countryside establishments ( $p<0.05$ ). Logically, considering their predominantly higher category,



chain hotels tend to disagree with the statement that customers prefer lower prices than higher service quality.

In summary, this part of the study of revenue management practices of accommodation establishments in Bulgaria leads us to the following *general conclusions*:

- ✓ Rooms Division is by far the most important source of revenue;
- ✓ Accommodation establishments do not have a revenue manager or an RM team/department and revenue management is usually the responsibility of the general manager;
- ✓ Special RM software is not used, although its importance is acknowledged;
- ✓ Hotels are very conservative in the application of RM tools;
- ✓ Properties prefer distribution channels (direct sales, OTAs) and certain types of contracts with distributors (free sale, upon-request), allowing them greater flexibility and control over pricing and sales.

#### 16.3.2. Research method 2: Pricing data about accommodation establishments in Sofia from an OTA

The impact of accommodation establishments' characteristics and the number of days before check-in on room prices was estimated using the following multiple regression model:

$$(16.1) \ln P_{ij} = \text{const} + \sum_{k=1}^{10} b_k \cdot A_{ik} + b_{11} \cdot D_{ij}$$

where  $\ln P_{ij}$  is the natural logarithm of price of the  $i$ -th accommodation establishment at moment  $j$ ;  $\text{const}$  is the constant;  $A_{ik}$  is the value of  $k$ -th attribute of the  $i$ -th accommodation establishment (namely: location, category, *Booking.com* rating, number of rooms, chain affiliation, number of F&B outlets, parking, swimming pool, air-conditioning, conference rooms);  $D_{ij}$  – the number of days before check-in at moment  $j$ .

Similar to previous studies (Hung, Shang & Wang, 2010; Portolan, 2013) prices were included in the regression model in logarithmic form in order to avoid skewness of results in favour of hotels with high prices. On some survey days, the accommodation establishments were fully booked for any of the two check-in days

under investigation, they did not appear in *Booking.com*, no prices were visualised and they were not bookable. Furthermore, some hotels were offering non-refundable rates during some periods and non-refundable in others. The regression analysis included only those data points for which prices were available. Table 16.12 presents the regression results.

**Table 16.12.** *Factors influencing price – regression model results*

	<b>Check-in date</b>			
	<i>Weekday</i>		<i>Weekend</i>	
	<b>Cancellation terms</b>			
	<i>Non-refundable rate</i>	<i>Free cancellation rate</i>	<i>Non-refundable rate</i>	<i>Free cancellation rate</i>
	<b>Model 1</b>	<b>Model 2</b>	<b>Model 3</b>	<b>Model 4</b>
<i>Dependent variable: ln Price for a double/twin room on BB</i>				
<i>Independent variables standardised coefficients</i>				
Constant (intercept)	(***)	(***)	(***)	(***)
Location	-0.015	-0.108***	-0.089***	-0.139***
Category	0.288***	0.394***	0.774***	0.716***
<i>Booking.com</i> rating	0.024***	0.016	0.157***	0.177***
Number of rooms	0.047***	-0.007	0.004	0.044
Chain affiliation	-0.009	-0.012	0.067***	0.082***
Number of F&B outlets	0.065***	0.076*	0.079***	0.026
Parking	-0.009	0.032	-0.062***	0.086***
Swimming pool	-0.055***	0.014	-0.058***	-0.034*
Air-conditioning	0.041***	0.056	0.039**	-0.006
Conference rooms	-0.069***	0.051	-0.019	-0.019
Number of days before check-in	0.706***	0.098	-0.006	0.016
<i>Model summary characteristics</i>				
R	0.979	0.611	0.898	0.879
R <sup>2</sup>	0.958	0.374	0.806	0.772
Adjusted R <sup>2</sup>	0.958	0.364	0.803	0.770
Number of valid observations	722	1031	740	1039

Note: \*\*\*Significant at 1% level; \*\* Significant at 5% level; \*Significant at 10% level

Regression analysis was based on four models with the same explanatory independent variables but different dependent variables:

- Model 1: *ln* Price for a double/twin room on BB on 19<sup>th</sup> February 2014, non-refundable rate;
- Model 2: *ln* Price for a double/twin room on BB on 19<sup>th</sup> February 2014 with free cancellation;

- Model 3: *ln* Price for a double/twin room on BB on 22<sup>nd</sup> February 2014, non-refundable rate;
- Model 4: *ln* Price for a double/twin room on BB on 22<sup>nd</sup> February 2014 with free cancellation.

Results indicate that distance from city centre depresses the prices in all 4 models (cf. Lee & Jang, 2012), while category, number of F&B outlets and air-conditioning has generally positive impact. Surprisingly, the presence of a swimming pool is mostly negatively related with the price. From a customer relationship management perspective (Chapter 15) it is important to indicate that the *Booking.com* rating of the accommodation establishment has a positive influence on its prices in all four models and in three of them the respective standardised regression coefficient is statistically significant at the 1% level. This is a proof that hard work pays off: when hotels provide superior value (Chapter 10), customers reward them with positive reviews which increase the competitiveness of the establishments, attract/divert demand to them and they could afford to charge higher prices. The other explanatory variables do not have consistent impact on prices. Chain hotels have higher prices during the weekend date (Models 3 and 4) but slightly lower during the weekday date (Models 1 and 2). The number of days before check-in has highly positive and statistically significant at the 1% level impact on prices only in Model 1 (weekday, non-refundable rate), i.e. the larger the number of days before check-in, the higher the price, and vice versa – prices are lower closer to the check-in date. Therefore, regarding the non-refundable weekday rates accommodation establishments used last minute offers. The regression coefficients for the number of days before check-in in the other three models are not significant. In general the four models have high explanatory power: Model 1 explains 95.8% of the variations in the dependent variable, Model 3 – 80.3%, Model 4 – 77%, while Model 2 – 36.4%.

**Table 16.13.** *Differences between refundable and non-refundable rates*

	Check-in date			
	Weekday		Weekend	
	Mean	Standard deviation	Mean	Standard deviation
Absolute difference in BGN	19.68	17.84	16.76	19.14
Difference in percent	14.31	11.70	19.14	14.43

In addition, differences between the refundable and the non-refundable rates were investigated for both check-in dates (Table 16.13). The mean difference was 19.68 BGN for the weekday and 16.76 BGN for weekend check-in date. Considering the fact that the absolute value of the difference is skewed in favour of high priced properties, Table 16.13 also presents the average discount given to non-refundable rates as a percentage of free cancellation rates. Findings indicate that for the weekend check-in date the discount for non-refundable rates from the free cancellation rates was higher (19.14%) than for the weekday check-in date (14.31%). It should be emphasised that, in light of the 3D pricing model elaborated in Chapter 11, room rates for hotels in Sofia are not entirely consistent. In 32 cases, representing 11 hotels, the non-refundable rate for the weekday check-in date was higher than the free cancellation rate, although it should be the opposite. For the weekend check-in date in 45 cases (12 hotels) the situation was the same. Moreover, for ten hotels the non-refundable rate was higher than the free cancellation rate for both check-in dates, which contradicts the revenue management logic elaborated throughout this book. Further research is needed to investigate the reasons why some Bulgarian hoteliers charge higher non-refundable rates than refundable rates.

**Table 16.14.** *Average percentage difference between the current price for the particular check-in date and the price on the base date*

Check-in date					
Weekday			Weekend		
Days before check-in	Non-refundable rate	Free cancellation rate	Days before check-in	Non-refundable rate	Free cancellation rate
45	0.73%	-0.24%	48	0.39%	-0.23%
38	1.40%	-0.36%	41	0.66%	-0.64%
31	0.98%	-0.40%	34	-0.19%	-1.13%
24	-0.69%	-1.44%	27	-1.21%	-1.37%
17	-0.46%	-0.98%	20	-0.62%	-1.07%
9	-0.61%	-1.77%	12	-0.59%	-2.73%
3	-2.68%	-1.43%	3	-2.50%	-2.39%
2	-3.21%	-0.69%	2	-2.94%	-2.91%
1	-3.59%	-5.48%	1	-2.34%	-2.42%

*Notes:* Base date is 28<sup>th</sup> December 2013; Average percentage differences calculated only for hotels bookable for the particular check-in date the respective number of days before check-in.

We further investigated the dynamics of prices for the two check-in dates (see Table 16.14). Findings clearly indicate that accommodation establishments in Sofia that were not fully booked for the two check-in dates tended to lower their prices closer to

the check-in date, thus providing additional confirmation about the application of last-minute offers by accommodation establishments in Sofia in light of the regression analysis results (Table 16.12).

In summary, the second part of the study of revenue management practices of accommodation establishments in Sofia justifies the following *general conclusions*:

- ✓ Location, category, number of F&B outlets and air-conditioning have a strong impact on prices;
- ✓ *Booking.com* rating positively influences prices;
- ✓ Accommodation establishments tend to give last-minute offers;
- ✓ Some accommodation establishments are not consistent in their tariff conditions and charge non-refundable rates higher than their free cancellation rates.

#### 16.4. Recommendations

The analysis of revenue management practices of accommodation establishments in Bulgaria revealed that there is vast ground for industry improvement. Table 16.15 provides some practical recommendations that might help owners and managers in their pursuit of higher revenues.

**Table 16.15.** *Recommendations for improvement of the RM practices of accommodation establishments in Bulgaria*

Direction	Practical action
<i>Revenue centres</i>	<ul style="list-style-type: none"> <li>✓ Diversification of revenue centres</li> <li>✓ Development of an RM strategy for each revenue centre</li> <li>✓ Measurement of revenue centres' contribution to the revenues and profit of the property</li> </ul>
<i>Customers</i>	<ul style="list-style-type: none"> <li>✓ Identification and profiling of the 'right' customer for the accommodation establishment</li> <li>✓ Evaluation of life-time value of the customers</li> </ul>
<i>Value</i>	<ul style="list-style-type: none"> <li>✓ Development of a clear value proposition for the hotel</li> <li>✓ Proper communication of the value proposition to the 'right' customers ('The promise')</li> <li>✓ Prompt delivery of the value proposition ('Keep your promise')</li> </ul>
<i>RM metrics</i>	<ul style="list-style-type: none"> <li>✓ Calculation of more RM metrics in order to get a better picture of the revenue potential of the establishment</li> <li>✓ Calculation of RM metrics for each revenue centre</li> </ul>
<i>RM software</i>	<ul style="list-style-type: none"> <li>✓ Use hotel property management software if specialised RM software is not financially affordable</li> </ul>

<b>Direction</b>	<b>Practical action</b>
<i>RM team</i>	<ul style="list-style-type: none"> <li>✓ Train the general manager, the marketing manager, the front office manager in the principles and practices of hotel revenue management</li> <li>✓ Stimulate all employees to use RM tools when relevant (e.g. upselling, cross-selling)</li> </ul>
<i>RM tools</i>	<ul style="list-style-type: none"> <li>✓ Be more aggressive in the application of the pricing and non-pricing RM tools, especially in terms of price discrimination and overbookings</li> <li>✓ Be more consistent in the booking terms and the price level in regard to refundable/non-refundable rates – the application of the 3D pricing model would be beneficial</li> </ul>
<i>RM process</i>	<ul style="list-style-type: none"> <li>✓ Use booking curves, time series, regression analysis in forecasting</li> <li>✓ Measurement of the impact of RM practices on property's revenues</li> </ul>

## Appendix 16.1. Revenue management centres of accommodation establishments in Bulgaria

### a) Revenue centres

Revenue centre	Yes	No	Kruskal-Wallis $\chi^2$ test			M-W U test
			Category	Size	Location	Chain affiliation
Restaurant	74	28	24.133***	15.539***	2.940	343.5
Bar/lobby bar	60	42	23.923***	19.960***	9.045**	280.5*
Minibar	51	51	28.080***	9.932**	27.088***	240**
Parking	24	78	14.635***	13.398***	13.750***	169.5***
Fitness/spa/wellness	29	73	27.927***	24.473***	6.700*	243***
Golf/tennis/other sports	3	99	0.875	2.643	0.437	381
Internet/Wi-fi	22	80	9.544**	18.009***	20.061***	262.5***
Function rooms	47	55	17.769***	15.288***	17.493***	222***
Rentals	24	78	10.812**	25.005***	8.824**	322.5

Note: \*\*\*Significant at 1% level; \*\* Significant at 5% level; \*Significant at 10% level

### b) Percentage of revenues from Rooms Division

	ANOVA			M-W U test		
	Mean	Standard deviation	Category	Size	Location	Chain affiliation
Percentage of revenues coming from Rooms Division	76.86	18.76	0.698	0.079	1.577	383

Note: \*\*\*Significant at 1% level; \*\* Significant at 5% level; \*Significant at 10% level

## Appendix 16.2. Revenue management tools of accommodation establishments in Bulgaria

### a) Pricing revenue management tools

	N	Mean	Standard deviation	ANOVA			M-W U test
				Category	Size	Location	Chain affiliation
<b>Price discrimination</b>							
Frequency of application	102	3.14	1.282	1.559	0.923	1.423	266.5*
Importance for the industry	102	3.74	1.185	0.754	0.343	1.507	324.5
Impact on property sales	65	3.40	0.981	1.511	0.642	0.804	135.5
<b>Price parity</b>							
Degree of application	102	3.59	1.285	3.961***	2.927**	1.688	369
Importance for the industry	102	3.82	1.164	3.833***	2.625*	0.793	342
Impact on property sales	59	3.58	0.894	2.545**	1.272	0.421	135
<b>Last minute offers</b>							
Frequency of application	102	2.31	1.258	0.537	0.485	2.488*	397
Importance for the industry	102	3.39	0.977	0.813	0.036	1.581	411
Impact on property sales	57	2.77	0.982	2.386*	0.172	0.133	105.5
<b>Early bird rates</b>							
Frequency of application	102	2.76	1.484	2.755**	4.689***	10.514***	256.5**
Importance for the industry	102	3.53	0.982	1.684	2.436*	5.745***	316.5
Impact on property sales	67	3.16	1.163	2.358*	1.553	6.433***	260.5

Note: \*\*\*Significant at 1% level; \*\* Significant at 5% level; \*Significant at 10% level



## Appendix 16.2. Revenue management tools of accommodation establishments in Bulgaria

### b) Non-pricing revenue management tools

	N	Mean	Standard deviation	ANOVA			M-W U test
				Category	Size	Location	Chain affiliation
<b>Overcontracting</b>							
Frequency of application	102	2.06	1.341	1.929	6.703***	5.886***	329
Importance for the industry	102	3.15	1.189	1.125	2.789**	4.167***	341
Impact on property sales	55	3.02	1.163	1.580	1.634	9.258***	96.5
Percent of overcontracting	50	36.00	36.715	0.579	0.667	2.484*	87
<b>Overbooking</b>							
Frequency of application	102	1.46	0.779	3.318**	14.184***	2.942**	182***
Importance for the industry	102	2.28	1.205	0.343	3.689**	1.584	245.5**
Impact on property sales	33	2.52	1.121	0.178	1.771	0.231	50.5*
Percent of overbooking	33	5.27	3.769	1.235	2.843*	0.565	73
<b>Length-of-stay controls</b>							
<i>Minimum length-of-stay control</i>							
Frequency of application	102	1.97	1.181	3.016**	1.880	7.103***	247**
Importance for the industry	102	2.66	1.286	1.192	2.010	2.315*	265*
<i>Maximum length-of-stay control</i>							
Frequency of application	102	1.51	0.972	1.713	3.226**	0.299	409.5
Importance for the industry	102	1.99	1.165	0.698	0.667	0.503	351.5
<i>Length-of-stay controls</i>							
Impact on property sales	45	3.02	1.138	0.688	0.307	0.916	91.5
<b>Lowest price guarantee</b>							
Frequency of application	102	1.96	1.319	1.810	0.689	0.118	320
Importance for the industry	102	2.86	1.211	0.668	0.614	0.535	304.5
Impact on property sales	39	3.15	1.136	0.981	0.391	1.108	45**
<b>Cross-selling</b>							
Frequency of application	102	2.98	1.659	3.048**	2.054	1.162	330
Importance for the industry	102	3.84	1.264	1.377	0.515	0.148	374.5
Impact on property sales	66	3.45	1.192	0.152	0.387	0.927	231
<b>Upselling</b>							
Frequency of application	102	2.23	1.210	2.358	0.881	2.160*	204.5***
Importance for the industry	102	3.15	1.172	1.212	0.360	0.641	237**
Impact on property sales	55	2.75	1.109	3.097	1.270	0.555	154.5
<b>Room availability guarantee</b>							
Frequency of application	102	2.99	1.686	2.633**	0.981	1.317	323.5
Importance for the industry	102	3.89	1.226	2.063*	0.600	0.346	396
Impact on property sales	59	3.64	1.310	0.333	0.222	1.667	184.5

Note: \*\*\*Significant at 1% level; \*\* Significant at 5% level; \*Significant at 10% level

### Appendix 16.3. Distribution channel management

#### a) Level of importance of the various distribution channels

			ANOVA			M-W U test
	Mean	Standard deviation	Category	Size	Location	Chain affiliation
GDSs	2.18	1.531	1.524	1.247	1.203	374
OTAs	3.90	1.206	2.273*	0.736	2.808**	346
Tour operators	3.72	1.396	4.604***	5.494***	5.080***	330.5
Travel agents	3.53	1.333	1.883	3.293	0.740	343.5
Group buying websites	2.41	1.472	1.847	1.051	3.076**	390.5
Direct sales via the website	4.14	1.169	0.881	0.642	1.842	408
Other direct sales (email, phone)	4.43	0.873	1.908	4.088***	1.247	400

Note: \*\*\*Significant at 1% level; \*\* Significant at 5% level; \*Significant at 10% level

#### b) Frequency of application of the different types of contracts with distributors

			ANOVA			M-W U test
	Mean	Standard deviation	Category	Size	Location	Chain affiliation
Commitment	1.58	1.085	1.297	5.303***	3.934**	283**
Allotment	3.58	1.531	3.814***	3.368**	0.587	390
Free sale	3.94	1.370	4.022***	2.152*	0.234	393
Upon-request	4.13	1.287	3.138**	3.033**	0.724	371.5

Note: \*\*\*Significant at 1% level; \*\* Significant at 5% level; \*Significant at 10% level

### Appendix 16.4. Level of agreement with various statements

			ANOVA			M-W U test
	Mean	Standard deviation	Category	Size	Location	Chain affiliation
If occupancy is low it is best to lower the prices	3.82	1.094	1.602	0.231	3.017**	292.5
Each customer is equally important for the hotel	4.39	0.966	1.869	1.371	0.247	398
We try to attract every potential customer	4.49	0.793	1.669	1.240	0.125	402
If competitor decrease prices we decrease our prices too	3.25	1.094	2.162*	0.220	1.695	324.5
If competitor increase prices we increase our prices too	2.85	1.057	0.795	0.298	4.210***	383.5
Customers prefer lower prices than higher quality	3.35	1.131	1.026	1.853	0.102	183***
Maintaining good relations with the distributors is important for property's revenues	4.30	0.920	0.756	2.965**	0.888	288.5*
Selling additional services is important for property's revenues	4.07	0.847	0.435	0.894	2.430*	410.5
When we set the prices and booking terms we consider customers' perception of these	4.06	0.842	0.420	1.003	0.212	340.5
In general the application of the RM tools contributes positively to the revenues of our property	4.01	0.850	0.779	0.938	1.471	321

Note: \*\*\*Significant at 1% level; \*\* Significant at 5% level; \*Significant at 10% level

## CONCLUDING THOUGHTS

In the last 30 years hotel revenue management has gained the status of mainstream research area. It is constantly developing, driven largely by the evolving nature of revenue management practices applied by accommodation establishments. I hope that the integrative framework of hotel revenue management elaborated in this monograph will contribute to further advancements in the field and be useful for all readers – students, researchers, revenue/marketing/front office/general managers of accommodation establishments. Like every book, this monograph presents the viewpoint and experience of its author. I would be glad if you share with me by email to *stanislav.ivanov@vumk.eu* or *stanislav\_h\_ivanov@yahoo.com* or on the Facebook page <https://www.facebook.com/RevenueYield> your valuable feedback, comments, experiences, cases, recommendations, research papers.

The Author

## REFERENCES

- Abrate, G., Fraquelli, G. & Viglia, G. (2012). Dynamic pricing strategies: Evidence from European hotels. *International Journal of Hospitality Management*, 31(1), 160-168.
- Anderson, C. K., & Xie, X. (2010). Improving hospitality industry sales: Twenty-five years of revenue management. *Cornell Hospitality Quarterly*, 51(1), 53-67.
- Anderson, C. K., & Xie, X. (2012). A choice-based dynamic programming approach for setting opaque prices. *Production and Operations Management*, 21(3), 590-605.
- Andersson, T. D. (2007). The tourist in the experience economy. *Scandinavian Journal of Hospitality and Tourism* 7(1), 46-58.
- Aslani, S., Modarres, M & Sibdari, S. (2013). A decomposition approach in network revenue management: Special case of hotel. *Journal of Revenue and Pricing Management*, 12(5), 451-463.
- Avinal, E. A. (2006). Revenue management in hotels. *Journal of Foodservice Business Research*, 7(4), 51-57.
- Aziz, H. A., Saleh, M., Rasmy, M. H. & Elshishiny, H. (2011). Dynamic room pricing model for hotel revenue management systems. *Egyptian Informatics Journal*, 12(3), 177-183.
- Badinelli, R. D. (2000). An optimal, dynamic policy for hotel yield management. *European Journal of Operations Research*, 121(3), 476-503.
- Baggio, R., & Klobas, J. (2011). *Quantitative methods in tourism. A handbook*. Bristol: Channel View Publications.
- Baker, S., Bradley, P. & Huyton, J. (1994). *Principles of hotel front office operations*. New York: Cassell.
- Baker, T. (2014). *London hoteliers worry over commoditization*. HotelNewsNow.com, 21<sup>st</sup> January. Available online at: <http://www.hotelnewsnow.com/article/12986/London-hoteliers-worry-over-commoditization> (Accessed on 23.01.2014)
- Baker, T. K. & Collier, D. A. (1999). A comparative revenue analysis of hotel yield management heuristics. *Decision Sciences*, 30(1), 239-263
- Baker, T. K. & Collier, D. A. (2003). The benefits of optimizing prices to manage demand in hotel revenue management systems. *Production and Operations Management*, 12(4), 502-518.
- Baker, T. K. & Collier, D. A. (2005). The economic payout model for service guarantees. *Decision Sciences*, 36(2), 197-220.
- Baker, T., Murthy, N. N. & Jayaraman, V. (2002). Service package switching in hotel revenue management systems. *Decision Sciences*, 33(1), 109-132.
- Barth, Y. (2002). Yield management: opportunities for private club managers. *International Journal of Contemporary Hospitality Management*, 14(3), 136-141.
- Bayoumi, A. E.-M., Saleh, M., Atiya, A. & Aziz, H. A. (2013). Dynamic pricing for hotel revenue management using price multipliers. *Journal of Revenue and Pricing Management*, 12(3), 271-285.

- Becerra, M., Santalo, J. & Silva, R. (2013). Being better vs. being different: Differentiation, competition, and pricing strategies in the Spanish hotel industry. *Tourism Management*, 34, 71-79.
- Beck, J., Knutson, B., Cha, J. & Kim, S. (2011). Developing revenue managers for the lodging industry. *Journal of Human Resources in Hospitality & Tourism*, 10(2), 182-194.
- Beldona, S. & Kwansa, F. (2008). The impact of cultural orientation on perceived fairness over demand-based pricing. *International Journal of Hospitality Management*, 27(4), 594-603.
- Beldona, S. & Namasivayam, K. (2006). Gender and demand-based pricing: Difference in perceived (un)fairness and patronage intentions. *Journal of Hospitality & Leisure Marketing*, 14(4), 89-107.
- von Bertalanffy, L. (1969). *General system theory: Foundations, development, applications*. New York: George Braziller.
- Bertsimas, D. & Shioda, R. (2003). Restaurant revenue management. *Operations Research*, 51(3), 472-486.
- Bitran, G. & Caldentey, R. (2003). An overview of pricing models for revenue management. *Manufacturing & Service Operations Management*, 5(3), 203-229.
- Bitran, G. & Gilbert, S. M. (1996). Managing hotel reservations with uncertain arrivals. *Operations Research*, 44(1), 35-49.
- Bitran, G. & Mondschein, S. V. (1995). An application of yield management to the hotel industry considering multiple day stays. *Operations Research*, 43(3), 427-443.
- Bodea, T., Ferguson, M & Garrow, L. (2009). Choice-based revenue management: data from a major hotel chain. *Manufacturing & Service Operations Management*, 11(2), 356-361.
- Bowdin, G. A. J., Allen, J., O'Tole, W., Harris, R. & MacDonnell, I. (2006). *Event management*. 2nd ed., Oxford: Butterworth-Heinemann.
- Bowie, D. & Buttle, F. (2011). *Hospitality marketing*. 2<sup>nd</sup> ed. Oxford: Butterworth-Heinemann.
- Bowman, C. (1991). *Charting competitive strategy*. Cranfield CERES, School of Management Working and Occasional Paper No. SWP33/91. Available at: <https://dspace.lib.cranfield.ac.uk/bitstream/1826/344/2/SWP3391.pdf> (Accessed on 27.07.2008)
- Brannas, K., Hellstrom, J. & Nordstrom, A. (2002). A new approach to modeling and forecasting monthly guest nights in hotels. *International Journal of Forecasting*, 18(1), 19-30.
- Breidert, C. (2006). *Estimation of willingness-to-pay: Theory, measurement, application*. Wiesbaden: GWV Fachverlage.
- Buckhiester, B. (2012). *Optimizing total revenue management*. Hotelnewsnow.com, 23<sup>rd</sup> May. Available online at: <http://www.hotelnewsnow.com/Article/8251/Optimizing-total-revenue-management> (Accessed on 05.01.2014).
- Buhalis, D. (2000). Relationships in the distribution channel of tourism: conflicts between hoteliers and tour operators in the Mediterranean region. *International Journal of Hospitality and Tourism Administration*, 1(1), 113-139.
- Burger, C.J.S.C, M. Dohnal, M. Kathrada, R. Law (2001). A practitioners guide to time-series methods for tourism demand forecasting – a case study of Durban, South Africa. *Tourism Management*, 22(4), pp. 403-409.
- Burgess, C. & Bryant, K. (2001). Revenue management - the contribution of the finance function to profitability. *International Journal of Contemporary Hospitality Management* 13(3), 144-150.
- Butscher, S. A., Vidal, D. & Dimier, C. (2009). Managing hotels in the downturn: Smart revenue growth through pricing optimisation. *Journal of Revenue and Pricing Management*, 8(5), 405-409.

- Carroll, B. (2011). Demand management. In Sturman, M. C., Corgel, J. B. & Verma, R. (Eds.) *The Cornell School of Hotel Administration on Hospitality: Cutting edge thinking and practice*. Hoboken, NJ: John Wiley & Sons, pp. 174-191.
- Carvell, S. A. & Quan, D. A. (2008). Exotic reservations – Low price guarantee. *International Journal of Hospitality Management* 27(2), 162-169.
- Chen, C. & Kachani, S. (2007). Forecasting and optimisation for hotel revenue management. *Journal of Revenue and Pricing Management*, 6(3), 163-174.
- Chen, C.-C., Ruseski, J. E. & Schwartz, Z. (2009). Room rates as signals of quality, sell-out risk and the prospects of getting a better deal: analytical model and empirical evidence. *Tourism Economics*, 15 (2), 367-380.
- Chen, C. & Schwartz, Z. (2006). The importance of information asymmetry in customers' booking decisions: A cautionary tale from the Internet. *Cornell Hotel and Restaurant Administration Quarterly*, 47(3), 272-285.
- Chen, C. & Schwartz, Z. (2008a). Room rates patterns and customers' propensity to book hotel rooms. *Journal of Hospitality and Tourism Research*, 32(3), 287-306.
- Chen, C. & Schwartz, Z. (2008b). Timing matters: Travelers' advanced-booking expectations and decisions. *Journal of Travel Research*, 47(1), 35-42.
- Chen, C.-C. & Schwartz, Z. (2013). On revenue management and last minute booking dynamics. *International Journal of Contemporary Hospitality Management*, 25(1), 7-22.
- Chen, C., Schwartz, Z. & Vargas, P. (2011). The search for the best deal: How hotel cancellation policies affect the search and booking decisions of deal seeking customers. *International Journal of Hospitality Management*, 30(1), 129-135.
- Chiang, W.-C., Chen, J. C. H. & Xu, X. (2007). An overview of research on revenue management current issues and future research. *International Journal of Revenue Management*, 1(1), 97-127.
- Choi, S. (2006). Group revenue management: A model for evaluating group profitability. *Cornell Hotel and Restaurant Administration Quarterly*, 47(3), 260-271.
- Choi, S. & Kimes, S. E. (2002). Electronic distribution channels' effect on hotel revenue management. *Cornell Hotel and Restaurant Administration Quarterly*, 43(3), 23-31.
- Choi, S. & Mattila, A. S. (2003). Hotel revenue management and its impact on customers' perceptions of fairness. *Journal of Revenue and Pricing Management*, 2(4), 303-314.
- Choi, S. & Mattila, A. S. (2005). Impact of information on customer fairness perception of hotel revenue management. *Cornell Hotel and Restaurant Administration Quarterly*, 46(4), 444-451.
- Choi, S. & Mattila, A. S. (2006). The role of disclosure in variable hotel pricing: A cross-cultural comparison of customers' fairness perceptions. *Cornell Hotel and Restaurant Administration Quarterly*, 47(1), 27-35.
- Choi, T.Y. & Cho, V. (2000). Towards a knowledge discovery framework for yield management in the Hong Kong hotel industry. *International Journal of Hospitality Management*, 19(1), 17-31.
- Coleman, K. (2014). *Hotel business intelligence in action: Interpreting booking pace*. Hotelmarketing.com, 09<sup>th</sup> January. Available online at: [http://hotelmarketing.com/index.php/content/article/trends\\_that\\_could\\_shape\\_hotel\\_distribution\\_in\\_2014](http://hotelmarketing.com/index.php/content/article/trends_that_could_shape_hotel_distribution_in_2014) (Accessed on 09.01.2014).

- Collins, M. & Parsa, H. G. (2006). Pricing strategies to maximize revenues in the lodging industry. *International Journal of Hospitality Management*, 25(1), 91-107.
- Croes, R. & Semrad, K. (2012a). Does discounting work in the lodging industry? *Journal of Travel Research*, 51(5), 617-631.
- Croes, R. & Semrad, K. (2012b). Discounting works in the hotel industry: a structural approach to understanding why. *Tourism Economics*, 18(4), 769-779.
- Cross, R. (1997). *Revenue management: Hard-core tactics for market domination*. New York: Broadway.
- Cross, R., Higbie, J. & Cross, D. (2009). Revenue management's renaissance: a rebirth of the art and science of profitable revenue generation. *Cornell Hospitality Quarterly*, 50(1), 56-81.
- Das, S. P. (2007). *Microeconomics for business*. Thousand oaks, CA: Sage.
- Davidson, R. & Rogers, T. (2006). *Marketing destinations and venues for conferences, conventions and business events*. Oxford: Butterworth-Heinemann.
- Davis, B., Lockwood, A. & Stone, S. (2006). *Food and beverage management*. 3<sup>rd</sup> ed. Oxford: Butterworth-Heinemann.
- Demirciftci, T., Cobanoglu, C., Beldona, S. & Cummings, P. (2010). Room rate parity analysis across different hotel distribution channels in the U.S. *Journal of Hospitality Marketing & Management*, 19(4), 295-308
- Desiraju, R. & Shugan, S. M. (1999). Strategic service pricing and yield management. *Journal of Marketing*, 63(1), 44-56.
- Donaghy, K., McMahan-Beattie, U. & McDowell, D. (1997) Implementing yield management: lessons from the hotel sector. *International Journal of Contemporary Hospitality Management*, 9(2), 50-54.
- Dopson, L. R. & Hayes, D. K. (2009). *Managerial accounting for the hospitality industry*. Hoboken, NJ: John Wiley and Sons.
- El Gayar, N. F., Saleh, M., Atiya, A., El-Shishiny, H., Zakhary, A. A. Y. F. & Habib, H. A. A. M. (2011). An integrated framework for advanced hotel revenue management. *International Journal of Contemporary Hospitality Management*, 23(1), 84-98.
- El Haddad, R., Roper, A. & Jones, P. (2008). *The impact of revenue management decisions on customers attitudes and behaviours: A case study of a leading UK budget hotel chain*. EuroCHRIE 2008 Congress, Emirates Hotel School, Dubai, UAE, 11<sup>th</sup>-14<sup>th</sup> October. Available online at: <http://pc.parnu.ee/~htooman/EuroChrie/Welcome%20to%20EuroCHRIE%20Dubai%202008/papers/The%20Impact%20of%20Revenue%20Management.pdf> (Accessed on 06<sup>th</sup> April 2011).
- Emeksiz, M., Gursoy, D. & Icoz, O. (2006). A yield management model for five-star hotels: Computerized and non-computerized implementation. *International Journal of Hospitality Management*, 25(4), 536-551.
- Enz, C., Canina, L. & Lomanno, M. (2004). Why discounting does not work: The dynamics of rising occupancy and falling revenue among competitors. *Cornell Hospitality Report*, 4(7).
- Enz, C., Canina, L. & Liu, Z. (2008). Competitive dynamics and pricing behavior in US hotels: The role of co-location. *Scandinavian Journal of Hospitality and Tourism*, 8 (3), 230-250.
- Eslaminosratabadi, H. (2014). An investigation on green attitudes and demographics: Understanding the intention of international tourists in Malaysia to pay a premium for green hotels. *European Journal of Tourism Research*, 7, 92-108.



- Espinet, J.-M., Fluvia, M., Rigall-i-Torrent, R. & Saló (2012). Hotel characteristics and seasonality in prices: an analysis using Spanish tour operators' brochures. *Tourism Economics*, 18(4), 749-767.
- Frechtling, D. C. (2001) *Forecasting tourism demand: Methods and strategies*. Oxford: Butterworth-Heinemann.
- Gehrels, S. & Blunar, O. (2012). How economic crisis affects revenue management: the case of Prague Hilton hotels. *Research in Hospitality Management*, 2(1/2), 9-15.
- Gibson, C. H. (2012). *Financial reporting and analysis: Using financial accounting information*. Cengage Learning, 13<sup>th</sup> ed.
- Gilmore, H. J. & Pine, B. J. II (2002). Differentiating hospitality operations via experiences: Why selling services is not enough. *Cornell Hotel and Restaurant Administration Quarterly*, 43(3), 87-96.
- Goldman, P., Freling, R., Pak, K. & Piersma, N. (2002). Models and techniques for hotel revenue management using a rolling horizon. *Journal of Revenue & Pricing Management*, 1(3), 207-219.
- Guadix, J., Cortes, P., Onieva, L. & Munuzuri, J. (2010). Technology revenue management system for customer groups in hotels. *Journal of Business Research*, 63(5), 519-527.
- Guillet, B. D., Law, R. & Xiao, Q. (2013). Rate fences in hotel revenue management and their applications to Chinese leisure travellers: A fractional factorial design approach. *Cornell Hospitality Quarterly*, <http://cqx.sagepub.com/content/early/2013/11/27/1938965513507497>
- Hadjinicola, G. C. & Panayi, C. (1997). The overbooking problem in hotels with multiple tour-operators. *International Journal of Operations & Production Management*, 17(9), 874-885.
- Haensel, A. & Koole, G. (2011). Booking horizon forecasting with dynamic updating: A case study of hotel reservation data. *International Journal of Forecasting*, 27(3), 942-960.
- Hampton (2014). 100% Hampton guarantee. Available online at: <http://hamptoninn3.hilton.com/en/about/satisfaction.html> (Accessed on 23.01.2014).
- Hanks, R. D., Cross, R. G. & Noland, R. P. (2002). Discounting in the hotel industry. A new approach. *Cornell Hotel and Restaurant Administration Quarterly*, 43(4), 94-103.
- Harewood, S. I. (2006). Managing a hotel's perishable inventory using bid prices. *International Journal of Operations & Production Management*, 26(10), 1108-1122.
- Hayes, D. K. & Miller, A. A. (2011). *Revenue management for the hospitality industry*. Hoboken, N. J.: John Wiley & Sons.
- Hendler, R. & Hendler, F. (2004). Revenue management in fabulous Las Vegas: Combining customer relationship management and revenue management to maximise profitability. *Journal of Revenue and Pricing Management*, 3(1), 73-79.
- Heo, C. Y. (2013). Restaurant revenue management. In Legohérel, P., Poutier, E., & Fyall, A. (eds.). *Revenue management for hospitality and tourism*. Woodeaton, Oxford: Goodfellow Publishers Ltd., pp. 118-129.
- Heo, C. Y. & Lee, S. (2011). Influences of consumer characteristics on fairness perceptions of revenue management pricing in the hotel industry. *International Journal of Hospitality Management*, 30(2), 243-251.
- Heo, C. Y., Lee, S., Mattila, A., & Hu, C. (2013). Restaurant revenue management: Do perceived capacity scarcity and price differences matter? *International Journal of Hospitality Management*, 35, 316-326.

- Hampton Inn (2014). *100% Hampton guarantee*. Available online at: <http://hamptoninn3.hilton.com/en/about/satisfaction.html> (accessed on 23.02.2014).
- Herrmann, R. & Herrmann, O. (2014). Hotel room rates under the influence of a large event: The Oktoberfest in Munich 2012. *International Journal of Hospitality Management*, 39, 21-28.
- Hoogenboom, E. (2012). *The powerful tool for performance management, 'The GOPPAR Model' - a generous container of KPIs for hospitality*. Motus, Kamperland, The Netherlands. Available online at: <http://www.hospitalitynet.org/file/152004871.pdf> (Accessed on 18th April 2012).
- Hsu, C. H. C., Kang, S. K. & Wolfe, K. (2002). Psychographic and demographic profiles of niche market leisure travelers. *Journal of Hospitality and Tourism Research*, 26(1), 3-22.
- Hudson, S. (2008). *Tourism and hospitality marketing. A global perspective*. Thousand Oaks: Sage.
- Hung, W.-T., Shang, J.-K. & Wang, F.-C. (2010). Pricing determinants in the hotel industry: Quantile regression analysis. *International Journal of Hospitality Management*, 29(3), 378-384.
- Hwang, J. & Wen, L. (2009). The effect of perceived fairness toward hotel overbooking and compensation practices on customer loyalty. *International Journal of Contemporary Hospitality Management*, 21(6), 659-675.
- Intercontinental Hotel Group /IHG/ (2014). *IHG Rewards Club*. Available online at: [http://www.ihg.com/rewardsclub/us/en/enjoy-rewards#scmisc=wallet\\_enjoy-rewards\\_6c](http://www.ihg.com/rewardsclub/us/en/enjoy-rewards#scmisc=wallet_enjoy-rewards_6c) (Accessed on 23.02.2014).
- Illum, S. F., Ivanov, S. & Liang, Y. (2010). Using virtual communities in tourism research. *Tourism Management*, 31(3), 335-340.
- Ingold, A., McMahon-Beattie, U. & Yeoman, I. (eds.) (2001). *Yield management. Strategies for the service industries*. London: Continuum.
- Ismail, A. (2002) *Front office operations and management*. Albany, NY: Delmar.
- Ivanov, S. (2006). Management of overbookings in the hotel industry – basic concepts and practical challenges. *Tourism Today*, 6, 19-32.
- Ivanov, S. (2007a). Dynamic overbooking limits for guaranteed and nonguaranteed hotel reservations. *Tourism Today*, 7, 100-108.
- Ivanov, S. (2007b). Conceptualizing cannibalisation: the case of tourist companies. *Yearbook of International University College*, 3, 20-36. Available online at: <http://ssrn.com/abstract=1293730>
- Ivanov, S. (2008). Conceptual marketing framework for online hotel reservation system design. *Tourism Today* 8, 7-32. Available online at: <http://ssrn.com/abstract=1296040>
- Ivanov, S. (2013). Price discrimination as a hotel revenue management tool – from theory to practice. *Proceedings of the "Knowledge - traditions, innovations, perspectives" scientific conference*, Bourgas Free University, 14-15 June 2013, Bourgas, Bulgaria, Volume III, pp. 380-385. Available online at: <http://ssrn.com/abstract=2049341>
- Ivanov, S. (2014). Optimal overbooking limits for a 3-room type hotel with upgrade and downgrade constraints. *Tourism Economics* (forthcoming). Earlier version available at: <http://ssrn.com/abstract=2190042>
- Ivanov, S., Ivanova, M. & Iankova, K. (2012). *Sustainable tourism practices – mountain vs. non-mountain accommodation establishments in Bulgaria*. Paper presented at the International Conference "Changing Paradigms in Sustainable Mountain Tourism Research: Problems and

- Perspectives", Forum Brixen/Bressanone, Italy, 25<sup>th</sup>–28<sup>th</sup> October 2012. Available online at: <http://ssrn.com/abstract=2161586>
- Ivanov, S., & Zhechev, V. (2011). *Hotel marketing*. Varna: Zangador (in Bulgarian)
- Ivanov, S., & Zhechev, V. (2012). Hotel revenue management – a critical literature review. *Tourism*, 60(2), 175-197.
- Ivanova, M. & Ivanov, S. (2014). Hotel chains' entry mode in Bulgaria. *Anatolia* 25(1), 131-135.
- Iyengar, A. & Suri, K. (2012). Customer profitability analysis – An avant-garde approach to revenue optimisation in hotels. *International Journal of Revenue Management*, 6(1-2), 127-143.
- Jain, S. & Bowman, H. B. (2005). Measuring the gain attributable to revenue management. *Journal of Revenue and Pricing Management*, 4(1), 83-94.
- Kilby, J., Fox, J. & Lucas, A. F. (2005). *Casino operations management*. 2<sup>nd</sup> ed. Hoboken, NJ: John Wiley & Sons.
- Kim, W. G., Park, Y., Gazzoli, G. & Sheng, E. (2011). Benefit segmentation of international travelers to Macau, China. *Journal of Quality Assurance in Hospitality and Tourism*, 12(1), 28-57.
- Kimes, S. E. (1989). Yield management: a tool for capacity-constrained service firms. *Journal of Operations Management*, 8(4), 348–363.
- Kimes, S. E. (1999a). Group forecasting accuracy in hotels. *Journal of the Operational Research Society*, 50, 1104-1110.
- Kimes, S. E. (1999b). Implementing restaurant revenue management. A five step approach. *Cornell Hotel and Restaurant Administration Quarterly*, 40(3), 16-21.
- Kimes, S. E. (2000). Revenue management on the links: applying yield management to the golf-course industry. *Cornell Hotel and Restaurant Administration Quarterly*, 41(1), 120-127.
- Kimes, S. E. (2002). Perceived fairness of yield management. *Cornell Hotel and Restaurant Administration Quarterly*, 43(1), 21-30.
- Kimes, S. E. (2003). Revenue management: A retrospective. *Cornell Hotel and Restaurant Administration Quarterly*, 44(5/6), 131-138.
- Kimes, S. E. (2005). Restaurant revenue management: could it work? *Journal of Revenue & Pricing Management*, 4(1), 95-97.
- Kimes, S. E. (2009). Hotel revenue management in an economic downturn: Results of an international study. *Cornell Hospitality Report* 9(12).
- Kimes, S. E. (2011). The future of hotel revenue management. *Journal of Revenue and Pricing Management*, 10(1), 62-72.
- Kimes, S. E. & Chase, R. B. (1998). The strategic levers of yield management. *Journal of Service Research*, 1(2), 156-166.
- Kimes, S. E., Chase, R. B., Choi, S., Lee, P. Y. Y Ngonzi, E. N. (1998). Restaurant revenue management: applying yield management to the restaurant industry. *Cornell Hotel and Restaurant Administration Quarterly*, 39(3), 32-39.
- Kimes, S. E. & McGuire, K. A. (2001). Function-space revenue management: a case study from Singapore. *Cornell Hotel and Restaurant Administration Quarterly*, 42(6), 33-46.
- Kimes, S. E. & Robson, S. K. A. (2004). The impact of restaurant table characteristics on meal duration and spending. *Cornell Hotel and Restaurant Administration Quarterly*, 45(4), 333-346.

- Kimes, S. E. & Schruben, L. W. (2002). Golf course revenue management. A study of tee time intervals. *Journal of Revenue and Pricing Management*, 1(2), 111-120.
- Kimes, S. E. & Singh, S. (2009). Spa revenue management. *Cornell Hospitality Quarterly*, 50(1), 82-95.
- Kimes, S. E. & Thompson, G. M. (2004). Restaurant revenue management at Chevys: determining the best table mix. *Decision Sciences*, 35(3), 371-392.
- Kimes, S. E. & Thompson, G. M. (2005). An evaluation of heuristic methods for determining the best table mix in full-service restaurants. *Journal of Operations Management*, 23(6), 599-617.
- Kimes, S. E. & Wagner, P. E. (2001). Preserving your revenue-management system as a trade secret. *Cornell Hotel and Restaurant Administration Quarterly*, 42(5), 8-15.
- Kimes, S. E. & Wirtz, J. (2003). Has revenue management become acceptable? Findings from an international study on the perceived fairness of rate fences. *Journal of Service Research*, 6(2), 125-135.
- Koenig, M. & Meissner, J. (2010). List pricing versus dynamic pricing: Impact on the revenue risk. *European Journal of Operational Research*, 204(3), 505-512.
- Koide, T. & Ishii, H. (2005). The hotel yield management with two types of room prices, overbooking and cancellations. *International Journal of Production Economics*, 93-94, 417-428.
- Kotler, P., Armstrong, G. Saunders, J. & Wong V. (2002). *Principles of marketing*. Harlow: Prentice Hall, 3rd ed.
- Kotler, P., Bowen, J. & Makens, J. (2006). *Marketing for hospitality and tourism*. Harlow: Prentice Hall, 4<sup>th</sup> ed.
- Kotler, P., Keller, K. L., Brady, M., Goodmand, M., Hansen, T. (2009). *Marketing management*. Harlow, UK: Pearson.
- Koushik, D., Higbie, J. A. & Eister, C. (2012). Retail price optimization at intercontinental hotels group. *Interfaces*, 42(1), 45-57.
- Kozak, M. & Martin, D. (2012). Tourism life cycle and sustainability analysis: Profit-focused strategies for mature destinations. *Tourism Management*, 33(1), 188-194.
- Kuyumcu, A. H. (2002). Gaming twist in hotel revenue management. *Journal of Revenue and Pricing Management*, 1(2), 161-167.
- Lai, K.-K. & Ng, W.-L. (2005). A stochastic approach to hotel revenue optimization. *Computers & Operations Research*, 32(5), 1059-1072.
- Lan, Y., Ball, M & Karaesmen, I. Z. (2007). Overbooking and Fare-Class Allocation with Limited Information. *Robert H. Smith School of Business- Working Paper No. RHS-06-055*. Available at SSRN: <http://ssrn.com/abstract=1086239> (Accessed 10.12.2010).
- Las Vegas Convention and Visitors Authority /LVCVA/ (2013). *Historical Las Vegas Visitor Statistics (1970-2012)*. Available online at: <http://www.lvcva.com/includes/content/images/media/docs/Historical-1970-to-2012.pdf> (Accessed on 05.01.2014).
- Law, R. (2000). Back-propagation learning in improving the accuracy of neural network-based tourism demand forecasting. *Tourism Management*, 21(4), 331-340.
- Lee, S. K., Jang, S. (2012). Premium or discount in hotel room rates? the dual effects of a central downtown location. *Cornell Hospitality Quarterly*, 53(2), 165-173.

- Lee-Ross, D. & Johns, N. (1997). Yield management in hospitality SMEs. *International Journal of Contemporary Hospitality Management*, 9(2), 66–69.
- Legohérel, P., Poutier, E., & Fyall, A. (eds.) (2013a). *Revenue management for hospitality and tourism*. Woodeaton, Oxford: Goodfellow Publishers Ltd.
- Legohérel, P., Poutier, E., & Fyall, A. (2013b). The role of the revenue manager. In Legohérel, P., Poutier, E., & Fyall, A. (eds.). *Revenue management for hospitality and tourism*. Woodeaton, Oxford: Goodfellow Publishers Ltd., pp. 37-52.
- Legohérel, P., Poutier, E., & Fyall, A. (2013c). Setting up a revenue management system. In Legohérel, P., Poutier, E., & Fyall, A. (eds.). *Revenue management for hospitality and tourism*. Woodeaton, Oxford: Goodfellow Publishers Ltd., pp. 74-86
- Licata, J. W. & Tiger, A. W. (2010). Revenue management in the golf industry: Focus on throughput and consumer benefits. *Journal of Hospitality Marketing & Management*, 19(5), 480-502.
- Lieberman, W. H. (2011). Practical pricing for the hotel industry. In Yeoman, I. & McMahon-Beattie, U. (eds.) *Revenue Management. A Practical Pricing Perspective*. Palgrave Macmillan, 180-191.
- Lieberman, W. H. (2003). Getting the most from revenue management. *Journal of Revenue and Pricing Management*, 2(2), 103-115.
- Lim, C. & Chan, F. (2011). An econometric analysis of hotel–motel room nights in New Zealand with stochastic seasonality. *International Journal of Revenue Management*, 5(1), 63-83.
- Lim, C., Chang, C. & McAleer, M. (2009). Forecasting h(m)otel guest nights in New Zealand. *International Journal of Hospitality Management*, 28(2), 228-235.
- Liu, P. H., Smith, S., Orkin, E. B. & Carey, G. (2002). Estimating unconstrained hotel demand based on censored booking data. *Journal of Revenue and Pricing Management*, 1(2), 121-138.
- Liu, S., Lai, K. K., Dong, J. & Wang, S.-Y. (2006). A stochastic approach to hotel revenue management considering multiple-day stays. *International Journal of Information Technology & Decision Making*, 5(3), 545-556.
- Liu, S., Lai, K. K., Wang, S.-Y. (2008). Booking models for hotel revenue management considering multiple-day stays. *International Journal of Revenue Management*, 2(1), 78-91.
- Lockyer, T. (2007). Yield management: the case of the accommodation industry in New Zealand. *International Journal of Revenue Management*, 1(4), 315-326.
- Lovelock, C. & Wright, L. (1999). *Principles of service marketing and management*. Harlow: Prentice Hall.
- Lucas, R., Marinova, M. & Vodenska, M. (2009). From public to private: Has employment practice changed in Bulgarian hotels? *International Journal of Hospitality Management*, 28(3), 310-318
- Maier, T. A. (2011). Hospitality industry revenue management performance modelling: Uncovering issues associated with inconsistencies in price parity across multiple distribution channels in the US hotel market. *International Journal of Revenue Management*, 5(4), 290-307.
- Maier, T. A. (2012). International hotel revenue management. Web-performance effectiveness modelling – research comparative. *Journal of Hospitality and Tourism Technology*, 3(2), 121-137.
- Mainzer, B. W. (2004). Fast forward for hospitality revenue management. *Journal of Revenue and Pricing Management*, 3(3), 285-289.
- Marriott.com (2014). *Look No Further Best Rate Guarantee*. <http://www.marriott.com/hotel-prices/travel.mi> (Accessed on 23.02.2014).

- Mattila, A. S. & Choi, C. (2013). An analysis of consumers' reactions to travel websites' discrimination by computer platform. *Cornell Hospitality Quarterly*, <http://cqx.sagepub.com/content/early/2013/10/31/1938965513509879>
- Mauri, A. G. (2007). Yield management and perceptions of fairness in the hotel business. *International Review of Economics*, 54(2), 284-293.
- Mauri, A. G. (2012). *Hotel revenue management: Principles and practices*. Milan-Torino: Pearson Italia.
- McEvoy, B. J. (1997). Integrating operational and financial perspectives using yield management techniques: an add-on matrix model. *International Journal of Contemporary Hospitality Management*, 9(2), 60-65.
- Menezes, F. M. & Monteiro, P. K. (2005). *An introduction to auction theory*. Oxford: Oxford University Press.
- Milla, S. & Shoemaker, S. (2008). Three decades of revenue management: What's next? *Journal of Revenue and Pricing Management*, 7(1), 110-114.
- Modica, P. & Scanu, E. (2014). Day spa revenue management: some examples from Italy. In M. Smith & L. Puczko (Eds.) *Health, tourism and hospitality: wellness, spas and medical travel*. 2<sup>nd</sup> ed. Oxon: Routledge, pp. 269-273.
- Mohsin, A. (2008). How empowerment influences revenue management and service quality: the case of a New Zealand hotel. *International Journal of Revenue Management*, 2(1), 92-106.
- Montgomery, D. C., Jennings, C. L. & Kulachi, M. (2008). *Introduction to time series analysis and forecasting*. Hoboken, N.J.: John Wiley & Sons.
- Morales, D. R. & Wang, J. (2010). Forecasting cancellation rates for services booking revenue management using data mining. *European Journal of Operational Research*, 202(2), 554-562.
- Morrith, R. (2008). *Segmentation strategies for hospitality managers: Target marketing for competitive advantage*. Binghamton: The Haworth Press.
- Murphy, K., Semrad, K. & Yost, E. (2013). The impact of discounting room rates on in-house restaurant sales. *International Journal of Hospitality and Tourism Administration*, 14(1), 50-65.
- Myung, E., Li, L. & Bai, B. (2009). Managing the distribution channel relationship with e-wholesalers: Hotel operators' perspective. *Journal of Hospitality Marketing & Management*, 18(8), 811-828.
- Nagle, T. T. & Hogan, J. E. (2006). *The strategy and tactics of pricing. A guide to growing more profitably*. 4<sup>th</sup> ed. Upper Saddle River: Pearson Prentice Hall.
- Nash, J. C. & Nash, M. M. (2001). *Practical forecasting for managers*. London: Arnold.
- National Statistics Institute /NSI/ (2013a). *Arrivals of visitors from abroad to Bulgaria by months and by country of origin*. Available online at: [http://www.nsi.bg/sites/default/files/files/data/timeseries/TUR\\_1.4\\_For\\_en.xls](http://www.nsi.bg/sites/default/files/files/data/timeseries/TUR_1.4_For_en.xls) (Accessed on 05.01.2014).
- National Statistics Institute /NSI/ (2013b). *Accommodation establishments by statistical zones, statistical regions and by districts in 2013*. Available online at <http://www.nsi.bg/en/content/7067/annual-data> (Accessed on 03.03.2014).
- Neap, H. S. & Celik, T. (1999). Value of a product: A definition. *International Journal of Value-Based Management*, 12, 181-191.
- Netessine, S. & Shumsky, R. (2002). Introduction to the theory and practice of yield management. *INFORMS Transactions on Education*, 3(1), 34-44.



- Ng, I. C. L. (2009a). *The pricing and revenue management of services: A strategic approach*. London: Routledge.
- Ng, I. C. L. (2009b). A demand-based model for the advance and spot pricing of services. *Journal of Product & Brand Management*, 18(7), 517-528.
- Ng, I. C. L., Maull, R & Godsiff, P. (2008). An integrated approach towards revenue management. *Journal of Revenue and Pricing Management*, 7(2), 185-195.
- Noone, B.M. & Hultberg, T. (2011). Profiting through teamwork: The role of the revenue management and sales functions in group revenue management. *Cornell Hospitality Quarterly*, 52(4), 407-420.
- Noone, B. M., Kimes, S. E. & Renaghan, L. M. (2003). Integrating customer relationship management with revenue management: A hotel perspective. *Journal of Revenue and Pricing Management*, 2(1), 7-21.
- Noone, B. M., Lee, C. H. (2011). Hotel overbooking: The effect of overcompensation on customers' reactions to denied service. *Journal of Hospitality and Tourism Research*, 35(3), 334-357.
- Noone, B. M. & Mattila, A. S. (2009). Hotel revenue management and the Internet: The effect of price presentation strategies on customers' willingness to book. *International Journal of Hospitality Management*, 28(2), 272-279.
- Noone, B. M., McGuire, K. A. & Rohls, K. V. (2011). Social media meets hotel revenue management: Opportunities, issues and unanswered questions. *Journal of Revenue and Pricing Management*, 10(4), 293-305.
- Norman, E. D. & Mayer, K. J. (1997). Yield management in Las Vegas casino hotels. *Cornell Hotel and Restaurant Administration Quarterly*, 38(5), 28-33.
- Nowman, K. B. & van Dellen, S. (2012). Forecasting overseas visitors to the UK using continuous time and autoregressive fractional integrated moving average with discrete data. *Tourism Economics*, 18(4), 835-844.
- Oh, H., Fiore, A. M. & Jeoung, M. (2007). Measuring experience economy concepts: Tourism applications. *Journal of Travel Research* 46(2), 119-132.
- Okumus, F. (2004). Implementation of yield management practices in service organisations: empirical findings from a major hotel group. *The Service Industries Journal*, 24(6), 65-89.
- Onafowora, O. A. & Owoye, O. (2012). Modelling international tourism demand for the Caribbean. *Tourism Economics*, 18(1), 159-180.
- Orkin, E. (2003). The emerging role of function space optimisation in hotel revenue management. *Journal of Revenue and Pricing Management*, 2(2), 172-174.
- Padhi, S. S. & Aggarwal, V. (2011). Competitive revenue management for fixing quota and price of hotel commodities under uncertainty. *International Journal of Hospitality Management*, 30(3), 725-734.
- Palmer, A., Montaña, J. J. & Sesé, A. (2006). Designing an artificial neural network for forecasting tourism time series. *Tourism Management*, 27(5), 781-790.
- Palmer, D., Lunceford, S. & Patton, A. J. (2012). The engagement economy: How gamification is reshaping business. *Deloitte Review*, 11, 52-69
- Pan, B., Wu, D. C. & Song, H. (2012). Forecasting hotel room demand using search engine data. *Journal of Hospitality and Tourism Technology*, 3(3), 196-210.

- Patricio, L., Fisk, R. P., Falcão e Cunha, J. & Constantine, L. (2011). Multilevel service design: from customer value constellation to service experience blueprinting. *Journal of Service Research*, 14(2), 180-200.
- Peister, C. (2007). Table-games revenue management: applying survival analysis. *Cornell Hotel and Restaurant Administration Quarterly*, 48(1), 70-87.
- Pekgun, P., Menich, R. P., Acharya, S., Finch, P. G., Deschamps, F., Mallery, K., Van Sistine, J., Christianson, K. & Fuller, J. (2013). Carlson Rezidor hotel group maximizes revenue through improved demand management and price optimization. *Interfaces*, 43(1), 21-36.
- Peng, B., Song, H., Crouch, G. I. & Witt, S. F. (2014). A meta-analysis of international demand elasticities. *Journal of Travel Research*, doi: 10.1177/0047287514528283
- Phillips, R. (2005). *Pricing and revenue management optimization*. Palo Alto, CA: Stanford University Press.
- Phumchusri, N. & Mongkolkul, P. (2012). Hotel room demand forecasting via observed reservation information. In V. Kachitvichyanukul, H.T. Luong & R. Pitakaso (Eds). *Proceedings of the Asia Pacific Industrial Engineering & Management Systems Conference*, Patong Beach, Phuket, Thailand, pp. 1978-1985. Available online at: <http://www.apiems.net/conf2012/T5D5.pdf> (Accessed on 11.01.2014).
- Pine, B. J. II. & Gilmore, H. J. (1998). Welcome to the experience economy. *Harvard Business Review*, 76(4), 97-105.
- Pine, B. J. II. & Gilmore, H. J. (1999). *The experience economy: Work is theatre and every business a stage*. Boston, MA: Harvard Business School Press.
- Pine, B. J. II. & Gilmore, H. J. (2011). *The experience economy*. 2<sup>nd</sup> ed. Boston, MA: Harvard Business School Press;
- Plog, S. (2001). Why destinations rise and fall in popularity. An update of a Cornell Quarterly Classic. *Cornell Hotel and Restaurant Administration Quarterly*, 42(3), 13-24.
- Portolan, A. (2013). Impact of the attributes of private tourist accommodation facilities onto prices: A hedonic price approach. *European Journal of Tourism Research*, 6(1), 74-82.
- Pucciani, K. K. & Murphy, J. C. (2011). An investigation of data management and property management systems in hotels. *Tourism and Hospitality Management*, 17(1), 101-114.
- Pullman, M. & Rogers, S. (2010). Capacity management for hospitality and tourism: A review of current approaches. *International Journal of Hospitality Management*, 29(1), 177-187.
- Queenan, C. C., Ferguson, M. E., Higbie, J. & Kapoor, R. (2007). A comparison of unconstrained methods to improve revenue management systems. *Production and Operations Management*, 16(6), 729-746.
- Queenan, C. C., Ferguson, M. E. & Stratman, J. K. (2011). Revenue management performance drivers: An exploratory analysis within the hotel industry. *Journal of Revenue and Pricing Management*, 10(2), 172-188.
- Rajopadhye, M., Ghalia, M. B., Wang, P. P., Baker, T. & Eister, C. V. (2001). Forecasting uncertain hotel room demand. *Information Sciences*, 132(1-4), 1-11
- Rakadzhiska, S., Marinov, S. & Dyankov, T. (2013). *Tourism marketing*. Varna: University of Economics-Varna (in Bulgarian)



- Rannou, B. & Melli, D. (2003). Measuring the impact of revenue management. *Journal of Revenue and Pricing Management*, 2(3), 261-270.
- Rasekh, L. & Li, Y. (2011). Golf course revenue management. *Journal of Revenue and Pricing Management*, 10(2), 105-111.
- Rohlfs, K. V. & Kimes, S. E. (2007). Customers' perceptions of best available hotel rates. *Cornell Hotel and Restaurant Administration Quarterly*, 48(2), 151-162.
- Ropero, M. A. (2013). Effects of competition and quality on hotel pricing policies in an online travel agency. *Tourism Economics*, 19(1), 63-76.
- Rothstein, M. (1974). Hotel overbooking as a Markovian sequential decision process. *Decision Science*, 5(3), 389-404.
- Sanchez, J. F., & Satir, A. (2005). Hotel yield management using different reservation modes. *International Journal of Contemporary Hospitality Management*, 17(2), 136-146.
- Sarigollu, E. & Huang, R. (2005). Benefits segmentation of visitors to Latin America. *Journal of Travel Research*, 43(3), 277-293.
- Schütze, J. (2008). Pricing strategies for perishable products: the case of Vienna and the hotel reservation system hrs.com. *Central European Journal of Operations Research*, 16, 43-66.
- Schwartz, Z. (1998). The confusing side of yield management: Myths, errors, and misconceptions. *Journal of Hospitality & Tourism Research*, 22(4), 413-430.
- Schwartz, Z. (2000). Changes in hotel guests' willingness to pay as the date-of-stay draws closer. *Journal of Hospitality and Tourism Research*, 24(2), 180-198.
- Schwartz, Z. (2006). Advanced booking and revenue management: Room rates and the consumers' strategic zones. *International Journal of Hospitality Management*, 25(3), 447-462.
- Schwartz, Z. (2008). Time, price and advanced booking of hotel rooms. *International Journal of Hospitality and Tourism Administration*, 9(2), 128-146.
- Schwartz, Z. & Chen, C. (2010). The peculiar impact of higher room rates on customers' propensity to book. *International Journal of Contemporary Hospitality Management*, 22(1), 41-55.
- Schwartz, Z. & Chen, C.-C. (2012). Hedonic motivations and the effectiveness of risk perceptions-oriented revenue management policies. *Journal of Hospitality and Tourism Research*, 36(2), 232-250.
- Schwartz, Z., & Cohen, E. (2003). Hotel revenue management with group discount room rates. *Journal of Hospitality & Tourism Research*, 27(1), 24-47.
- Schwartz, Z. & Cohen, E. (2004). Hotel revenue management forecasting – evidence of expert-judgment bias. *Cornell Hotel and Restaurant Administration Quarterly*, 45(1), 85-98.
- Scott, N. & Parfitt, N. (2004). Lifestyle segmentation in tourism and leisure: imposing order or finding it? *Journal of Quality Assurance in Hospitality and Tourism*, 5(2/3/4), 121-139
- Selmi, N. & Dornier, R. (2011). Yield management in the French hotel business: An assessment of the importance of the human factor. *International Business Research*, 4(2), 58-66.
- Sheridan, M. F., Lee, S. & Roehl, W. (2013). Effects of hotel discounting practice on visitors' perceptions and visitation intentions. *Tourism Economics*, 19(3), 599-611.
- Shoemaker, S. (1994). Segmenting the U.S. travel market according to benefits realized. *Journal of Travel Research*, 32(3), 8-21.

- Shone, A. & Parry, B. (2004). *Successful event management. A practical handbook*. 2<sup>nd</sup> ed., London: Thomson Scientific.
- Shy, O. (2008). *How to price. A guide to pricing techniques and yield management*. Cambridge University Press.
- Skaalsvik, H. (2012). Why service recovery fails: A case study on the Norwegian Coastal Voyage (Hurtigruten). *European Journal of Tourism Research*, 5(2), 129-152.
- Song, H. & Li, G. (2008). Tourism demand modelling and forecasting – a review of recent research. *Tourism Management*, 29, 203-220.
- Song, H., Witt, S. F. & Li, G. (2009). *The advanced econometrics of tourism demand*. Oxon: Routledge.
- Steed, E. & Gu, Z. (2005). An examination of hotel room pricing methods: Practiced and proposed. *Journal of Revenue and Pricing Management*, 3(4), 369-379.
- Strategic Business Insights (2013). *US Framework and VALS™ Types*. Available online at: <http://www.strategicbusinessinsights.com/vals/ustypes.shtml> (Accessed on 29th December 2013).
- Swarbrooke, J. & Horner, S. (2001). *Business travel and tourism*. Oxford: Butterworth-Heinemann
- Talluri, K. T. & van Ryzin, G. (2005). *The theory and practice of revenue management*. New York: Springer Science+Business Media.
- Talon-Ballestrero, P., Gonzalez-Serrano, L., & Figueroa-Domecq (2014). A model for evaluating revenue management implementation (MERMI) in the hotel industry. *Journal of Revenue and Pricing Management (forthcoming)* doi: 10.1057/rpm.2013.47
- Taylor, W. & Kimes, S. E. (2011). The effect of brand class on perceived fairness of revenue management. *Journal of Revenue and Pricing Management*, 10(3), 271-284.
- Thompson, G. (2010). Restaurant profitability management: The evolution of restaurant revenue management. *Cornell Hospitality Quarterly*, 51(3), 308-322.
- Thompson, G. & Sohn, H. (2009). Time- and capacity-based measurement of restaurant revenue. *Cornell Hospitality Quarterly*, 50(4), 520-539.
- Toh, R. S. & de Kay, F. (2002). Hotel room inventory management: An overbooking model. *Cornell Hotel and Restaurant Quarterly*, 43(4), 79-90.
- Toilot, F. (2013). Staff empowerment and revenue management. In Legohérel, P., Poutier, E., & Fyall, A. (eds.). *Revenue management for hospitality and tourism*. Wood Eaton, Oxford: Goodfellow Publishers Ltd., pp. 213-222.
- Tranter, K. A., Stuart-Hill, T. & Parker, J. (2008). *Introduction to revenue management for the hospitality industry*. Harlow: Pearson Prentice Hall.
- Tribe, J. (2005). *The economics of recreation, leisure and tourism*. 3<sup>rd</sup> ed. Oxford: Elsevier.
- Tse, T. S. M. & Poon, Y. T. (2012). Revenue management: resolving a revenue optimization paradox. *International Journal of Contemporary Hospitality Management*, 24(4), 507-521.
- Varian, H. R. (2006). *Intermediate microeconomics: a modern approach*. 7<sup>th</sup> ed. New York: W. W. Norton & Co.
- Varini, K. & Burgess, C. (2010). Maximising profits: Do managers have the skills? *International Journal of Revenue Management*, 4(2), 163-178.
- Vergori, A. S. (2012). Forecasting tourism demand: the role of seasonality. *Tourism Economics*, 18(5), 915-930.

- Vinod, B. (2004). Unlocking the value of revenue management in the hotel industry. *Journal of Revenue and Pricing Management*, 3(2), 178-190.
- Voorhees, C. M., McCall, M. & Carroll, B. (2014). Assessing the benefits of the reward programs: A recommended approach and case study from the lodging industry. *Cornell Hospitality Report*, 14(1).
- Walsh, C. (2006). *Key management ratio*. Harlow: Financial Times Prentice Hall.
- Wang, X. L. (2013). Revenue management and customer relationship management. In Legohérel, P., Poutier, E., & Fyall, A. (eds.) *Revenue management for hospitality and tourism*. Woodeaton, Oxford: Goodfellow Publishers Ltd., pp. 194-212.
- Wang, X. L. (2012a). The impact of revenue management on hotel key account relationship development. *International Journal of Contemporary Hospitality Management*, 24(3), 358-380.
- Wang, X. L. (2012b). Relationship or revenue: Potential management conflicts between customer relationship management and hotel revenue management. *International Journal of Hospitality Management*, 31(3), 864-874.
- Wang, X. L. & Bowie, D. (2009). Revenue management: the impact on business-to-business relationships. *Journal of Services Marketing*, 23(1), 31-41.
- Wearne, N. & Morrison, A. (2011). *Hospitality marketing*. Oxon: Routledge.
- Weatherford, L. R., Kimes, S. E. & Scott, D. A. (2001). Forecasting for hotel revenue management: Testing aggregation against disaggregation. *Cornell Hotel and Restaurant Administration Quarterly*, 42(4), 53-64.
- Weatherford, L. R. & Kimes, S. E. (2003). A comparison of forecasting methods for hotel revenue management. *International Journal of Forecasting*, 19(3), 401-415.
- Weilbaker, D. C. & Crocker, K. (2001). The importance of selling abilities in corporate hospitality sales to corporate customers. *Journal of Hospitality & Leisure Marketing*, 7(4), 17-32.
- Werbach, K. & Hunter, D. (2012). *For the win: How game thinking can revolutionize your business*. Philadelphia: Wharton Digital Press.
- Wilson, A., Zeithaml, V., Bitner, M. J. & Gremler, D. (2012). *Service marketing: Integrating customer focus across the firm*. McGraw-Hill. 2<sup>nd</sup> European ed.
- Wirtz, J. & Kimes, S. E. (2007). The moderating effects of familiarity on the perceived fairness of revenue management pricing. *Journal of Service Research*, 9(3), 229-240.
- Wirtz, J., Kimes, S. E., Theng, J. H. & Patterson, P. (2003). Yield management: Resolving potential customer conflicts. *Journal of Revenue and Pricing Management* 2(3), 216-226.
- Woodruff, R. B. (1997). Customer value: the next source for competitive advantage. *Journal of the Academy of Marketing Science*, 25(2), 139-153.
- Wu, W.-Y., Hsiao, S.-W. & Tsai, C.-H. (2008). Forecasting and evaluating the tourist hotel industry performance in Taiwan based on Grey theory. *Tourism and Hospitality Research*, 8(2), 137-152.
- Yeoman, I. & McMahon-Beattie, U. (eds.) (2011). *Revenue Management. A Practical Pricing Perspective*. Palgrave Macmillan.
- Yeoman, I. & McMahon-Beattie, U. (eds.) (2004). *Revenue Management and Pricing: Case Studies and Applications*. Thomson Business Press.
- Yüksel, S. (2007). An integrated forecasting approach to hotel demand. *Mathematical and Computer Modelling*, 46(7-8), 1063-1070.

- Zakhary, A., Atiya, A. F., El-Shishiny, H., & El Gayar, N. E. (2011). Forecasting hotel arrivals and occupancy using Monte Carlo simulation. *Journal of Revenue & Pricing Management*, 10(4), 344-366.
- Zakhary, A., El Gayar, N. & Ahmed, S. E. H. (2010). Exploiting neural networks to enhance trend forecasting for hotels reservations. In Schwenker, F. & El Gayar, N. (eds.). *Artificial neural networks in pattern recognition*. 4th IAPR TC3 Workshop, ANNPR 2010, Cairo, Egypt, April 11-13, 2010, Proceedings. Berlin: Springer, 241-251.
- Zakhary, A., El Gayar & Atiya, A. F. (2008). A comparative study of the pickup method and its variations using a simulated hotel reservation data. *International Journal on Artificial Intelligence and Machine Learning*, 8, 15-21
- Zarraga-Oberty, C. & Bonache, J. (2007). Human factors in the design of revenue management systems in multinational corporations. *International Journal of Revenue Management*, 1(2), 141-153.
- Zhang, M. & Bell, P. C. (2010). Fencing in the context of revenue management. *International Journal of Revenue Management*, 4(1), 42-68.
- Zhang, M. & Bell, P. C. (2012). Price fencing in the practice of revenue management: An overview and taxonomy. *Journal of Revenue and Pricing Management*, 11(2), 146-159.
- Zhang, G. P. (2004). *Neural networks in business forecasting*. Hershey: Idea Group Publishing.
- Zhuang, W. & Li, M. Z. F. (2012). Dynamic pricing with two revenue streams. *Operations Research Letters*, 40(1), 46-51.
- Zikmund, W. G. & Babin, B. J. (2013). *Essentials of marketing research*. 5<sup>th</sup> ed. Mason: Cengage Learning.



Dr. Stanislav Ivanov is Associate Professor and Vice Rector for Academic Affairs and Research at International University College, Bulgaria. He is the Editor-in-Chief of the *European Journal of Tourism Research* (<http://ejtr.vumk.eu>) and serves on the Editorial boards of 20 other journals. His research interests include hotel marketing, revenue management, tourism economics, tourism and politics, special interest tourism. Dr. Ivanov's publications have appeared in top academic journals like *Annals of Tourism Research*, *Tourism Management*, *Tourism Economics*, *Journal of Heritage Tourism*, *Tourism Today*, *Tourism*, *Anatolia*, *Journal of Economic Studies*, *Journal of Southern Europe and the Balkans*, *South-Eastern Europe Journal of Economics*.



ISBN: 978-954-92786-3-7